

GENERAL INSTALLATION AND WIRING GUIDELINES



In This Chapter...

Safety Guidelines.....1-2

Introduction to the BRX Mechanical Design1-5

Dimensions and Installation.....1-6

Mounting Guidelines 1-10

Wiring Guidelines..... 1-15

I/O Module Wiring Options..... 1-24

System Wiring Strategies 1-26

Safety Guidelines



NOTE: Products with CE marks perform their required functions safely and adhere to relevant standards as specified by CE directives provided they are used according to their intended purpose and that the instructions in this manual are adhered to. The protection provided by the equipment may be impaired if this equipment is used in a manner not specified in this manual. A listing of our international affiliates is available on our Web site at <https://www.AutomationDirect.com>.



WARNING: Providing a safe operating environment for personnel and equipment is your responsibility and should be your primary goal during system planning and installation. Automation systems can fail and may result in situations that can cause serious injury to personnel or damage to equipment. Do not rely on the automation system alone to provide a safe operating environment. You should use external electromechanical devices, such as relays or limit switches, that are independent of the MPU application to provide protection for any part of the system that may cause personal injury or damage. Every automation application is different, so there may be special requirements for your particular application. Make sure you follow all national, state, and local government requirements for the proper installation and use of your equipment.

Plan for Safety

The best way to provide a safe operating environment is to make personnel and equipment safety part of the planning process. You should examine every aspect of the system to determine which areas are critical to operator or machine safety. If you are not familiar with PLC system installation practices, or your company does not have established installation guidelines, you should obtain additional information from the following sources.

- NEMA — The National Electrical Manufacturers Association, located in Washington, D.C., publishes many different documents that discuss standards for industrial control systems. You can order these publications directly from NEMA. Some of these include:
 - ICS 1, General Standards for Industrial Control and Systems
 - ICS 3, Industrial Systems
 - ICS 6, Enclosures for Industrial Control Systems
- NEC — The National Electrical Code provides regulations concerning the installation and use of various types of electrical equipment. Copies of the NEC Handbook can often be obtained from your local electrical equipment distributor or your local library.
- NFPA 70e — The National Fire Protection Associations document for electrical safety in workplaces. This can be obtained from the NFPA or other distributors and book stores.
- Local and State Agencies — many local governments and state governments have additional requirements above and beyond those described in the NEC Handbook. Check with your local Electrical Inspector or Fire Marshall office for information.

Three Levels of Protection



WARNING: The control program must not be the only form of protection for any problems that may result in a risk of personal injury or equipment damage.

The publications mentioned provide many ideas and requirements for system safety. At a minimum, you should follow these regulations. Also, you should use the following techniques, which provide three levels of system control.

1. Orderly system shutdown sequence in the MPU control program.
2. Mechanical disconnect for output module power.
3. Emergency stop switch for disconnecting system power.

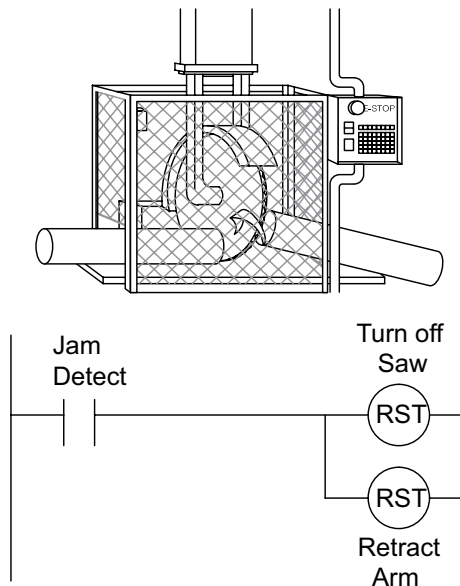

Orderly System Shutdown

The first level of fault detection is ideally the MPU control program in which you would identify any likely problems. Certain shutdown sequences should be performed. Some types of problems that are likely to occur are issues such as jammed parts or other process failures, that may not pose a risk of personal injury or equipment damage however, would need to be cleared prior to restarting the MPU control program.

System Power Disconnect

You should also use electromechanical devices, such as master control relays and/or limit switches, to prevent accidental equipment startup at an unexpected time. These safety devices should be installed in a manner that will prevent any machine operations from occurring where there maybe a possibility of injury to personnel or equipment.

For example, if the machine in the illustration above has a jammed part, the MPU control program can turn off the saw blade and retract the arbor. If the operator must open the guard to remove the part, you should also include a bypass switch that disconnects all system power any time the guard is opened.

Emergency Stop Circuits

Emergency stop (E-Stop) circuits are a critical part of automation safety. For each machine controlled by an MPU, provide an E-Stop device that is hardwired external to the MPU and easily accessed by the machine operator.

E-stop devices are commonly hardwired through a master control relay (MCR) or a safety control relay (SCR) that will isolate power from the MPU I/O system in an emergency.

MCRs and SCRs provide a convenient means for removing power from the I/O system during an emergency situation. By de-energizing an MCR (or SCR) coil, power to the input (optional) and output devices is removed. This event occurs when any emergency stop switch opens. However, the MPU continues to receive power and operate even though all its inputs and outputs are disabled.

The MCR circuit could be extended by placing an MPU fault relay (closed during normal MPU operation) in series with any other emergency stop conditions. This would cause the MCR circuit to drop the MPU I/O power in case of an MPU failure (memory error, I/O communications error, etc.).

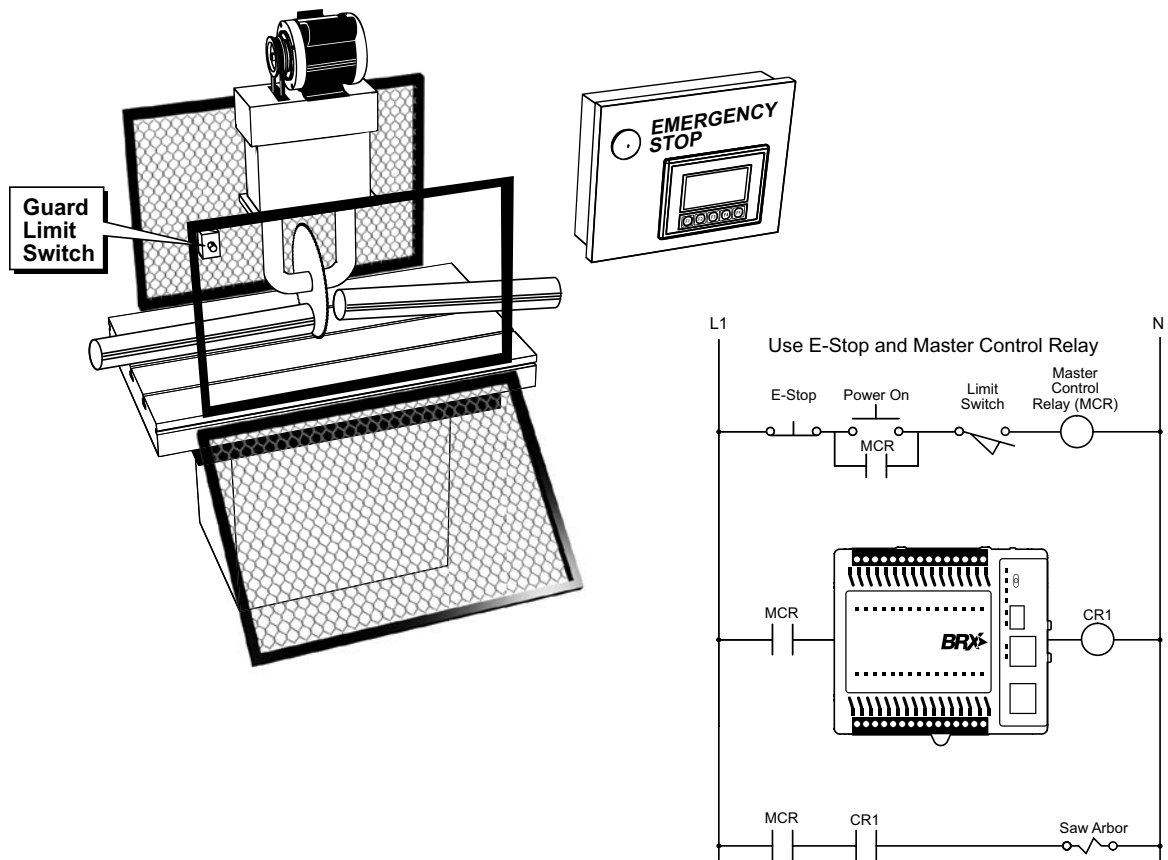

WARNING: For some applications, field device power may still be present on the terminal block even though the MPU is turned off. To minimize the risk of electrical shock, remove all field device power before you expose or remove MPU wiring.

Introduction to the BRX Mechanical Design

The BRX platform is designed to be used as a stand-alone controller or can be expanded. Using a combination of expansion modules, that simply snap on, you can create a sturdy and rugged PLC platform that can handle all your automation control applications.

Typical BRX Do-more! Platform System

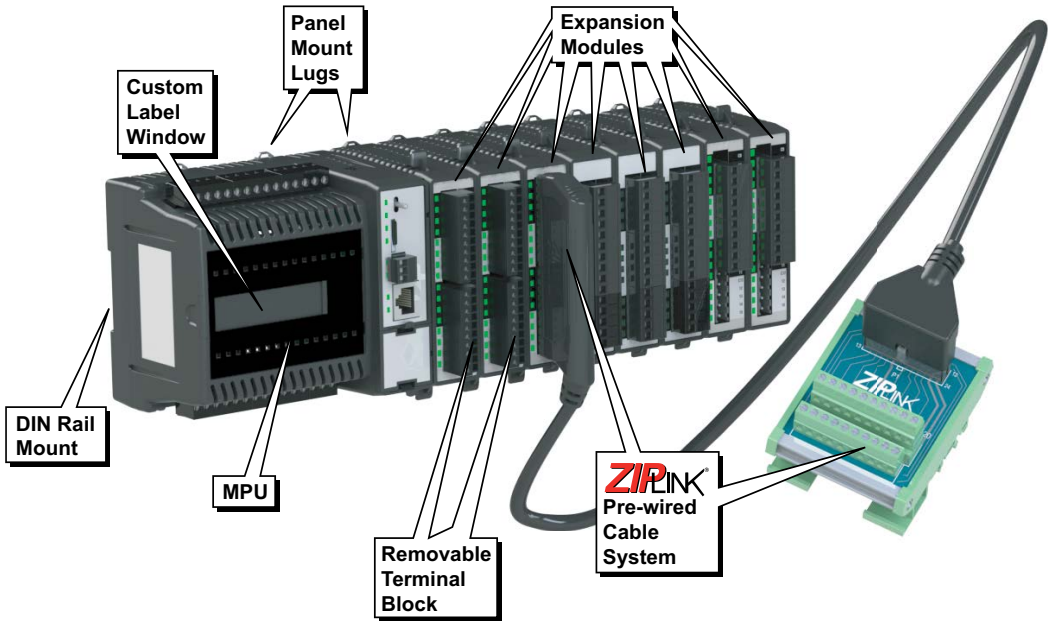

Dimensions and Installation

Before installing the BRX Micro PLC Unit (MPU) you will need to know the dimensions of the components considered. The diagrams on the following pages provide the nominal dimensions of each MPU series, Remote I/O and Expansion modules, which you can use when designing your enclosure. Remember to leave room for potential expansion to the right of the MPU or Remote I/O controller.

The height is the same for all components. The width varies depending on your choice of MPU and expansion modules. Allow adequate space to the right of MPU for mounting and dismounting additional Expansion modules. The BRX platform is designed to be mounted on standard 35mm DIN rail, or it can be surface mounted. Make sure you follow the installation guidelines for proper unit spacing.



NOTE: Downloadable Dimensional drawings for MPUs, Remote I/O controllers and Expansion modules are available at AutomationDirect.com.

BX ME MPU Dimensions, mm[inch]

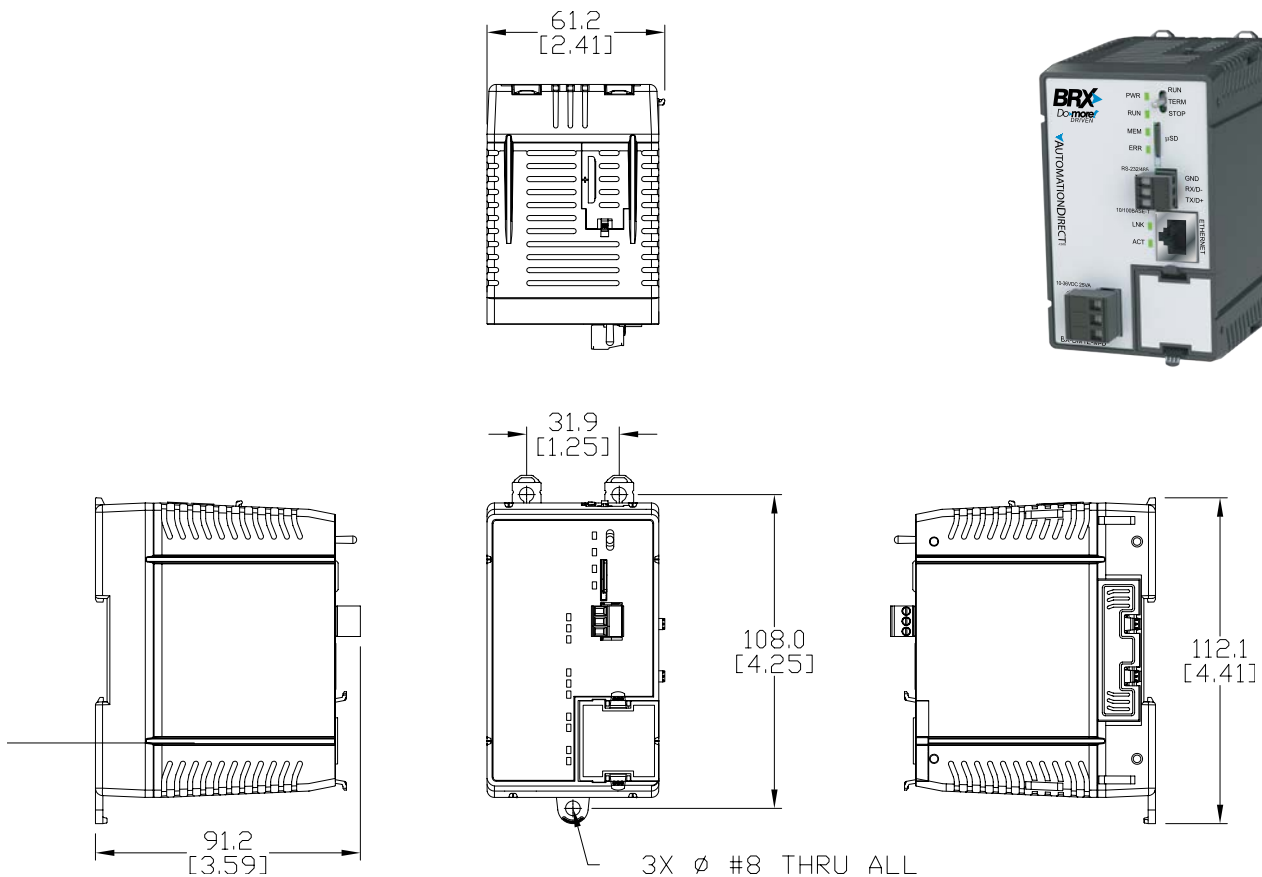

BX 10/10E MPU Dimensions, mm[inch]

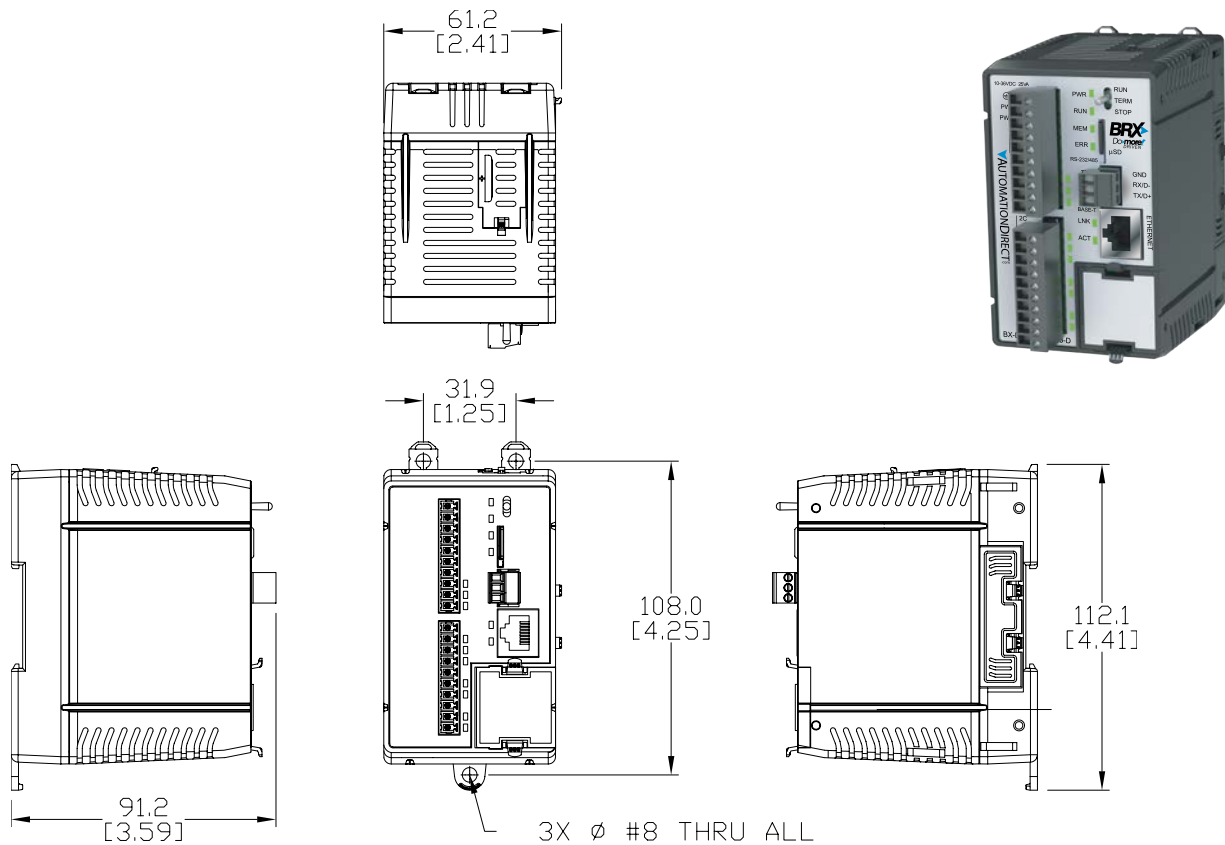

BX 18/18E MPU Dimensions, mm[inch]

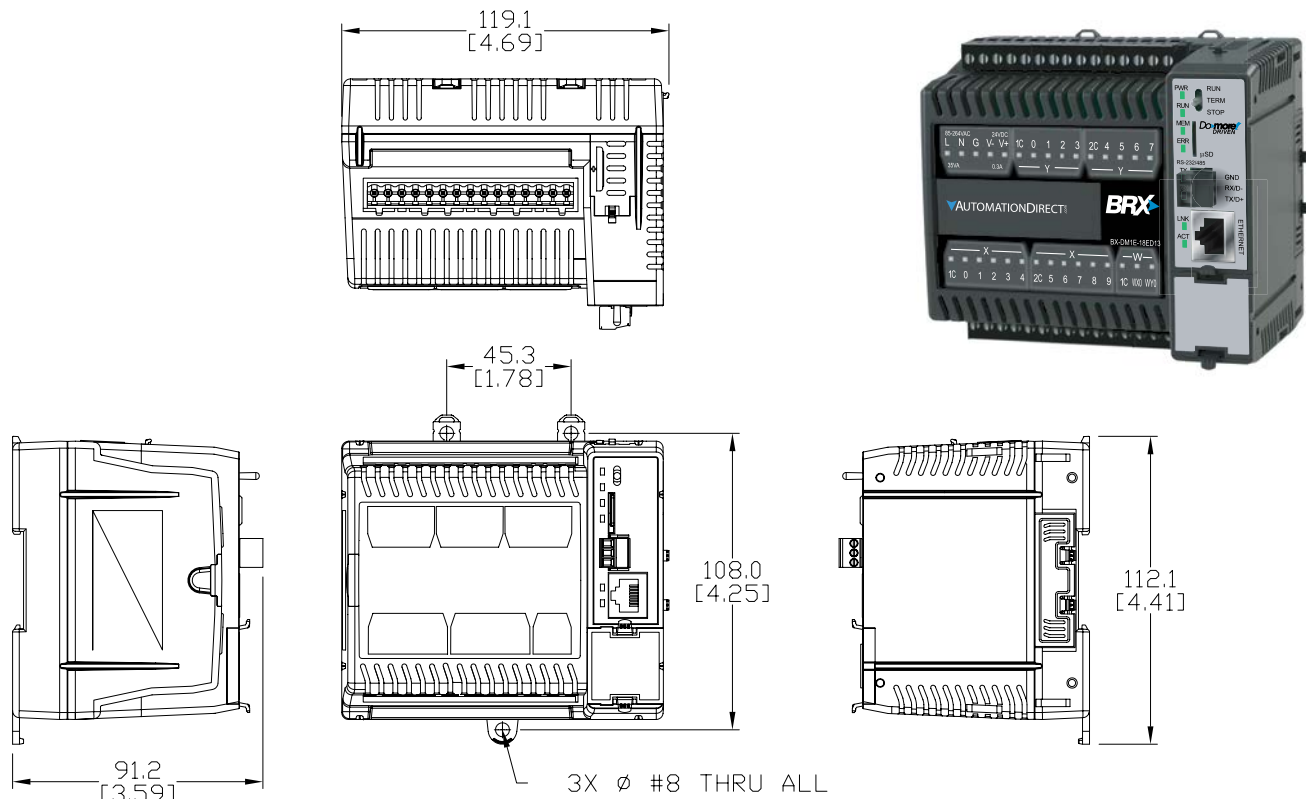

BX 36/36E Modules Dimensions, mm[inch]

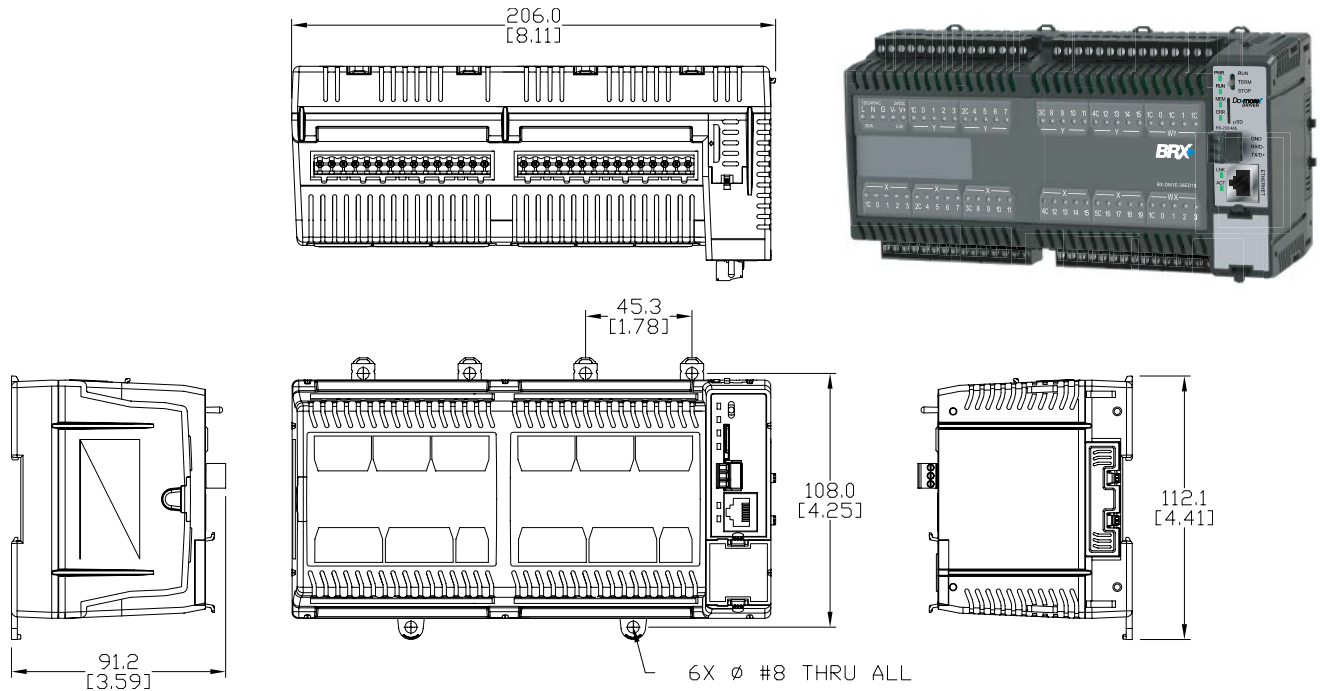

BRX Expansion Modules Dimensions, mm[inch]



NOTE: Allow a minimum of 45mm (1.75 in) to the right of MPU or Remote I/O chassis for mounting and dismounting Expansion modules.

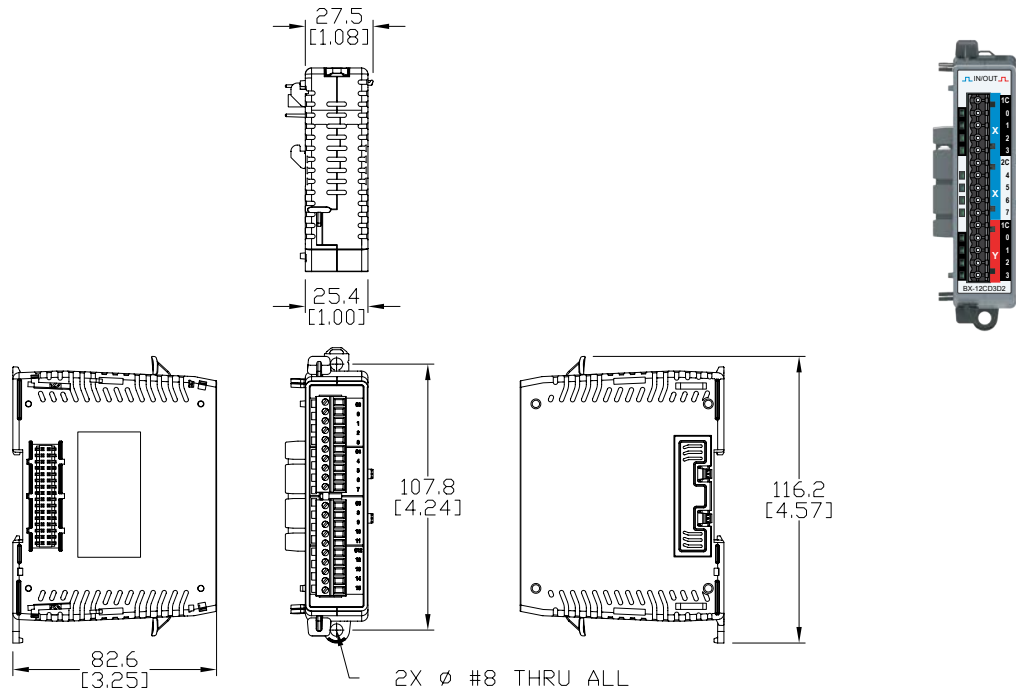

BX Remote I/O Controller Dimensions, mm[inch]

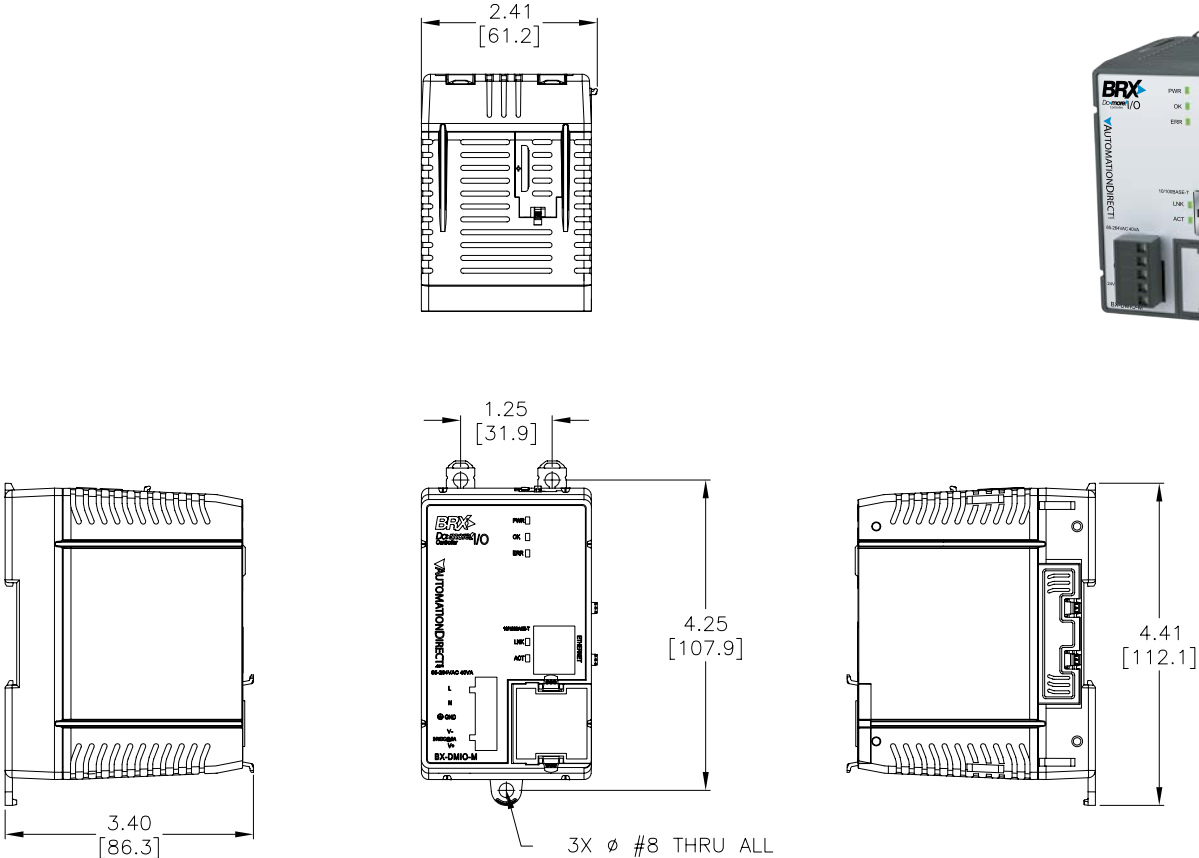

Mounting Guidelines

Enclosures

Your selection of a proper enclosure is important to ensure safe and proper operation of your BRX platform system. Applications for the BRX platform can vary and may require additional hardware considerations. The minimum considerations for enclosures include:

- Conformance to electrical standards
- Protection from the elements in an industrial environment
- Common ground reference
- Maintaining specified ambient temperature
- Access to the equipment
- Security or restricted access
- Sufficient space for proper installation and maintenance of the equipment

Mounting Position

Mount the BRX MPU horizontally, as shown in the illustration on the following page, to provide proper ventilation. Do not mount the BRX MPU vertically, upside down, or on a flat horizontal surface.

Mounting Clearances

Provide a minimum clearance of 2 inches (50mm) on all sides of the BRX MPU:

- Between the MPU and all sides of the enclosure.
- Between the MPU and enclosure door mounted operator panels and other door mounted items.
- Between the MPU and any wire duct.

Grounding

A good common ground reference (earth ground) is essential for proper operation of the BRX platform. One side of all control circuits, power circuits and the ground lead must be properly connected to earth ground by either installing a ground rod in close proximity to the enclosure or by connecting to the incoming power system ground. There must be a single-point ground (i.e. copper bus bar) for all devices in the enclosure that require an earth ground.



WARNING: The BRX System MUST have a proper earth ground. Do not operate the BRX MPU without proper earth grounding.

Temperature Considerations

The BRX platform should be installed in an operating environment that complies with the equipment temperature specifications (Please review Chapter 11 for information about environmental specifications). If the enclosure temperature has the potential to fluctuate above or below the specifications, cooling or heating the enclosure should be considered.

Power Considerations

The BRX platform units have a wide range of DC or AC power supply options. Some require a 12–24 VDC power supply where others are capable of using 120–240 VAC power supply. The BRX platform requires the use of EMF/RFI line noise filters on the AC power supply to achieve CE certification. Please review the European Union (CE) material in Appendix B for more information.

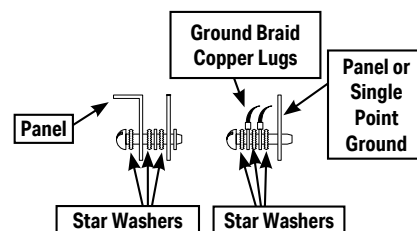
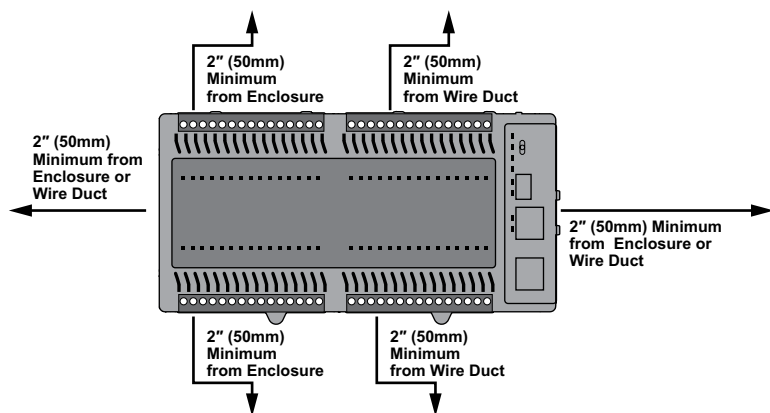
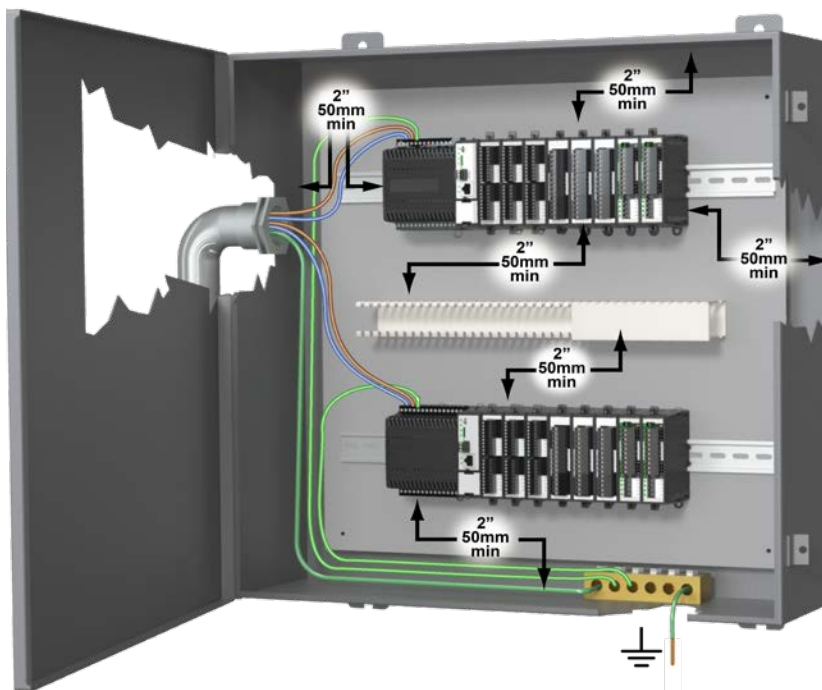

NOTE: Add 2" to mounting depth when using ZIPLink cable.



NOTE: Removable terminal block kits and ZIPLink wiring systems are sold separately. Detailed information is available in the BRX MPU Wiring chapters.



In addition to the panel layout guidelines, other specifications can affect the installation of an MPU. Always consider the following:

- Environmental Specifications
- Power Requirements
- Agency Approvals
- Enclosure Selection and Component Dimensions



WARNING: Do not disconnect equipment unless power has been switched off or the area is known to be non-hazardous. Observe all Arc Flash safety precautions when working on electrical components.

Agency Approvals

Some applications require agency approvals for particular components. The BRX platform agency approvals are listed below:

- UL (Underwriters' Laboratories, Inc.)
- CUL (Canadian Underwriters' Laboratories, Inc.)
- CE (European Economic Union)



NOTE: See the "EU Directives(CE)" in Appendix B in this manual for more information.

Using DIN Rail Mounts

The BRX platform can be secured to the cabinet using DIN rails. Use DIN rail that conforms to DIN EN standard 50022. We offer a complete line of DIN rail and DIN rail mounted apparatus. These rails are approximately 35mm high, with a depth of 7.5 mm. If you mount the BRX MPU on a rail, you should also consider using end brackets on each side. The end brackets keep the BRX MPU from sliding horizontally along the rail. This minimizes the possibility of accidentally pulling connecting circuit wiring loose.

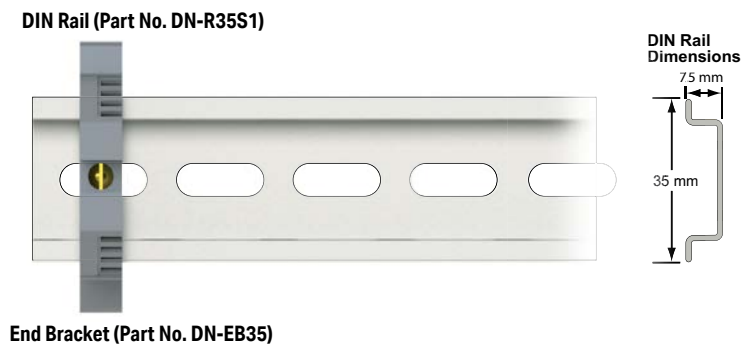

If you examine the bottom of the BRX MPU, you'll notice retaining clips. To secure to a DIN rail, hook the unit on to the DIN rail at the top of the mounting slot and gently press on the bottom of the unit until the unit snaps on to the DIN rail. The clips lock the BRX MPU onto the rail. To remove, pull down on the bottom retaining clips, slightly rotate the unit away from the DIN rail, lift the unit up off the DIN rail and pull it away from the rail.

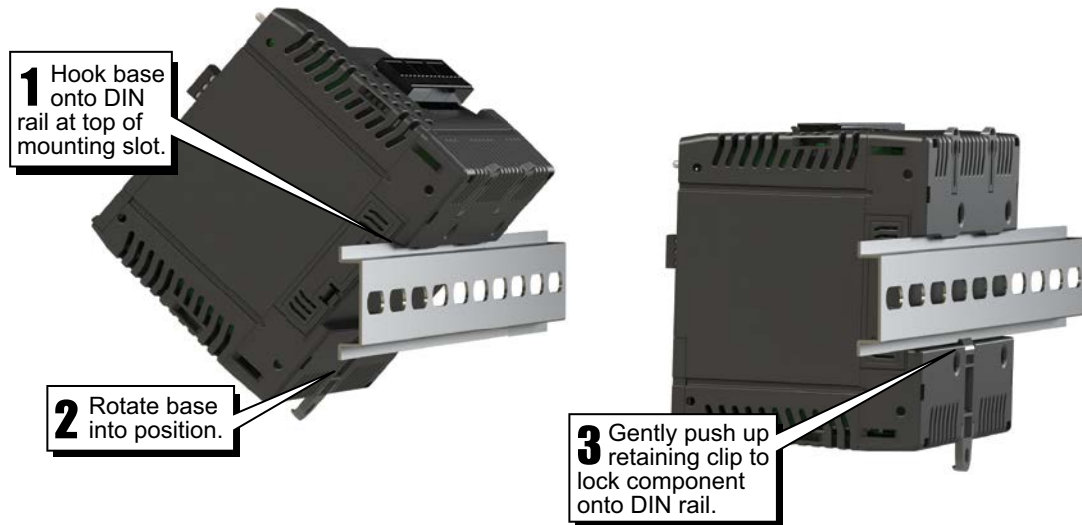

Direct Panel Mount

The BRX MPU can be surface mounted directly to a panel. Along the back, top and bottom, of the BRX MPU you will find tabs with holes. Pull these out revealing mounting holes through which to screw down the BRX MPU to a panel, without the need for a DIN rail.

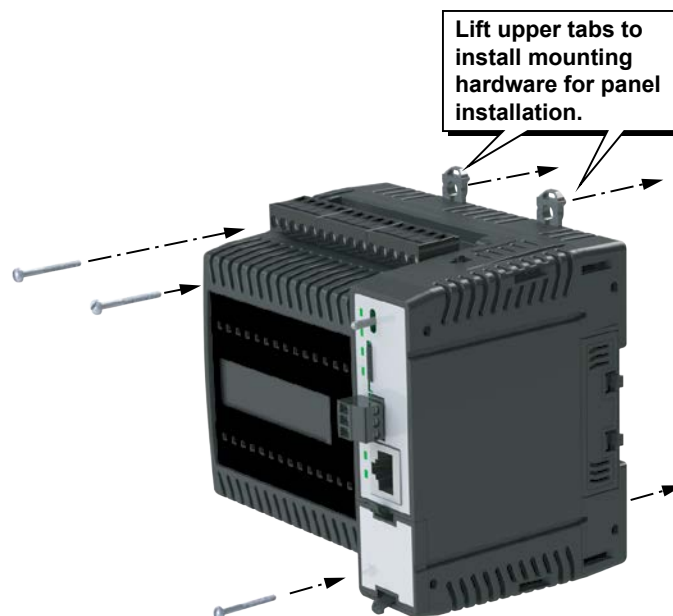

Installing the Expansion I/O Modules

You can add additional I/O points to the BRX MPU by installing expansion I/O modules. Information on how many expansion modules are supported is found in the chapter associated with each of the BRX MPUs.



NOTE: Allow a minimum of 45mm (1.75 in) to the right of MPU chassis or Expansion Modules for mounting and dismounting Expansion modules.

Expansion modules are installed to the right of the BRX MPU. Before installing the module, be sure the expansion connector cover is removed.

When adding Expansion modules to a DIN rail mounted BRX MPU, the Expansion Module must be mounted to the rail first then connected to the BRX MPU. To install the expansion module on DIN rail, place the module onto the top of the rail and gently push the bottom down and in towards the rail. The spring loaded retaining clips will snap into the rail keeping the module on the rail. Slide the module to the left until it locks into the BRX MPU.

To install the expansion module to a panel mounted BRX MPU, align the expansion module connector with the MPU expansion slot and insert into the BRX MPU until it locks into place. Pull out the top and bottom screw mount tabs and screw the expansion module into the panel.

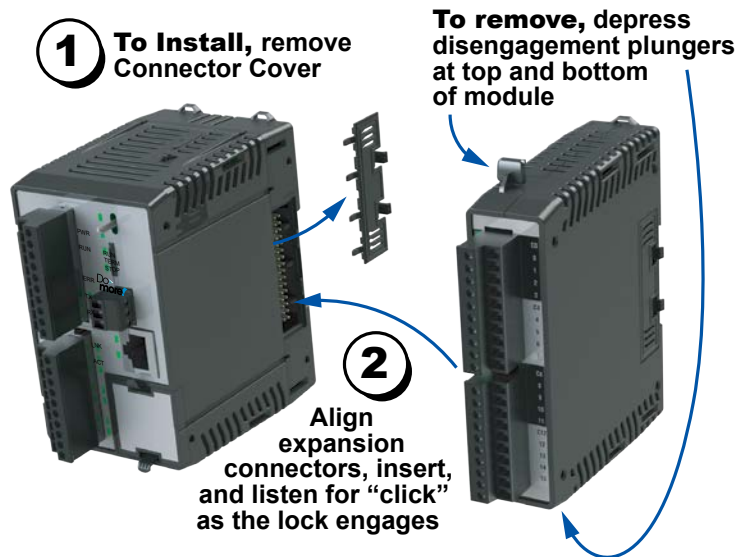

IMPORTANT!



Hot-Swapping Information

Note: This device cannot be Hot Swapped.

Wiring Guidelines

Power Wiring Connection

Connect the power source wiring for the BRX MPU as shown. Observe the precautions stated in this manual.

The power source for the BRX MPU's should be of good quality and sized appropriately so that the inrush when the PLC powers on does not cause a dip in the supplied voltage.

For DC-powered MPUs we recommend that the MPU be placed on a separate power supply. If this is not possible then care must be taken to reduce the CEMF component of coils and motors switching on and off by utilizing suppression techniques shown later in this chapter.

See the appropriate BRX MPU wiring chapter in this manual for technical specifications on wire size and screw torque recommendations on various terminal block connections available.



NOTE: *With external power supply off, terminal blocks may be removed for ease of wiring and then reinserted prior to applying power to the MPU.*

BX ME MPUs

Power Supply Connections



WARNING: Do not exceed the 24VDC auxiliary power supply load limit of 300mA.



WARNING: The BRX System **MUST** have a proper earth ground. Do not operate the BRX MPU without proper earth grounding.

AC Powered Units	
Part Number	External Power
BX-DM1E-M	120–240 VAC

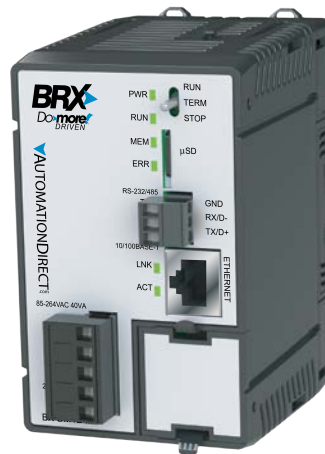
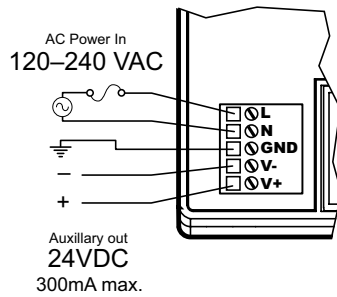

BX-DM1E-M
120–240 VAC

DC Powered Units	
Part Number	External Power
BX-DM1E-M-D	12–24 VDC

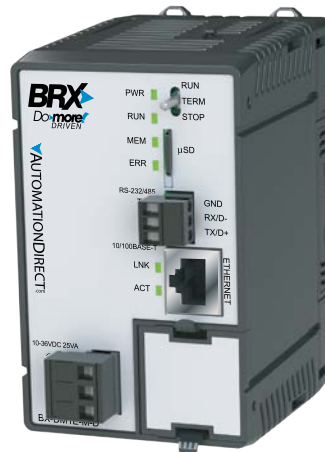
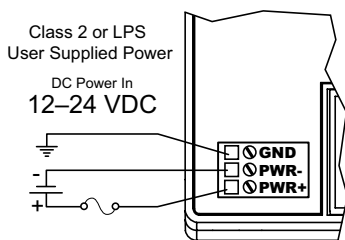

BX-DM1E-M-D
12–24 VDC

BRX 10/10E MPUs

Power Supply Connections

All BX 10/10E MPUs require 12–24 VDC external power supply. With power supply off, the terminal block may be removed for ease in wiring and then reinserted prior to applying power to the MPU. Follow the wiring termination diagram below for proper power supply connections.

DC Powered Units		
Part Number	External Power	
BX 10 MPUs		
BX-DM1-10ED1-D	12–24 VDC	
BX-DM1-10ED2-D		
BX-DM1-10ER-D		
BX-DM1-10AR-D		
BX 10E MPUs		
BX-DM1E-10ED13-D		
BX-DM1E-10ED23-D		
BX-DM1E-10ER3-D		
BX-DM1E-10AR3-D		

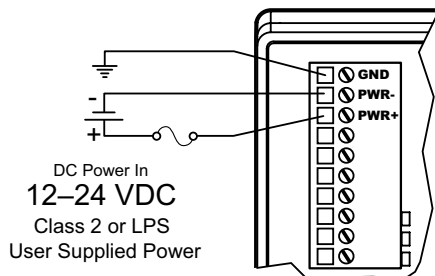

WARNING: The BRX System **MUST** have a proper earth ground. Do not operate the BRX MPU without proper earth grounding.

BX 18/18E MPUs

Power Supply Connections

AC Powered Units	
Part Number	External Power
BX 18 MPUs	
BX-DM1-18ED1	120–240 VAC
BX-DM1-18ED2	
BX-DM1-18ER	
BX-DM1-18AR	
BX-DM1-18AR	
BX 18E MPUs	
BX-DM1E-18ED13	120–240 VAC
BX-DM1E-18ED23	
BX-DM1E-18ER3	
BX-DM1E-18AR3	
BX-DM1E-18AR3	

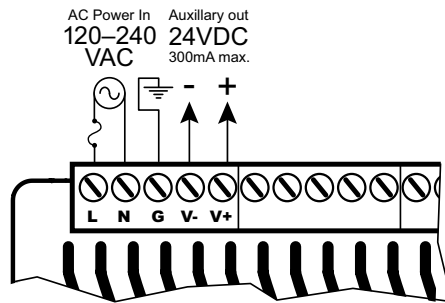

WARNING: Do not exceed the 24VDC auxiliary power supply load limit of 300mA.



WARNING: The BRX System **MUST** have a proper earth ground. Do not operate the BRX MPU without proper earth grounding.

BRX 18/18E MPUs, Continued

Power Supply Connections

DC Powered Units	
Part Number	External Power
BX 18 MPUs	
BX-DM1-18ED1-D	12–24 VDC
BX-DM1-18ED2-D	
BX-DM1-18ER-D	
BX 18E MPUs	
BX-DM1E-18ED13-D	12–24 VDC
BX-DM1E-18ED23-D	
BX-DM1E-18ER3-D	

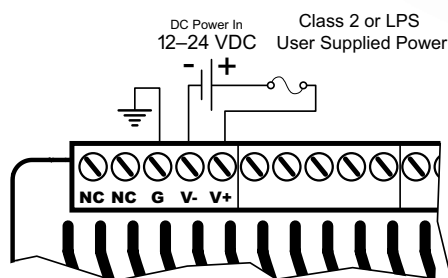

WARNING: No External AC power supply needed on this unit. The two terminals marked "NC" are not used. These terminals are not internally connected. **DO NOT CONNECT ANYTHING TO THESE TERMINALS!**



WARNING: The BRX System **MUST** have a proper earth ground. Do not operate the BRX MPU without proper earth grounding.

BX 36/36E MPUs

Power Supply Connections

AC Powered Units	
Part Number	External Power
BX 36 MPUs	
BX-DM1-36ED1	120–240 VAC
BX-DM1-36ED2	
BX-DM1-36ER	
BX-DM1-36AR	
BX 36E MPUs	
BX-DM1E-36ED13	120–240 VAC
BX-DM1E-36ED23	
BX-DM1E-36ER3	
BX-DM1E-36AR3	

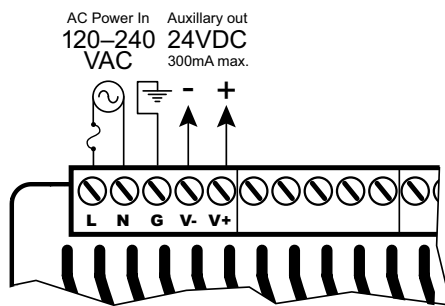

WARNING: Do not exceed the 24VDC auxiliary power supply load limit of 300mA.



WARNING: The BRX System **MUST** have a proper earth ground. Do not operate the BRX MPU without proper earth grounding.

BRX 36/36E MPUs, Continued

Power Supply Connections

DC Powered Units	
Part Number	External Power
BX 36 MPUs	
BX-DM1-36ED1-D	12–24 VDC
BX-DM1-36ED2-D	
BX-DM1-36ER-D	
BX 36E MPUs	
BX-DM1E-36ED13-D	12–24 VDC
BX-DM1E-36ED23-D	
BX-DM1E-36ER3-D	

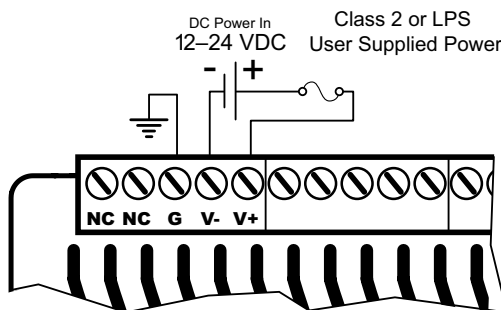

WARNING: No External AC power supply needed on this unit. The two terminals marked "NC" are not used. These terminals are not internally connected. **DO NOT CONNECT ANYTHING TO THESE TERMINALS!**



WARNING: The BRX System **MUST** have a proper earth ground. Do not operate the BRX MPU without proper earth grounding.

Isolation

Electrical noise can enter the system through the power source for the MPU and I/O. Installing an isolation transformer for all AC sources can correct this problem.

DC power sources should be properly grounded, except for Class II power supplies which should never be bonded to ground. Switching DC power supplies commonly generate more noise than linear supplies. Typically switching type supplies work well for analog circuits, but for some circuits where noise can be a factor, linear type supplies may be needed.

Analog wiring should be placed in separate wire ways or wiring bundles. Keep AC and DC wiring separated. Never run analog signal or communications wiring in parallel or in close proximity to high voltage wiring.

Transformers, inductors, VFDs, DC drives, welders, static generators, ultrasonic devices, radio transmitters, receivers, wiring and antennas, along with similar types of devices, generate large amounts of RF interference. DC wiring, analog wiring and communications wiring should be kept as far away from these sorts of devices and their associated input and output wiring as possible.

Devices that generate noise such as those listed above, along with coil driven devices such as relays, contactors, solenoids, etc., should be placed on a separate power supply from analog circuits. If this is not possible, then great care should be taken to properly suppress the transient voltage spikes from these devices turning on and off.

Grounding

A good common ground reference (earth ground) is essential for proper operation of the BRX MPU. Most noise problems result from improper grounding of the system. A good earth ground can be the single most effective way to correct noise problems. If a ground is not available, install a ground rod as close to the system as possible.

Ensure all ground wires are single point grounds and are not daisy chained from one device to another. Ground metal enclosures around the system. Loose ground wires on your devices are more susceptible to noise than the other wires in your system. A loose wire is no more than a large antenna waiting to introduce noise into the system; therefore, you should tighten all connections in your system.

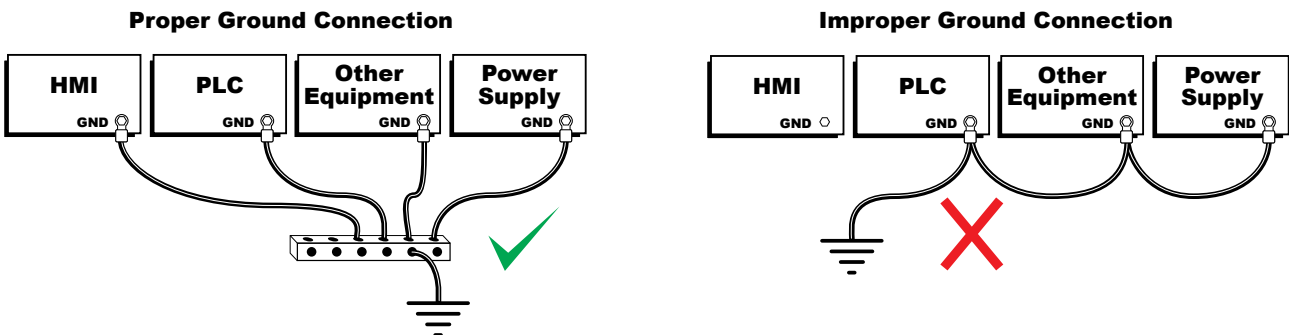

Cables with shields should be grounded on only one end of the shield. This prevents ground loops and allows for any radiated noise collected by the shield to properly drain to a single ground point.

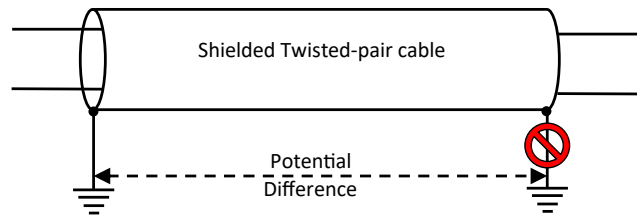

WARNING: The BRX System **MUST** have a proper earth ground. Do not operate the BRX MPU without proper earth grounding.

Fuse Protection

The BRX MPU and module I/O circuits do not have user serviceable internal fuses. In order to protect the MPU, we suggest you add external fuses to your I/O wiring. A fast-blow fuse with a lower current rating than the I/O bank common current rating can be wired to each common; or a fuse with a rating of slightly less than the maximum current per output point can be added to each output. Refer to the BRX MPU or module specifications for the model you are working with to find the maximum current per output point or per output common. Adding the external fuse does not guarantee the prevention of MPU or module damage, but it will provide added protection.

The image below shows a BRX platform MPU with Expansion Modules, where an external power supply is wired through a fused terminal block. Various other I/O is wired to DIN rail mounted fused terminal blocks.

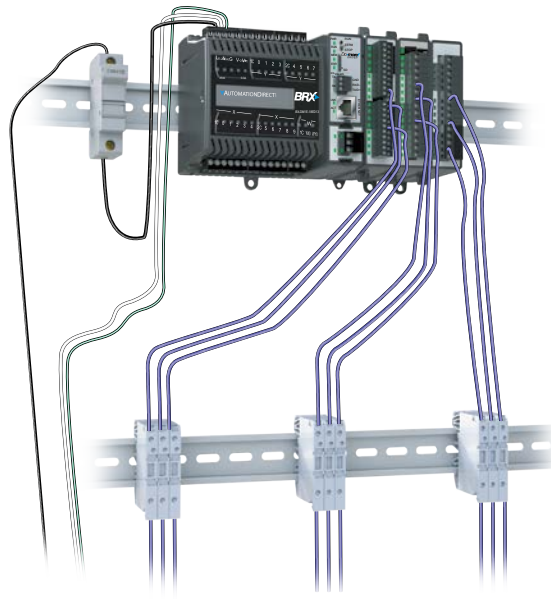

I/O Module Wiring Options

There are two available methods for wiring BRX MPUs and expansion modules: hand wiring to the optional removable terminal blocks or using the *ZIPLink* wiring system (recommended). Refer to the appropriate BRX chapter to review detailed information on the wiring options.



ZIPLink Wiring System



ZIPLink Pre-Wired Cable



ZIPLink Remote Feedthrough Terminal Block Module

Planning the I/O Wiring Routes

The following guidelines provide general information on how to wire the I/O connections to the BRX platform. For specific information on wiring a particular component of the BRX platform, refer to the wiring specifications in Chapters 2 through 5 for BRX MPUs and Chapter 7 for I/O expansion modules.

1. If using removable terminal blocks or *ZIP*Link connector blocks, follow the wire size given for the connection method.
2. Always use a continuous length of wire from BRX MPU to I/O connections or junction panel terminations. Do not splice wires to attain a needed length.
3. Use the shortest run possible between devices.
4. Use conduit or wire trays for routing where possible.
5. Avoid running low voltage control or communication wiring near high voltage wiring.
6. Avoid confusion by separating input wiring runs from output wiring runs where possible.
7. To minimize voltage drops when wires must run long distances, consider using multiple wires for the return line.
8. Avoid running DC wiring in close proximity to AC wiring where possible.
9. Avoid creating sharp bends in wire runs; follow accepted Electrical Code standards.
10. Route communications wiring separately from control and power wiring.

Auxiliary DC Power Supply

On AC powered BRX MPUs an integral auxiliary isolated 24VDC power supply with its own isolation boundary is included. Since this is isolated it can be used to power input and/or output circuits.

In some cases using the built-in auxiliary 24VDC supply can result in a cost savings for your control system precluding the purchase of an addition external DC power source. It can power combined loads up to 300mA. Be careful not to exceed the current rating of the supply. As a system designer, you may be able to design or select field devices which can take advantage of the 24VDC auxiliary supply.



WARNING: Do not exceed the 24VDC auxiliary power supply load limit of 300mA.

System Wiring Strategies

The BRX platform is very flexible and will work in many different wiring configurations. By studying this section before actual installation, you can find the best wiring strategy for your application. This will help to lower system cost and wiring errors, while avoiding potential safety problems.

MPU Isolation Boundaries

MPU circuitry is divided into three main regions separated by isolation boundaries, shown in the drawing below. Electrical isolation provides safety, such that a fault in one area does not damage another. The transformer in the power supply provides magnetic isolation between the primary and secondary sides. Optical isolators provide isolation in Input and Output circuits. This isolates logic circuitry from the field side I/O. The discrete inputs are isolated from the discrete outputs because each is isolated from the logic side. Isolation boundaries protect the devices which are connected to the communication ports, such as PCs and HMIs, from power input faults or field wiring faults. When wiring a BRX MPU, it is extremely important to avoid making external connections that connect logic side circuits to any other.

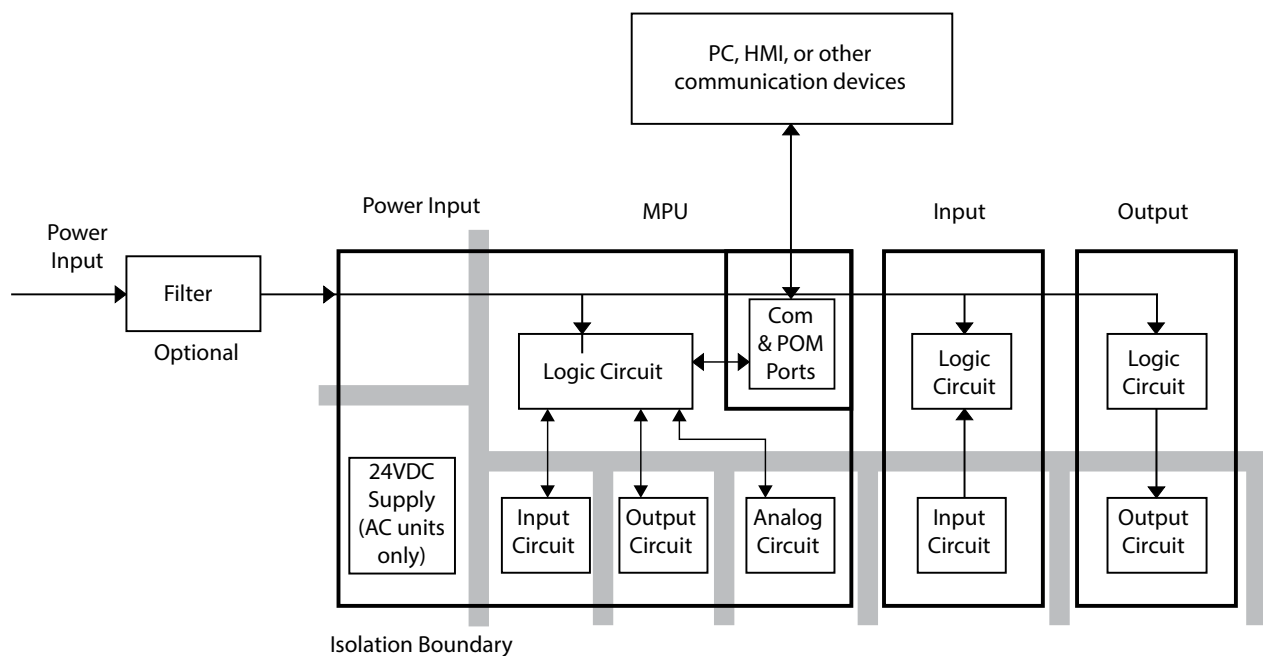

Logical Representation of Isolation Boundaries

Sinking/Sourcing Concepts

Before wiring field devices to the BRX MPU I/O, it's necessary to have a basic understanding of “sinking” and “sourcing” concepts. Use of these terms occurs frequently in input or output circuit discussions. The purpose of this section is to explain the terms. The short definitions are as follows:

Sinking = Path to supply ground (–) or switching ground

Sourcing = Path to supply source (+) or switching +V

These terms only apply to DC circuits, not AC circuits. Input and output points that are either sinking or sourcing can conduct current in only one direction. This means it is possible to wire the external supply and field device to the I/O point with current trying to flow in the wrong direction, in which case the circuit will not operate.

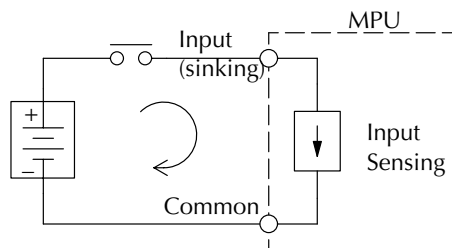

The diagram above shows a “sinking” MPU input. To properly connect the external supply, connect it so that the input provides a path to ground (–). Start at the MPU input terminal, follow through the input sensing circuit, exit at the common terminal, and connect the supply (–) to the common terminal.

The switch between the supply (+) and the input completes the circuit. Current flows in the direction of the arrow when the switch is closed. By applying the circuit principle above to the four possible combinations of input/output sinking/sourcing types, we have the four circuits as shown below.

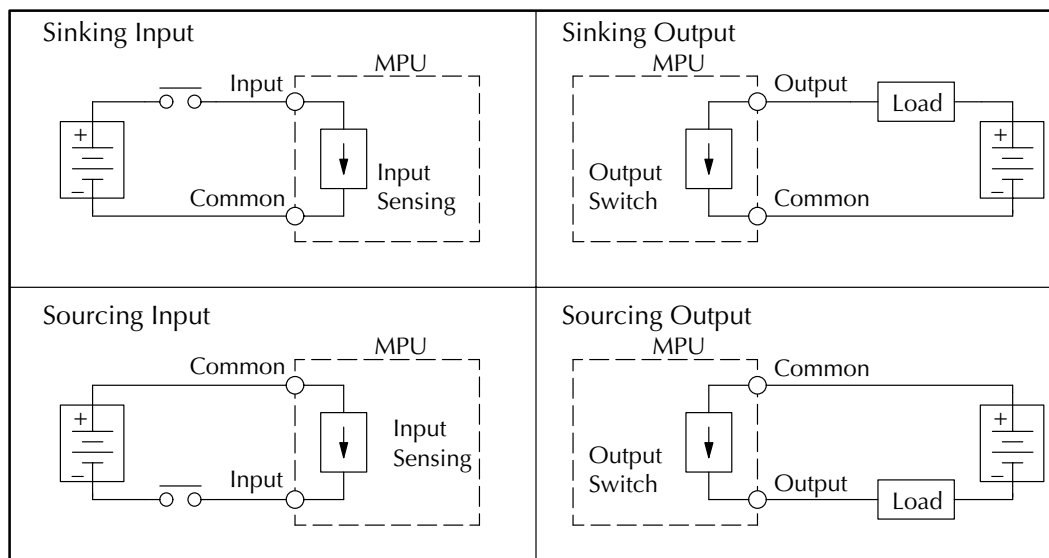

I/O “Common Terminal” Concepts

In order for a BRX MPU I/O circuit to operate, current must enter at one terminal and exit at another. This means at least two terminals are associated with every I/O point. In the figure below, the input or output terminal is the main path for the current. One additional terminal must provide the return path to the power supply.

If there was unlimited space then every I/O point could have two dedicated terminals as the figure below shows. Providing this level of flexibility is not practical or necessary for most applications.

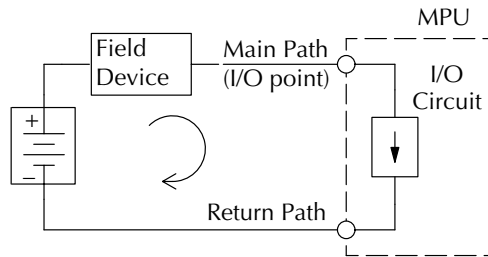

Most I/O point groups share the return path (common) among two or more I/O points. The figure below shows a group (or bank) of four input points which share a common return path. In this way, the four inputs require only five terminals instead of eight.

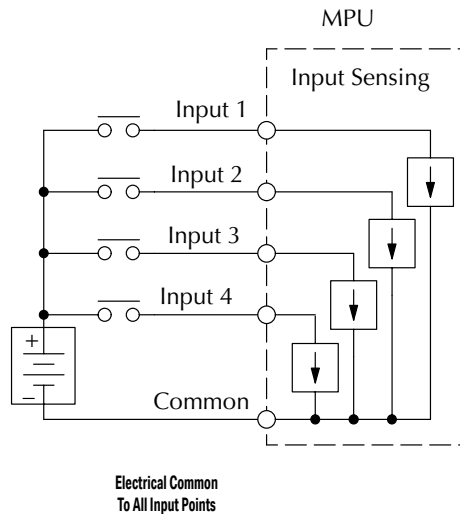

NOTE: In the circuit above, the current in the common path is equal to the sum of the energized channels. This is especially important in output circuits, where larger gauge wire is sometimes needed for the commons.

DC Input Wiring Methods

DC inputs can be wired as either sinking or sourcing inputs. The dual diodes (shown in this diagram) allow current to flow in either direction. Inputs grouped by a common point must be either all sinking or all sourcing. DC inputs typically operate in the range of 12–24 VDC.

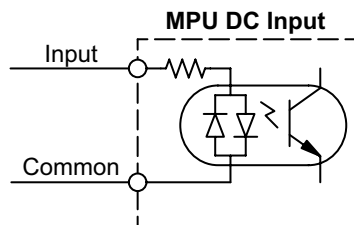

Sinking Input Sensor (NPN Type) to BRX MPU Sourcing Input

In the following example, a field device has an open-collector NPN transistor output. When energized, it sinks current to ground from the DC input point. The input current is sourced from the common terminal connected to power supply (+).

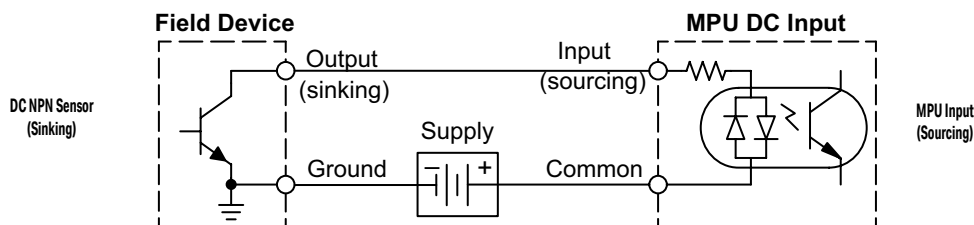

Sourcing Input Sensor (PNP Type) to BRX MPU Sinking Input

In the following example, a field device has an open-emitter PNP transistor output. When energized, it sources current to the input point, which sinks the current to ground. Since the field device loop is sourcing current, no additional power supply is required for the module.

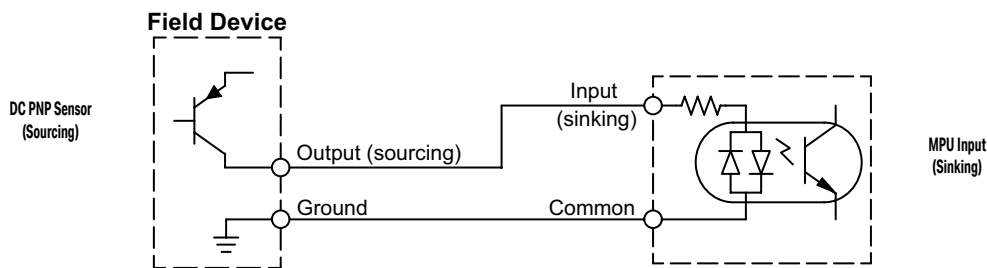

DC Output Wiring Methods

DC output circuits are wired as all current sinking or all current sourcing depending on which output module part number is used. DC outputs typically operate in the range of 12–24 VDC.

MPU Sinking Output to Sourcing Load Device

Many applications require connecting a MPU output point to a DC input on a field device load. This type of connection is made to carry a low-level DC signal.

In the following example, the MPU output point sinks current to ground (common) when energized. The output is connected to a field device load with a sourcing input.

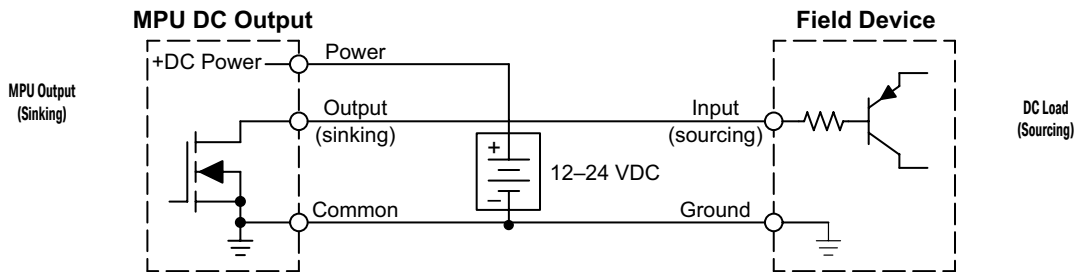

MPUs DC Sinking Output to Sinking Load Device

In the example below, a sinking output point is connected to the sinking input of a field device load. In this case, both the MPU output and field device input are sinking type. Since the circuit must have one sourcing and one sinking device, we add sourcing capability to the MPU output by using a pull-up resistor. In the circuit below, we connect $R_{\text{pull-up}}$ from the output to the DC output circuit power input.

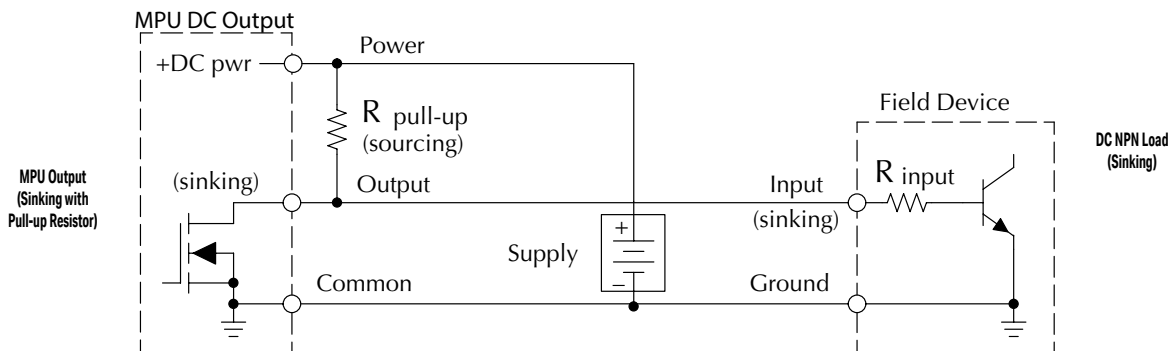

NOTE: DO NOT attempt to drive a heavy load (>25mA) with this pull-up method.



NOTE: Using the pull-up resistor to implement a sourcing output has the effect of inverting the output point logic. In other words, the field device input is energized when the MPU output is OFF, from a ladder logic point-of-view. Your ladder program must take this into consideration and generate an inverted output. Or, you may choose to cancel the effect of the inversion elsewhere, such as in the field device.

It is important to choose the correct value of $R_{\text{pull-up}}$. In order to do so, we need to know the nominal input current to the field device (I_{input}) when the input is energized. If this value is not known, it can be calculated as shown (a typical value is 15mA). Then use I_{input} and the voltage of the external supply to compute $R_{\text{pull-up}}$. Then calculate the power $P_{\text{pull-up}}$ (in watts), in order to size $R_{\text{pull-up}}$ properly.

$$I_{\text{input}} = \frac{V_{\text{input (turn-on)}}}{R_{\text{input}}}$$

$$R_{\text{pull-up}} = \frac{V_{\text{supply}} - 0.7}{I_{\text{input}}} - R_{\text{input}}$$

$$P_{\text{pull-up}} = \frac{V_{\text{supply}}^2}{R_{\text{pull-up}}}$$

Relay Outputs - Wiring Methods

Relays are best for the following applications:

- Loads that require higher currents than the solid-state outputs can deliver
- Cost-sensitive applications
- Some output channels need isolation from other outputs (such as when some loads require different voltages than other loads)

Relay outputs are available in two contact arrangements. Form A type, or SPST (single pole, single throw) type. They are normally open and are the simplest to use. The Form C, or SPDT (single pole, double throw) type has a center contact which moves and a stationary contact on either side. This provides a normally closed contact and a normally open contact.

Relay with Form A contacts

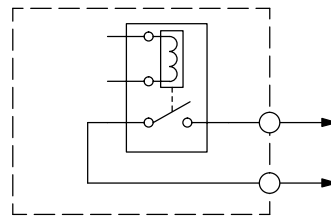

The relays in some relay output modules share common terminals, which connect to the wiper contact in each relay of the bank. Other relay modules have relays which are completely isolated from each other. In all cases, the module drives the relay coil when the corresponding output point is on.

Relay with Form C contacts

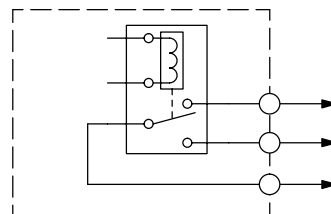

Some applications where relays would NOT be used:

- Loads that require currents under 10mA
- Loads which must be switched at high speed or heavy duty cycle.

Relay Outputs – Transient Suppression for Inductive Loads in a Control System

The following pages are intended to give a quick overview of the negative effects of transient voltages on a control system and provide some simple advice on how to effectively minimize them (Transient Voltage Suppression or TVS). The need for transient voltage suppression is often not apparent to the newcomers in the automation world. Many mysterious errors that can afflict an installation can be traced back to a lack of transient suppression.

What is a Transient Voltage and Why is it Bad?

Inductive loads (devices with a coil) generate transient voltages as they transition from being energized to being de-energized. If not suppressed, the transient can be many times greater than the voltage applied to the coil. These transient voltages can damage the BRX MPU outputs or other sensitive electronic devices connected to the circuit, and cause unreliable operation of adjacent electronics. Transients must be managed with suppressors (TVS) for longer component life while sustaining reliable operation of the control system.

Examples of coil driven devices include: Relays, Contactors, Solenoids, Motor starters, Motors, and Welders. This example shows a simple circuit with a small 24V/125mA/3W relay. As you can see, when the switch is opened, thereby de-energizing the coil, the transient voltage generated across the switch contacts peaks at 140V.

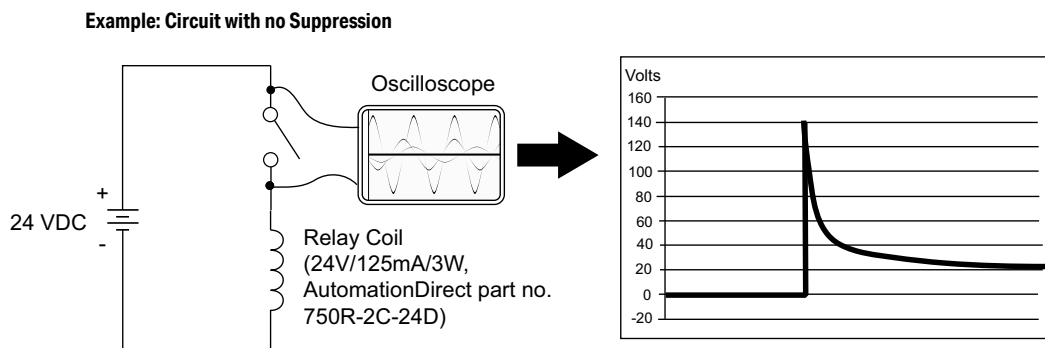

In the same circuit, replacing the relay with a larger 24V/290mA/7W relay will generate a transient voltage exceeding 800V (not shown). Transient voltages like this can cause many problems, including:

- Relay contacts driving the coil may experience arcing, which can pit the contacts and reduce the relay's lifespan.
- Solid state (transistor) outputs driving the coil can be damaged if the transient voltage exceeds the transistor's ratings. In extreme cases, complete failure of the output can occur the very first time a coil is de-energized.
- Input circuits, which might be connected to monitor the coil or the output driver, can also be damaged by the transient voltage.

A very destructive side-effect of the arcing across relay contacts is the electromagnetic interference (EMI) it can cause. This occurs because the arcing causes a current surge, which releases RF energy. The entire length of wire between the relay contacts, the coil, and the power source carries the current surge and becomes an antenna that radiates the RF energy. It will readily couple into parallel wiring and may disrupt the MPU and other electronics in the area. This EMI can make an otherwise stable control system behave unpredictably at times.

MPU's Integrated Transient Suppressors

Although the BRX MPU outputs have integrated suppressors to protect against transients, they are not capable of handling them all. It is usually necessary to have some additional transient suppression for an inductive load.

Here is another example using the same 24V/125mA/3W relay used earlier. This example measures the PNP transistor output of a typical MPU, which incorporates an integrated Zener diode for transient suppression. Instead of the 140V peak in the first example, the transient voltage here is limited to about 40V by the Zener diode. While the MPU will probably tolerate repeated transients in this range for some time, the 40V is still beyond the module's peak output voltage rating of 30V.

Example: Small Inductive Load with Only Integrated Suppression

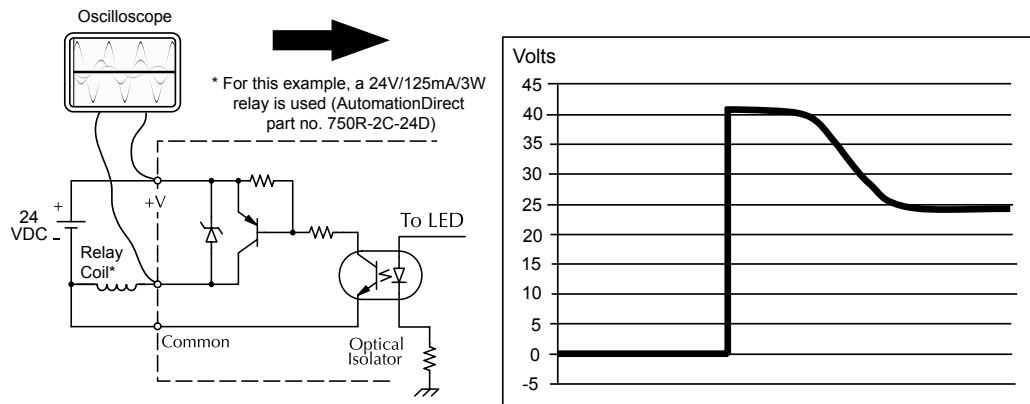

The next example uses the same circuit as above, but with a larger 24V/290mA/7W relay, thereby creating a larger inductive load. As you can see, the transient voltage generated is much worse, peaking at over 50V, yet considerably below the 800V mentioned earlier. Driving an inductive load of this size (66% above rate voltage) without additional transient suppression is very likely to permanently damage the MPU output.

Example: Larger Inductive Load with Only Integrated Suppression

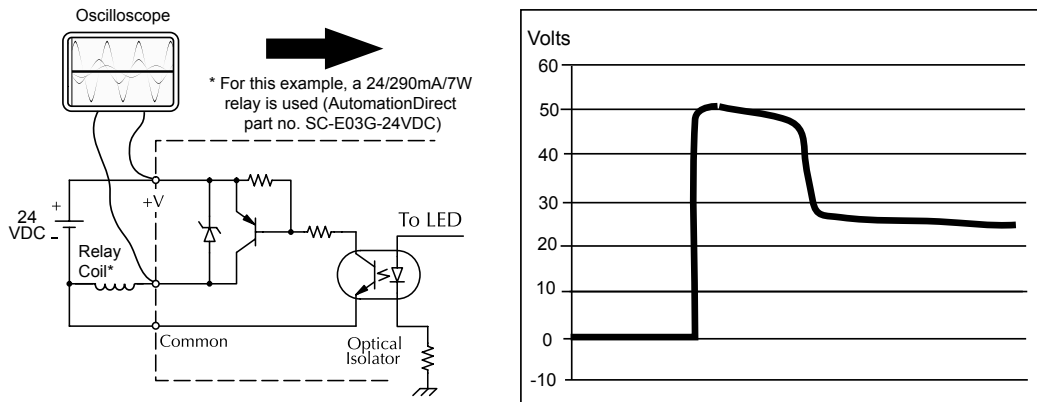

Additional transient suppression should be used in both these examples. If you are unable to measure the transients generated by the connected loads of your control system, using additional transient suppression on all inductive loads would be the safest practice.

Types of Additional Transient Protection

DC Coils:

The most effective protection against transients from a DC coil is a flyback diode. A flyback diode can reduce the transient to roughly 1V over the supply voltage, as shown in this example.

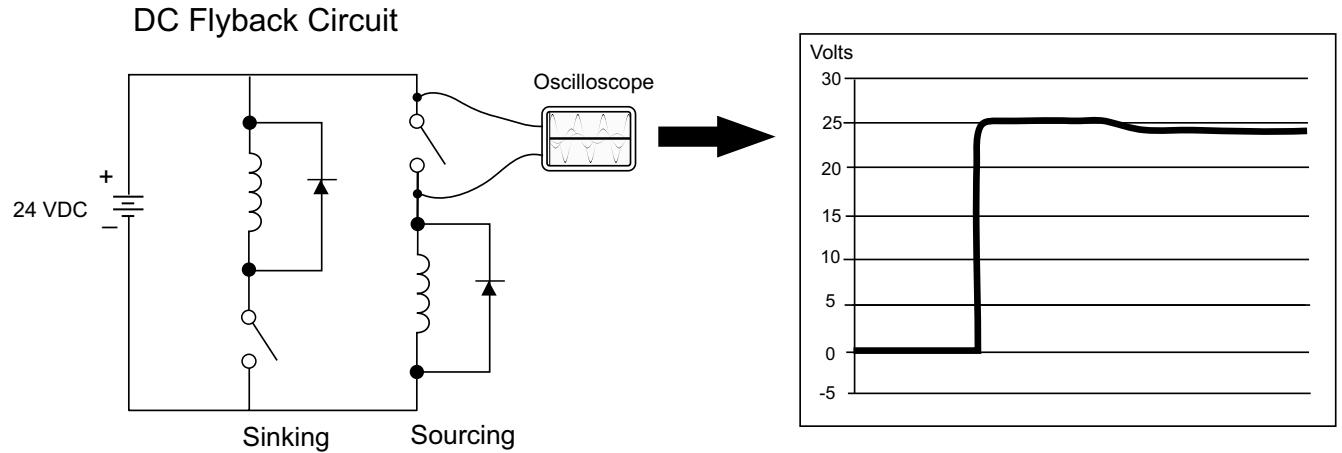

Many AutomationDirect socketed relays and motor starters have add-on flyback diodes that plug or screw into the base, such as the AD-ASMD-250 protection diode module and 784-4C-SKT-1 socket module shown below. If an add-on flyback diode is not available for your inductive load, an easy way to add one is to use AutomationDirect's DN-D10DR-A diode terminal block, a 600VDC power diode mounted in a slim DIN rail housing.



AD-ASMD-250
Protection Diode Module



784-4C-SKT-1
Relay Socket

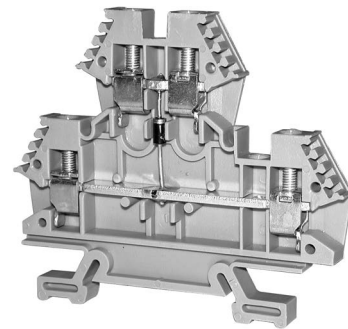

DN-D10DR-A
Diode Terminal Block

Two more common options for DC coils are Metal Oxide Varistors (MOV) or TVS diodes. These devices should be connected across the coil for best protection as shown below. The optimum voltage rating is the lowest rated voltage available for the suppressor that will NOT conduct at the supply voltage, while still allowing a safe margin.

AutomationDirect's ZL-TSD8-24 transorb module is a good choice for 24VDC circuits. It is a bank of 8 unidirectional 30V TVS diodes. Since it is unidirectional, be sure to observe the polarity during installation. MOVs or bidirectional TVS diodes would install at the same location, but have no polarity concerns.



ZL-TSD8-24
Transorb Module

DC MOV or TVS Diode Circuit

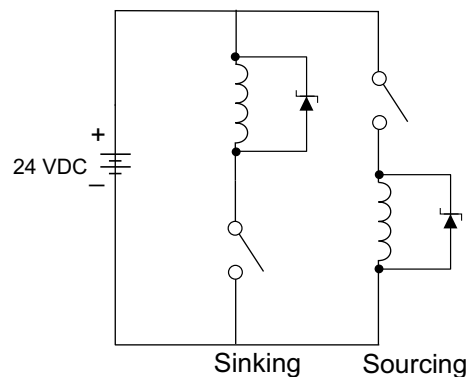

AC Coils:

Two options for AC coils are MOVs or bi-directional TVS diodes. These devices are most effective at protecting the driver from a transient voltage when connected across the coil. The optimum voltage rating for the suppressor is the lowest rated voltage available that will NOT conduct at the supply voltage, while still allowing a safe margin.

AutomationDirect's ZL-TSD8-120 transorb module is a good choice for 120VAC circuits. It is a bank of eight bi-directional 180V TVS diodes.



ZL-TSD8-120
Transorb Module

AC MOV or Bi-Directional Diode Circuit

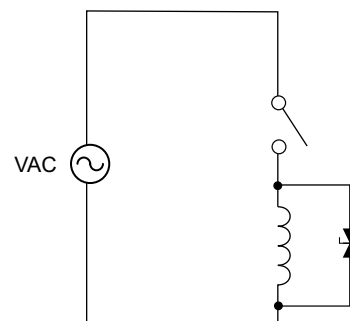

NOTE: Manufacturers of devices with coils frequently offer MOV or TVS diode suppressors as an add-on option that mount conveniently across the coil. Before using them, carefully check the suppressor ratings. Just because the suppressor is made specifically for that part does not mean it will reduce the transient voltages to an acceptable level for your application.

For example, a MOV or TVS diode rated for use on 24–48 VDC coils would need to have a high enough voltage rating to NOT conduct at 48V. That suppressor might typically start conducting at roughly 60VDC. If it were mounted across a 24V coil, transients of roughly 84V (if sinking output) or -60V (if sourcing output) could reach the MPU output. Many semiconductor MPU outputs cannot tolerate such levels.

Notes: