

ABB Robotics

Product manual DressPack/SpotPack IRB 6620



Product manual
DressPack/SpotPack
IRB 6620

M2004

Document ID: 3HAC027309-001

Revision: D

The information in this manual is subject to change without notice and should not be construed as a commitment by ABB. ABB assumes no responsibility for any errors that may appear in this manual.

Except as may be expressly stated anywhere in this manual, nothing herein shall be construed as any kind of guarantee or warranty by ABB for losses, damages to persons or property, fitness for a specific purpose or the like.

In no event shall ABB be liable for incidental or consequential damages arising from use of this manual and products described herein.

This manual and parts thereof must not be reproduced or copied without ABB's written permission, and contents thereof must not be imparted to a third party nor be used for any unauthorized purpose. Contravention will be prosecuted.

Additional copies of this manual may be obtained from ABB at its then current charge.

© Copyright 2006-2010 ABB All rights reserved.

ABB AB
Robotics Products
SE-721 68 Västerås
Sweden

| | |
|--|-----------|
| Overview of this manual | 7 |
| Product documentation, M2004 | 9 |
| How to read the product manual | 11 |
| Product name principles | 12 |
| 1 Safety | 15 |
| 1.1 Introduction | 15 |
| 1.2 General safety information. | 16 |
| 1.2.1 Safety in the manipulator system | 16 |
| 1.2.2 Safety risks | 17 |
| 1.2.2.1 Safety risks during installation and service work on manipulators. | 17 |
| 1.2.2.2 CAUTION - Hot parts may cause burns! | 19 |
| 1.2.2.3 Safety risks related to tools/workpieces | 20 |
| 1.2.2.4 Safety risks related to pneumatic/hydraulic systems. | 21 |
| 1.2.2.5 Safety risks during operational disturbances. | 22 |
| 1.2.2.6 Risks associated with live electric parts | 23 |
| 1.2.3 Safety actions | 24 |
| 1.2.3.1 Safety fence dimensions | 24 |
| 1.2.3.2 Fire extinguishing | 25 |
| 1.2.3.3 Emergency release of the manipulator's arm | 26 |
| 1.2.3.4 Brake testing | 27 |
| 1.2.3.5 Risk of disabling function "Reduced speed 250 mm/s" | 28 |
| 1.2.3.6 Safe use of the FlexPendant | 29 |
| 1.2.3.7 Work inside the manipulator's working range | 30 |
| 1.2.3.8 Signal lamp (optional). | 31 |
| 1.2.4 Safety stops. | 32 |
| 1.2.4.1 What is an emergency stop? | 32 |
| 1.3 Safety instructions | 34 |
| 1.3.1 Safety signals in the manual. | 34 |
| 1.3.2 Safety symbols on the manipulator labels | 36 |
| 1.3.3 DANGER - Moving manipulators are potentially lethal! | 40 |
| 1.3.4 DANGER - Robot without axes' holding brakes are potentially lethal! | 41 |
| 1.3.5 DANGER - No admittance for persons fitted with cardiac pacemakers | 42 |
| 2 Installation | 43 |
| 2.1 Introduction | 43 |
| 2.2 DressPack cable package | 44 |
| 2.2.1 Overview | 44 |
| 2.2.2 Installation activities. | 45 |
| 2.2.3 Fitting the attachments of the continuous cable package - IRBDP MH 2 CE and IRBDP SW 2 CE | 48 |
| 2.2.4 Fitting the attachments of the cable package - IRBDP MH 3 LE and IRBDP MH 3 UE | 55 |
| 2.2.5 Fitting the attachments of IRBDP SW5 CE (SpotPack Basic). | 61 |
| 2.2.6 Fitting the cable package IRBDP SW2 CE IRBDP MH2 CEand. | 67 |
| 2.2.7 Fitting the lower arm cable package - IRBDP MH 3 LE | 74 |
| 2.2.8 Fitting the upper arm cable package - IRBDP MH 3 UE. | 81 |
| 2.2.9 Fitting the cable package IRBDP SW5 CE (SpotPack Basic) | 86 |
| 2.2.10 Inspection, DressPack lower arm | 91 |
| 2.2.11 Inspection, DressPack upper arm | 92 |
| 2.3 DressPack adjustments | 96 |
| 2.3.1 Adjustments of - IRBDP MH2 UE and IRBDP SW2 UE | 96 |
| 2.3.2 Adjustments of the cable package - IRBDP MH3 UE | 100 |
| 2.3.3 Adjustment of the cable package - IRBDP SW5 CE (SpotPack basic) | 101 |
| 2.3.4 Inspection during programming and test-running | 103 |

Table of Contents

| | |
|--|------------|
| 2.4 DressPack Armload parameters | 106 |
| 2.4.1 DressPack - Armload parameters and LoadId | 106 |
| 2.5 DressPack floor | 109 |
| 2.5.1 Installation of DressPack floor | 109 |
| 2.5.2 Inspection, DressPack floor | 114 |
| 2.6 Water & air unit | 115 |
| 2.6.1 Installation of Water and air unit | 115 |
| 2.6.2 Return water flow control | 124 |
| 2.6.3 Return water flow switch setting | 125 |
| 2.6.4 Setting of Air pressure switch (Only applicable to type S) | 127 |
| 2.7 Spot welding cabinet | 129 |
| 2.7.1 Lifting the Spotwelding Cabinet | 129 |
| 2.7.2 Installation of Spotwelding Cabinet | 131 |
| 2.8 Installation of Tipdresser | 138 |
| 2.8.1 Installation of Tipdresser (option) | 138 |
| 3 Maintenance | 143 |
| 3.1 Introduction | 143 |
| 3.2 Maintenance schedule and component lives | 144 |
| 3.2.1 Maintenance schedule, SpotPack | 144 |
| 3.3 Inspection activities | 146 |
| 3.3.1 Preventive inspection of all cables, SpotPack | 146 |
| 3.3.2 Preventive inspection, DressPack upper end | 148 |
| 3.3.3 Preventive inspection of Water and air unit | 155 |
| 3.3.4 Preventive inspection of Spotwelding Cabinet | 158 |
| 3.4 Cleaning activities | 161 |
| 3.4.1 Cleaning, DressPack upper arm | 161 |
| 3.4.2 Cleaning, Water and air unit | 163 |
| 3.4.3 Cleaning the Fan Unit | 165 |
| 3.4.4 Cleaning the Weld Timer cooling fins | 167 |
| 4 Repair | 169 |
| 4.1 Introduction | 169 |
| 4.2 DressPack cable package | 170 |
| 4.2.1 Repair activities | 170 |
| 4.2.2 Replacement of cable package IRBDP MH2 CEandIRBDP SW2 CE | 171 |
| 4.2.3 Replacement of the lower arm cable package - IRBDP MH 3 LE | 177 |
| 4.2.4 Replacement of upper arm cable package - IRBDP MH 3 UE | 182 |
| 4.2.5 Replacing the cable package IRBDP SW5 CE (SpotPack Basic) | 185 |
| 4.2.6 Replacement of tension arm unit | 189 |
| 4.2.7 Replacement of protective sleeves | 192 |
| 4.2.8 Repair of process cable package | 195 |
| 4.2.9 Adjusting tension arm unit | 200 |
| 4.3 DressPack cable package, common | 205 |
| 4.3.1 Replacement of hose reinforcement | 205 |
| 4.3.2 Replacement of slide sleeves | 208 |
| 4.4 Water and Air unit | 213 |
| 4.4.1 Replacement of Air supply circuit | 213 |
| 4.4.2 Replacement of Water-in circuit | 216 |
| 4.4.3 Replacement of Water-return circuit | 218 |
| 4.4.4 Replacement of Air filter element | 221 |

| | |
|---|------------|
| 4.5 Spotwelding cabinet | 223 |
| 4.5.1 Replacement of Weld Timer | 223 |
| 4.5.2 Replacement of Bosch weld timer battery | 227 |
| 4.5.3 Replacement of Circuit Breaker | 229 |
| 4.5.4 Replacement of door interlock | 234 |
| 4.5.5 Replacement of contactor | 239 |
| 4.5.6 Replacement of external residual current release | 242 |
| 4.6 Tipdresser | 245 |
| 4.6.1 Replacement of Tipdresser parts | 245 |
| 5 Decommissioning | 247 |
| 5.1 Environmental information | 247 |
| 6 Reference information | 249 |
| 6.1 Introduction | 249 |
| 6.2 Applicable safety standards | 250 |
| 6.3 Unit conversion | 252 |
| 6.4 Screw joints | 253 |
| 6.5 Weight specifications | 256 |
| 6.6 Toolkits, DressPack/SpotPack | 257 |
| 6.7 Lifting equipment and lifting instructions | 259 |
| 7 Spare parts | 261 |
| 7.1 Introduction | 261 |
| 7.2 DressPack IRB 6620 | 262 |
| 7.2.1 DressPack for - IRBDP MH 2 CE and IRBDP SW 2 CE | 262 |
| 7.2.2 DressPack cable package lower arm - IRBDP MH 3 LE | 264 |
| 7.2.3 DressPack cable package upper arm - IRBDP MH 3 UE | 265 |
| 7.2.4 SpotPack Basic cable package - IRBDP SW 5 CE | 266 |
| 7.2.5 Connection kits | 268 |
| 7.2.6 7:th axis to base | 269 |
| 7.2.7 Customer signal/power | 270 |
| 7.2.8 DressPack - Water and air unit | 271 |
| 7.3 Spotwelding cabinet | 272 |
| 7.3.1 Spotwelding Cabinet IRC 5, 3HAC025036-001 | 272 |
| 8 Circuit diagram | 283 |
| 8.1 About circuit diagrams | 283 |
| Index | 285 |

Overview of this manual

About this manual

This manual contains instructions for:

- mechanical and electrical work for DressPack/SpotPack systems
- maintenance of the DressPack/SpotPack systems
- mechanical and electrical repair of the DressPack/SpotPack systems.

The manual also contains reference information for all procedures detailed in this manual.

Usage

This manual shall be used during:

- installation on the DressPack/SpotPack system
- maintenance on the DressPack/SpotPack system
- repair work on the DressPack/SpotPack system.

Who should read this manual?

This manual is intended for:

- installation personnel
- maintenance personnel
- repair personnel.

Prerequisites

A maintenance/repair/ installation craftsman working with an ABB Robot must:

- be trained by ABB and have the required knowledge of mechanical and electrical installation/repair/maintenance work.

Organization of chapters

The manual is organized in the following chapters:

| Chapter | Contents |
|-----------------------|---|
| Safety | Safety information that must be read through before performing any installation or service work on the robot. Contains general safety aspects as well as more specific information on how to avoid personal injuries and damage to the product. |
| Installation | Descriptions of mechanical installation and electrical connections. |
| Maintenance | Descriptions of all required preventive maintenance procedures including intervals. |
| Repair | Descriptions of all recommended repair procedures. |
| Decommissioning | Environmental information about the components. |
| Reference information | Useful information when performing installation, maintenance or repair work. Includes lists of necessary tools, additional documents, safety standards, etc. |
| Spare parts | Complete spare part list including wear parts shown in exploded views. |
| Circuit diagrams | References to article numbers for circuit diagrams. |

Continues on next page

Continued

References

| Reference | Document ID |
|--|----------------|
| Product specification - IRB 6620 | 3HAC025861-001 |
| Product manual - IRB 6620 | 3HAC027151-001 |
| Product manual - IRC5 | 3HAC021313-001 |
| Circuit diagrams, IRB 6620 | 3HAC025090-001 |
| Circuit diagram, DressPack | 3HAC026136-001 |
| Circuit diagram, SpotPack | 3HAC026208-001 |
| Operating manual - IRC5 with FlexPendant | 3HAC16590-1 |
| Technical reference manual - System parameters | 3HAC17076-1 |

Revisions

| Revision | Description |
|----------|---|
| - | First edition. |
| A | <p>The following has been added or changed:</p> <ul style="list-style-type: none"> • New section in the <i>Repair</i> chapter, <i>Water and air unit IRBWA 2</i>, is added. • Cable packages <i>IRBDP MH 3 LE</i> and <i>IRBDP MH 3 UE</i> added. • Product name principle is changed. (Detailed in section Product name principles on page 12.) • Sections Earth fault protection on page 135 and Contactor on page 136 added in <i>Installation of Spotwelding cabinet</i>. |
| B | <p>The following has been added or changed:</p> <ul style="list-style-type: none"> • The process cable package <i>IRBDP SW 5 CE</i> (SpotPack Basic) has been implemented throughout the manual. • Chapter <i>Spotwelding Cabinet</i> has been updated. |
| C | <p>The following has been added or changed:</p> <ul style="list-style-type: none"> • List of spare parts for upper arm cable package updated, DressPack cable package upper arm - IRBDP MH 3 UE on page 265. |
| D | <p>The following has been added or changed:</p> <ul style="list-style-type: none"> • List of spare parts updated with new spare part number for Ethernet cables. • Corrected spare part numbers, see SpotPack Basic cable package - IRBDP SW 5 CE on page 266. • Decommissioning chapter added. • Circuit diagrams are not included in this document but delivered as separate files. See About circuit diagrams on page 283. • List of standards updated, see Applicable safety standards on page 250. <p>The chapter <i>Safety</i> is updated with:</p> <ul style="list-style-type: none"> • Updated safety signal graphics for the levels <i>Danger</i> and <i>Warning</i>, see Safety signals in the manual on page 34. • New safety labels on the manipulators, see Safety symbols on the manipulator labels on page 36. • Revised terminology: <i>robot</i> replaced with <i>manipulator</i>. |

© Copyright 2006-2010 ABB. All rights reserved.

Product documentation, M2004

Categories for manipulator documentation

The manipulator documentation is divided into a number of categories. This listing is based on the type of information in the documents, regardless of whether the products are standard or optional.

All documents listed can be ordered from ABB on a DVD. The documents listed are valid for M2004 manipulator systems.

Product manuals

Manipulators, controllers, DressPack/SpotPack, and most other hardware will be delivered with a **Product manual** that generally contains:

- Safety information.
 - Installation and commissioning (descriptions of mechanical installation or electrical connections).
 - Maintenance (descriptions of all required preventive maintenance procedures including intervals and expected life time of parts).
 - Repair (descriptions of all recommended repair procedures including spare parts).
 - Calibration.
 - Decommissioning.
 - Reference information (safety standards, unit conversions, screw joints, lists of tools).
 - Spare parts list with exploded views (or references to separate spare parts lists).
 - Circuit diagrams (or references to circuit diagrams).
-

Technical reference manuals

The technical reference manuals describe the manipulator software in general and contain relevant reference information.

- **RAPID Overview:** An overview of the RAPID programming language.
- **RAPID Instructions, Functions and Data types:** Description and syntax for all RAPID instructions, functions, and data types.
- **RAPID Kernel:** A formal description of the RAPID programming language.
- **System parameters:** Description of system parameters and configuration workflows.

Continued

Application manuals

Specific applications (for example software or hardware options) are described in **Application manuals**. An application manual can describe one or several applications.

An application manual generally contains information about:

- The purpose of the application (what it does and when it is useful).
 - What is included (for example cables, I/O boards, RAPID instructions, system parameters, CD with PC software).
 - How to install included or required hardware.
 - How to use the application.
 - Examples of how to use the application.
-

Operating manuals

The operating manuals describe hands-on handling of the products. The manuals are aimed at those having first-hand operational contact with the product, that is production cell operators, programmers, and trouble shooters.

The group of manuals includes (among others):

- **Emergency safety information**
- **General safety information**
- **Getting started, IRC5 and RobotStudio**
- **Introduction to RAPID**
- **IRC5 with FlexPendant**
- **RobotStudio**
- **Trouble shooting**, for the controller and manipulator.

How to read the product manual

Reading the procedures

The procedures contain references to figures, tools, material, and so on. The references are read as described below.

References to figures

The procedures often include references to components or attachment points located on the manipulator/controller. The components or attachment points are marked with *italic text* in the procedures and completed with a reference to the figure where the current component or attachment point is shown.

The denomination in the procedure for the component or attachment point corresponds to the denomination in the referenced figure.

The table below shows an example of a reference to a figure from a step in a procedure.

| | Action | Note/Illustration |
|----|---|---|
| 8. | Remove the <i>rear attachment screws, gearbox</i> . | Shown in the figure <i>Location of gearbox on page xx</i> . |

References to required equipment

The procedures often include references to equipment (spare parts, tools, etc.) required for the different actions in the procedure. The equipment is marked with *italic text* in the procedures and completed with a reference to the section where the equipment is listed with further information, that is article number and dimensions.

The designation in the procedure for the component or attachment point corresponds to the designation in the referenced list.

The table below shows an example of a reference to a list of required equipment from a step in a procedure.

| | Action | Note/Illustration |
|----|--|---|
| 3. | Fit a new <i>sealing, axis 2</i> to the gearbox. | Art. no. is specified in <i>Required equipment on page xx</i> . |

Safety information

The manual includes a separate safety chapter that must be read through before proceeding with any service or installation procedures. All procedures also include specific safety information when dangerous steps are to be performed.

Read more in the chapter *Safety*.

Product name principles

General

The different robots has a wide range of options. In many cases the option name gives a good explanation of its content. In some cases there is a need to add more information in the product name in order to clearly show a certain variant and to avoid misunderstandings. Hence a complementary naming standard is used.

The family name of the options is DressPack (that is customer cables and hoses from the controller to the robot's axis 6, divided in different sections).

DressPack parts

DressPack parts that are assembled on the robot are called:

- **IRBDP** (IRB DressPack)

Main application

The DressPack has been prepared for two main applications:

| Product name | Application |
|--------------|-------------------|
| MH | Material handling |
| SW | Spotwelding |

Generations

The different generations of a DressPack is indicated with a generation number. The number indicates the different design of each generation. (Some generations might not be available since it has been phased out).

- **1, 2, 3** etc

Sections

The DressPack on the robot is supplied in different sections:

| Product name | Section |
|--------------|--|
| L | Lower DressPack section |
| U | Upper DressPack section |
| C | Continuous DressPack (DressPack without an intermediate connection point) |

Routing

The DressPack can be routed in different ways:

| Product name | Routing |
|--------------|---|
| I | Integrated DressPack The main parts are integrated within the robot structure. |
| E | External DressPack The main parts are routed outside, on the robot structure. |

Examples

- **IRBDP MH 3 UE** = IRB DressPack / Material handling application / Generation 3 / Upper arm DressPack section / External routing
- **IRBDP SW 4 UI** = IRB DressPack / Spotwelding application / Generation 4 / Upper arm DressPack section / Internal routing
- **IRBDP SW 2 LE** = IRB DressPack / Spotwelding application / Generation 2 / Lower arm DressPack section / External routing
- **IRBDP SW 2 CE** = IRB DressPack / Spotwelding application / Generation 2 / Continuous DressPack section / External routing

1 Safety

1.1. Introduction

Overview

The safety information in this manual is divided in two categories:

- General safety aspects, important to attend to before performing any service work on the controller. These are applicable for all service work and are found in section *General safety information*.
- Specific safety information, pointed out in the procedure at the moment of the danger. How to avoid and eliminate the danger is either detailed directly in the procedure, or further detailed in separate instructions, found in section *Safety related instructions*.

1 Safety

1.2.1. Safety in the manipulator system

1.2 General safety information

1.2.1. Safety in the manipulator system

Validity and responsibility

The information does not cover how to design, install and operate a complete system, nor does it cover all peripheral equipment that can influence the safety of the entire system. To protect personnel, the complete system must be designed and installed in accordance with the safety requirements set forth in the standards and regulations of the country where the manipulator is installed.

The users of ABB industrial manipulators are responsible for ensuring that the applicable safety laws and regulations in the country concerned are observed and that the safety devices necessary to protect people working with the manipulator system are designed and installed correctly. Personnel working with manipulators must be familiar with the operation and handling of the industrial manipulator as described in the applicable documents, for example:

- *Operating manual - IRC5 with FlexPendant*
- *Product manual*

Connection of external safety devices

Apart from the built-in safety functions, the manipulator is also supplied with an interface for the connection of external safety devices. An external safety function can interact with other machines and peripheral equipment via this interface. This means that control signals can act on safety signals received from the peripheral equipment as well as from the manipulator.

Limitation of liability

Any information given in this manual regarding safety must not be construed as a warranty by ABB that the industrial manipulator will not cause injury or damage even if all safety instructions are complied with.

Related information

| Type of information | Detailed in document | Section |
|--------------------------------|--|--------------------------------|
| Installation of safety devices | Product manual for the manipulator | Installation and commissioning |
| Changing operating modes | Operating manual - IRC5 with FlexPendant | Operating modes |
| Restricting the working space | Product manual for the manipulator | Installation and commissioning |

1.2.2. Safety risks

1.2.2.1. Safety risks during installation and service work on manipulators

Overview

This section includes information on general safety risks to be considered when performing installation and service work on the manipulator.

General risks during installation and service

- The instructions in the Product manual in the chapter *Installation and commissioning* must always be followed.
- Emergency stop buttons must be positioned in easily accessible places so that the manipulator can be stopped quickly.
- Those in charge of operations must make sure that safety instructions are available for the installation in question.
- Those who install the manipulator must have the appropriate training for the equipment in question and in any safety matters associated with it.

Nation/region specific regulations

To prevent injuries and damages during the installation of the manipulator, the regulations applicable in the country concerned and the instructions of ABB Robotics must be complied with.

Non-voltage related risks

- Safety zones, which must be crossed before admittance, must be set up in front of the manipulator's working space. Light beams or sensitive mats are suitable devices.
- Turntables or the like should be used to keep the operator out of the manipulator's working space.
- The axes are affected by the force of gravity when the brakes are released. In addition to the risk of being hit by moving manipulator parts, there is a risk of being crushed by the parallel arm (if there is one).
- Energy stored in the manipulator for the purpose of counterbalancing certain axes may be released if the manipulator, or parts thereof, are dismantled.
- When dismantling/assembling mechanical units, watch out for falling objects.
- Be aware of stored heat energy in the controller.
- Never use the manipulator as a ladder, that is, do not climb on the manipulator motors or other parts during service work. There is a serious risk of slipping because of the high temperature of the motors or oil spills that can occur on the manipulator.

To be observed by the supplier of the complete system

- The supplier of the complete system must ensure that all circuits used in the safety function are interlocked in accordance with the applicable standards for that function.
- The supplier of the complete system must ensure that all circuits used in the emergency stop function are interlocked in a safe manner, in accordance with the applicable standards for the emergency stop function.



Continues on next page

1 Safety

1.2.2.1. Safety risks during installation and service work on manipulators

Continued

Complete manipulator

| Safety risk | Description |
|--|---|
| Hot components! |  CAUTION! Motors and gears are HOT after running the manipulator! Touching motors and gears may result in burns! With a higher environment temperature, more surfaces on the manipulator will get HOT and may also result in burns. |
| Removed parts may result in collapse of manipulator! |  WARNING! Take any necessary measures to ensure that the manipulator does not collapse as parts are removed, e.g. secure the lower arm with fixtures if removing motor, axis 2. |

Cabling

| Safety risk | Description |
|---|--|
| Cable packs are sensitive to mechanical damage! |  CAUTION! The cable packs are sensitive to mechanical damage! They must be handled with care, especially the connectors, in order to avoid damaging them! |

1.2.2.2. CAUTION - Hot parts may cause burns!

Description

During normal operation, many manipulator parts become hot, especially the drive motors and gears. Sometimes areas around these parts also become hot. Touching these may cause burns of various severity.

Because of a higher environment temperature, more surfaces on the manipulator get hot and may result in burns.

Elimination

The instructions below detail how to avoid the dangers specified above:

| | Action | Info |
|----|--|------|
| 1. | Always use your hand, at some distance, to feel if heat is radiating from the potentially hot component before actually touching it. | |
| 2. | Wait until the potentially hot component has cooled if it is to be removed or handled in any other way. | |

1 Safety

1.2.2.3. Safety risks related to tools/workpieces

1.2.2.3. Safety risks related to tools/workpieces

Safe handling

It must be possible to safely turn off tools, such as milling cutters, etc. Make sure that guards remain closed until the cutters stop rotating.

It should be possible to release parts by manual operation (valves).

Safe design

Grippers/end effectors must be designed so that they retain workpieces in the event of a power failure or a disturbance to the controller.



CAUTION!

Ensure that a gripper is prevented from dropping a workpiece, if such is used.

1.2.2.4. Safety risks related to pneumatic/hydraulic systems

General

Special safety regulations apply to pneumatic and hydraulic systems.

Residual energy

- Residual energy can be present in these systems. After shutdown, particular care must be taken.
 - The pressure in pneumatic and hydraulic systems must be released before starting to repair them.
-

Safe design

- Gravity may cause any parts or objects held by these systems to drop.
- Dump valves should be used in case of emergency.
- Shot bolts should be used to prevent tools, etc., from falling due to gravity.

1 Safety

1.2.2.5. Safety risks during operational disturbances

1.2.2.5. Safety risks during operational disturbances

General

- The industrial manipulator is a flexible tool that can be used in many different industrial applications.
- All work must be carried out professionally and in accordance with the applicable safety regulations.
- Care must be taken at all times.

Qualified personnel

Corrective maintenance must only be carried out by qualified personnel who are familiar with the entire installation as well as the special risks associated with its different parts.

Extraordinary risks

If the working process is interrupted, extra care must be taken due to risks other than those associated with regular operation. Such an interruption may have to be rectified manually.

1.2.2.6. Risks associated with live electric parts

Voltage related risks, general

- Although troubleshooting may, on occasion, need to be carried out while the power supply is turned on, the robot must be turned off (by setting the mains switch to OFF) when repairing faults, disconnecting electric leads and disconnecting or connecting units.
- The mains supply to the robot must be connected in such a way that it can be turned off from outside the robot's working space.

Voltage related risks, IRC5 controller

A danger of high voltage is associated with, for example, the following parts:

- Be aware of stored electrical energy (DC link, Ultracapacitor bank unit) in the controller.
- Units such as I/O modules, can be supplied with power from an external source.
- The mains supply/mains switch
- The transformers
- The power unit
- The control power supply (230 VAC)
- The rectifier unit (400-480 VAC and 700 VDC. Note: Capacitors!)
- The drive unit (700 VDC)
- The drive system power supply (230 VAC)
- The service outlets (115/230 VAC)
- The customer power supply (230 VAC)
- The power supply unit for additional tools, or special power supply units for the machining process.
- The external voltage connected to the controller remains live even when the robot is disconnected from the mains.
- Additional connections.

Voltage related risks, manipulator

A danger of high voltage is associated with the manipulator in:

- The power supply for the motors (up to 800 VDC).
- The user connections for tools or other parts of the installation (max. 230 VAC, see the chapter *Installation and commissioning* in the Product manual).

Voltage related risks, tools, material handling devices, etc.

Tools, material handling devices, etc., may be live even if the robot system is in the OFF position. Power supply cables which are in motion during the working process may be damaged.

1 Safety

1.2.3.1. Safety fence dimensions

1.2.3. Safety actions

1.2.3.1. Safety fence dimensions

General

Install a safety cell around the manipulator to ensure safe manipulator installation and operation.

Dimensioning

Dimension the fence or enclosure to enable it to withstand the force created if the load being handled by the manipulator is dropped or released at maximum speed. Determine the maximum speed from the maximum velocities of the manipulator axes and from the position at which the manipulator is working in the work cell (see the section *Robot motion* in the *Product specification*).

Also consider the maximum possible impact caused by a breaking or malfunctioning rotating tool or other device fitted to the manipulator.

1.2.3.2. Fire extinguishing



NOTE!

Use a CARBON DIOXIDE (CO₂) extinguisher in the event of a fire in the manipulator system (manipulator or controller)!

1 Safety

1.2.3.3. Emergency release of the manipulator's arm

1.2.3.3. Emergency release of the manipulator's arm

Description

In an emergency situation, any of the manipulator's axes may be released manually by pushing the brake release buttons on the manipulator.

How to release the brakes is detailed in the section:

- *Manually releasing the brakes* in the product manual for the manipulator.
- *Manually releasing the brakes*.

The manipulator arm may be moved manually on smaller manipulator models, but larger models may require using an overhead crane or similar equipment.

Increased injury

Before releasing the brakes, make sure that the weight of the arms does not increase the pressure on the trapped person, further increasing any injury!

1.2.3.4. Brake testing

When to test

During operation, the holding brake of each axis normally wears down. A test can be performed to determine whether the brake can still perform its function.

How to test

The function of the holding brake of each axis motor may be checked as described below:

1. Run each manipulator axis to a position where the combined weight of the manipulator arm and any load is maximized (max. static load).
2. Switch the motor to the MOTORS OFF position with the operating mode selector on the controller.
3. Check that the axis maintains its position.

If the manipulator does not change position as the motors are switched off, then the brake function is adequate.

1 Safety

1.2.3.5. Risk of disabling function "Reduced speed 250 mm/s"



NOTE!

Do not change *Transm gear ratio* or other kinematic system parameters from the FlexPendant or a PC. This will affect the safety function "Reduced speed 250 mm/s".

1.2.3.6. Safe use of the FlexPendant



NOTE!

The enabling device is a push-button located on the side of the FlexPendant which, when pressed halfway in, switches the system to MOTORS ON. When the enabling device is released or pushed all the way in, the manipulator switches to the MOTORS OFF state.

To ensure safe use of the FlexPendant, the following must be implemented:

- The enabling device must never be rendered inoperational in any way.
- During programming and testing, the enabling device must be released as soon as there is no need for the manipulator to move.
- The programmer must always bring the FlexPendant with him/her when entering the manipulator's working space. This is to prevent anyone else from taking control of the manipulator without the programmer's knowledge.

Enabling device

The enabling device is a manually operated, constant pressure push-button which, when continuously activated in one position only, allows potentially hazardous functions but does not initiate them. In any other position, hazardous functions are stopped safely.

The enabling device is of a specific type where you must press the push-button only half-way to activate it. In the fully in and fully out positions, manipulator operation is impossible.

Hold-to-run function

The hold-to-run function allows movement when a button connected to the function is actuated manually and immediately stops any movement when released. The hold-to-run function can only be used in manual mode.

How to operate the hold-to-run function is described in *Operating manual - IRC5 with FlexPendant*.

1.2.3.7. Work inside the manipulator's working range



WARNING!

If work must be carried out within the manipulator's work area, the following points must be observed:

- The operating mode selector on the controller must be in the manual mode position to render the enabling device operational and to block operation from a computer link or remote control panel.
- The manipulator's speed is limited to max. 250 mm/s when the operating mode selector is in the position *Manual mode with reduced speed*. This should be the normal position when entering the working space. The position *Manual mode with full speed (100%)* may only be used by trained personnel who are aware of the risks that this entails. *Manual mode with full speed (100%)* is not available in USA or Canada.
- Pay attention to the rotating axes of the manipulator. Keep away from axes to not get entangled with hair or clothing. Also, be aware of any danger that may be caused by rotating tools or other devices mounted on the manipulator or inside the cell.
- Test the motor brake on each axis, according to the section [Brake testing on page 27](#).



WARNING!

NEVER, under any circumstances, stay beneath any of the manipulator's axes! There is always a risk that the manipulator will move unexpectedly when manipulator axes are moved using the enabling device or during other work inside the manipulator's working range.

1.2.3.8. Signal lamp (optional)

Description

A signal lamp with a yellow fixed light can be mounted on the manipulator, as a safety device.

Function

The lamp is active in MOTORS ON mode.

Further information

Further information about the MOTORS ON/MOTORS OFF mode may be found in the product manual for the controller.

1 Safety

1.2.4.1. What is an emergency stop?

1.2.4. Safety stops

1.2.4.1. What is an emergency stop?

Definition of emergency stop

An emergency stop is a state that overrides any other manipulator control, disconnects drive power from the manipulator motors, stops all moving parts and disconnects power from any potentially dangerous functions controlled by the manipulator system.

An emergency stop state means that all power is disconnected from the manipulator except for the manual brake release circuits. You must perform a recovery procedure, i.e. resetting the emergency stop button and pressing the Motors On button, in order to return to normal operation.

The manipulator system can be configured so that the emergency stop results in either:

- An uncontrolled stop, immediately stopping the manipulator actions by disconnecting power from the motors.
- A controlled stop, stopping the manipulator actions with power available to the motors so that the manipulator path can be maintained. When completed, power is disconnected from the motors.

The default setting is uncontrolled stop. However, controlled stops are preferred since they minimize extra, unnecessary wear on the manipulator and the actions needed to return the manipulator system back to production. Please consult your plant or cell documentation to see how your manipulator system is configured.



NOTE!

The emergency stop function may only be used for the purpose and under the conditions for which it is intended.



NOTE!

The emergency stop function is intended for immediately stopping equipment in the event of an emergency.



NOTE!

Emergency stop should not be used for normal program stops as this causes extra, unnecessary wear on the manipulator. For how to perform normal program stops, see the section *Stopping programs* in *Operating manual - IRC5 with FlexPendant*.

Classification of stops

The safety standards that regulate automation and manipulator equipment define categories in which each type of stop applies:

| If the stop is... | ... then it is classified as... |
|-------------------|---------------------------------|
| uncontrolled | category 0 (zero) |
| controlled | category 1 |

Continued

Emergency stop devices

In a manipulator system there are several emergency stop devices that can be operated in order to achieve an emergency stop. There are emergency stop buttons available on the FlexPendant and on the controller cabinet (on the Control Module on a Dual Cabinet Controller). There can also be other types of emergency stops on your manipulator. Consult your plant or cell documentation to see how your manipulator system is configured.

1 Safety

1.3.1. Safety signals in the manual

1.3 Safety instructions

1.3.1. Safety signals in the manual





Introduction to safety signals

This section specifies all dangers that can arise when doing the work described in this manual. Each danger consists of:

- A caption specifying the danger level (DANGER, WARNING, or CAUTION) and the type of danger.
- A brief description of what will happen if the operator/service personnel **do not** eliminate the danger.
- Instruction about, how to eliminate danger to simplify doing the work.

Danger levels



The table below defines the captions specifying the danger levels used throughout this manual.

| Symbol | Designation | Significance |
|---|------------------|---|
|  danger | DANGER | Warns that an accident <i>will</i> occur if the instructions are not followed, resulting in a serious or fatal injury and/or severe damage to the product. It applies to warnings that apply to danger with, for example, contact with high voltage electrical units, explosion or fire risk, risk of poisonous gases, risk of crushing, impact, fall from height, and so on. |
|  warning | WARNING | Warns that an accident <i>may</i> occur if the instructions are not followed that can lead to serious injury, possibly fatal, and/or great damage to the product. It applies to warnings that apply to danger with, for example, contact with high voltage electrical units, explosion or fire risk, risk of poisonous gases, risk of crushing, impact, fall from height, etc. |
|  Electrical shock | ELECTRICAL SHOCK | Warns for electrical hazards which could result in severe personal injury or death. |
|  caution | CAUTION | Warns that an accident may occur if the instructions are not followed that can result in injury and/or damage to the product. It also applies to warnings of risks that include burns, eye injury, skin injury, hearing damage, crushing or slipping, tripping, impact, fall from height, etc. Furthermore, it applies to warnings that include function requirements when fitting and removing equipment where there is a risk of damaging the product or causing a breakdown. |

© Copyright 2006-2010 ABB. All rights reserved.

Continues on next page

Continued

| Symbol | Designation | Significance |
|--|-------------------------------|--|
|  Electrostatic discharge (ESD) | ELECTROSTATIC DISCHARGE (ESD) | Warns for electrostatic hazards which could result in severe damage to the product. |
|  Note | NOTE | Describes important facts and conditions. |
|  Tip | TIP | Describes where to find additional information or how to do an operation in an easier way. |

1 Safety

1.3.2. Safety symbols on the manipulator labels

1.3.2. Safety symbols on the manipulator labels

Introduction to labels

This section describes safety symbols used on labels (stickers) on the manipulator. Symbols are used in combinations on the labels, describing each specific warning. The descriptions in this section are generic, the labels can contain additional information such as values.



Types of labels

Both the manipulator and the controller are marked with several safety and information labels, containing important information about the product. The information is useful for all personnel handling the manipulator system, for example during installation, service, or operation.

The safety labels are language independent, they only use graphics. See [Symbols on safety labels on page 36](#).

The information labels can contain information in text (English, German, and French).





Symbols on safety labels

| Symbol | Description |
|---|--|
|  xx0900000812 | Warning! Warns that an accident <i>may</i> occur if the instructions are not followed that can lead to serious injury, possibly fatal, and/or great damage to the product. It applies to warnings that apply to danger with, for example, contact with high voltage electrical units, explosion or fire risk, risk of poisonous gases, risk of crushing, impact, fall from height, etc. |
|  xx0900000811 | Caution! Warns that an accident may occur if the instructions are not followed that can result in injury and/or damage to the product. It also applies to warnings of risks that include burns, eye injury, skin injury, hearing damage, crushing or slipping, tripping, impact, fall from height, etc. Furthermore, it applies to warnings that include function requirements when fitting and removing equipment where there is a risk of damaging the product or causing a breakdown. |
|  xx0900000839 | Prohibition Used in combinations with other symbols. |

© Copyright 2006-2010 ABB. All rights reserved.

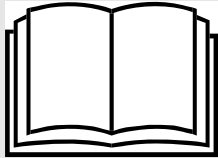
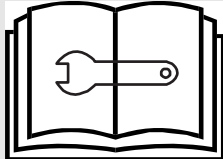
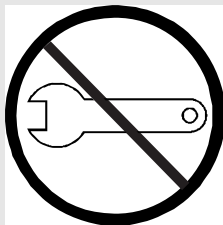
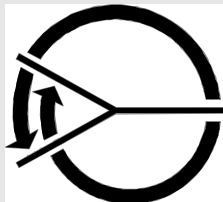
Continues on next page

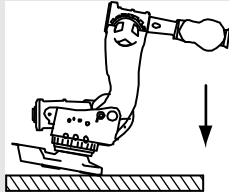



Continued

| Symbol | Description |
|---|--|
|  <p>xx0900000813</p> | <p>Product manual Read the product manual for details.</p> |
|  <p>xx0900000816</p> | <p>Before dismantling see product manual</p> |
|  <p>xx0900000815</p> | <p>Do not dismantle Dismantling this part can cause injury.</p> |
|  <p>xx0900000814</p> | <p>Extended rotation This axis has extended rotation (working area) compared to standard.</p> |
|  <p>xx0900000808</p> | <p>Brake release Pressing this button will release the brakes. This means that the manipulator arm can fall down.</p> |
|  <p>xx0900000810</p> | <p>Tip risk when loosening bolts The manipulator can tip over if the bolts are not securely fastened.</p> |
|  <p>xx0900000817</p> | <p>Crush Risk of crush injuries.</p> |

1 Safety

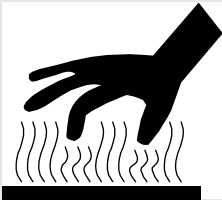
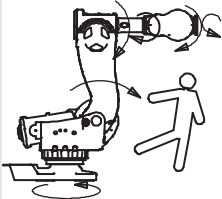

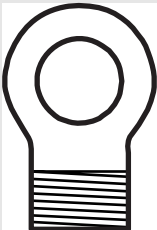
1.3.2. Safety symbols on the manipulator labels

Continued

| Symbol | Description |
|---|--|
|  xx0900000818 | Heat Risk of heat that can cause burns. |
|  xx0900000819 | Moving robot The robot can move unexpectedly. |
|  xx0900000820 | Brake release buttons |
|  xx0900000821 | Lifting bolt |
|  xx0900000822 | Lifting of robot |
|  xx0900000823 | Oil Can be used in combination with prohibition if oil is not allowed. |

© Copyright 2006-2010 ABB. All rights reserved.

Continued

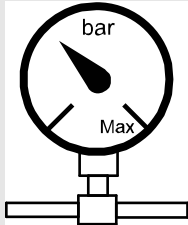
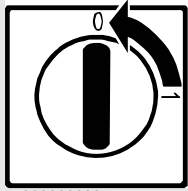
| Symbol | Description |
|---|---|
|  <p>xx0900000824</p> | <p>Mechanical stop</p> |
|  <p>xx0900000825</p> | <p>Stored energy Warns that this part contains stored energy. Used in combination with <i>Do not dismantle</i> symbol.</p> |
|  <p>xx0900000826</p> | <p>Pressure Warns that this part is pressurized. Usually contains additional text with the pressure level.</p> |
|  <p>xx0900000827</p> | <p>Shut off with handle Use the power switch on the controller.</p> |

1 Safety

1.3.3. DANGER - Moving manipulators are potentially lethal!

1.3.3. DANGER - Moving manipulators are potentially lethal!

Description

Any moving manipulator is a potentially lethal machine.

When running, the manipulator may perform unexpected and sometimes irrational movements. Moreover, all movements are performed with great force and may seriously injure any personnel and/or damage any piece of equipment located within the working range of the manipulator.

Elimination

| | Action | Note |
|----|--|---|
| 1. | Before attempting to run the manipulator, make sure all <i>emergency stop equipment</i> is correctly installed and connected. | Emergency stop equipment such as gates, tread mats, light curtains, etc. |
| 2. | Usually the hold-to-run function is active only in manual full speed mode. To increase safety it is also possible to activate hold-to-run for manual reduced speed with a system parameter. The hold-to-run function is used in manual mode, not in automatic mode. | How to use the hold-to-run function is described in section <i>How to use the hold-to-run function</i> in the <i>Operating manual - IRC5 with FlexPendant</i> . |
| 3. | Make sure no personnel are present within the working range of the manipulator before pressing the start button. | |



1.3.4. DANGER - Robot without axes' holding brakes are potentially lethal!

1.3.4. DANGER - Robot without axes' holding brakes are potentially lethal!

Description

Since the robot arm system is quite heavy, especially on larger robot models, it is dangerous if the holding brakes are disconnected, faulty, worn or in any way rendered non-operational. For instance, a collapsing IRB 7600 arm system may kill or seriously injure a person standing beneath it.

Elimination

| Action | Info/illustration |
|---|---|
| 1. If you suspect that the holding brakes are non-operational, secure the robot arm system by some other means before working on it. | Weight specifications etc. may be found in the <i>Product manual</i> of each robot model. |
| 2. If you intentionally render the holding brakes non-operational by connecting an external voltage supply, the utmost care must be taken!  DANGER! NEVER stand inside the robot working area when disabling the holding brakes unless the arm system is supported by some other means!  DANGER! Under no circumstance stand beneath any of the robot's axes! | How to correctly connect an external voltage supply is detailed in the <i>Product manual</i> of each robot model. |

1 Safety

1.3.5. DANGER - No admittance for persons fitted with cardiac pacemakers

1.3.5. DANGER - No admittance for persons fitted with cardiac pacemakers

Description

Warning for persons fitted with cardiac pacemakers because pacemaker malfunction (missed pulses, total failure), pacemaker program interference or even program destruction is to be expected!

Elimination

| | Action | Note/Illustration |
|----|---|--|
| 1. | We recommend that warning signs like the one shown to the right are posted at every entrance to manufacturing shops housing resistance welding equipment. |  <p>No entry for persons with cardiac pacemakers DANGER!</p> <p>xx0500002520</p> |

2 Installation

2.1. Introduction

General

This chapter presents general information, complementing the more specific information in the following chapters.

Sections

The installation chapter is divided in the following sections:

- DressPack lower and/or upper cable package
- DressPack floor cable
- Water and air unit
- IRC5 Spotwelding Cabinet.
- Tipdresser

2 Installation

2.2.1. Overview

2.2 DressPack cable package

2.2.1. Overview

General

Installing, programming and operating the ABB DressPack/SpotPack product program may be a complex task as each application instance is very specific. The product is designed to fit a wide variety of applications, and must be adapted to each in order to maximize life and function.

The generic installation procedure is detailed below.

Limitation of robot movement due to DressPack

When using DressPack upper arm the movements of the robot will be limited.

The position of process cable support axis 6 is important to take in consideration when optimizing the possible movements of the robot.



NOTE!

Maximum movement of axis 5 is about $\pm 118^\circ$.

For more information, please contact Serop Product Support/SEROP/ABB.

E-mail address: serop.product_support@se.abb.com

Effects on armload and performance



NOTE!

The extra weight of the DressPack/SpotPack products will affect the *armload data* and the *performance* of the robot! The effect differs depending on which type of DressPack/SpotPack product. See *DressPack - Armload parameters and LoadId on page 106*.

2.2.2. Installation activities

General

This procedure describes the main activities of fitting the cable package attachments and mounting of the cable packages.

Location

The figure shows the main parts of the process cable package.

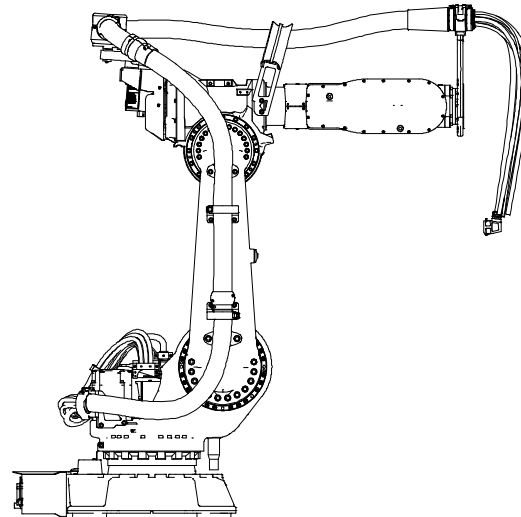

xx0600003150

DressPack lower/upper arm (continuous) cable package - IRBDP MH2 CE and IRBDP SW2 CE

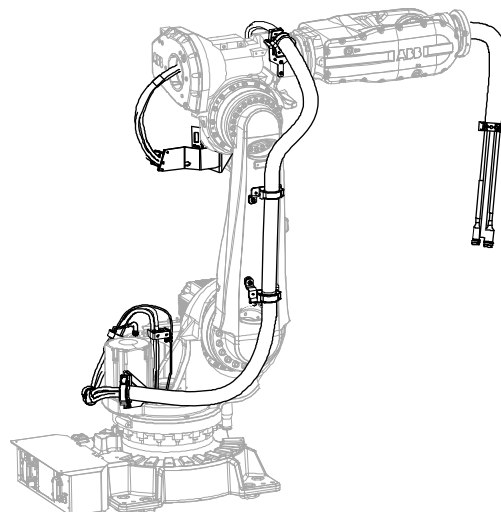

xx0700000617

DressPack lower and upper arm cable package - IRBDP MH3 LE and IRBDP MH3 UE

Continues on next page

2 Installation

2.2.2. Installation activities

Continued

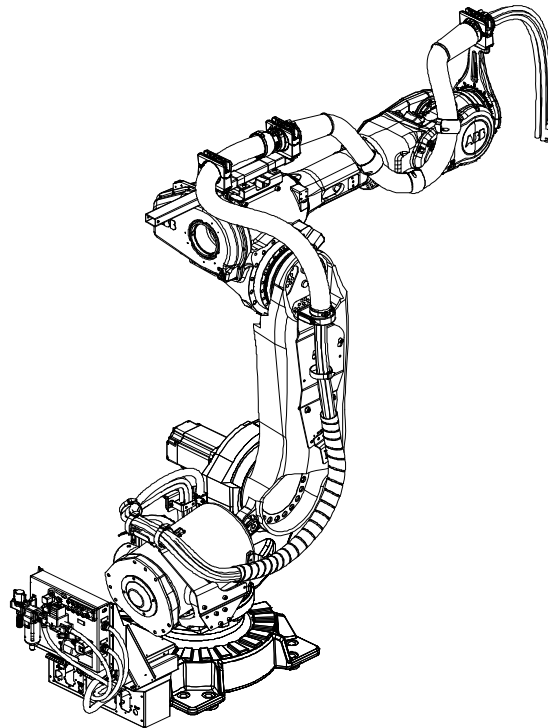

xx080000127

SpotPack Basic cable package IRBDP SW5 CE (The figure shows the cable package fitted on IRB 6640)

Procedures, DressPack continuous cable package

The following procedures are valid for DressPack cable packages *without* division point (continuous).

| | For information about: | See: |
|----|---|---|
| 1. | Fitting the <i>attachments</i> of the continuous cable package. | Described in section <i>Fitting the attachments of the continuous cable package - IRBDP MH 2 CE and IRBDP SW 2 CE on page 48.</i> |
| 2. | Inspecting the lower arm equipment after installation. | Described in section, <i>Inspection, DressPack lower arm on page 91</i> |
| 3. | Inspecting the upper arm equipment after installation. | Described in section, <i>Inspection, DressPack upper arm on page 92</i> |
| 4. | Inspecting the DressPack equipment during programming. | Detailed in section, <i>Inspection during programming and test-running on page 103</i> |
| 5. | Adjustment of the cable package. | Detailed in section <i>Adjustments of - IRBDP MH2 UE and IRBDP SW2 UE on page 96.</i> |

© Copyright 2006-2010 ABB. All rights reserved.

Continues on next page

Continued

Procedures, DressPack cable packages with division point

The following procedures are valid for DressPack cable packages *with* division point.

| | For information about: | See: |
|----|---|--|
| 1. | Fitting the lower arm cable package - IRBDP MH3 LE. | Detailed in section <i>Fitting the lower arm cable package - IRBDP MH 3 LE on page 74.</i> |
| 2. | Fitting the cable package IRBDP MH3 UE. | Detailed in section <i>Fitting the upper arm cable package - IRBDP MH 3 UE on page 81.</i> |
| 3. | Inspect the lower arm equipment after installation. | Detailed in section, <i>Inspection, DressPack lower arm on page 91</i> |
| 4. | Inspect the upper arm equipment after installation. | Detailed in section, <i>Inspection, DressPack upper arm on page 92</i> |
| 5. | Inspection of the DressPack equipment during programming. | Detailed in section, <i>Inspection during programming and test-running on page 103</i> |
| 6. | Adjustment of the upper arm cable package. | Detailed in section, <i>Adjustments of - IRBDP MH2 UE and IRBDP SW2 UE on page 96</i> |

Procedures, SpotPack Basic cable package - IRBDP SW5 CE

The following procedures are valid for SpotPack Basic cable package IRBDP SW5 CE.

| | For information about: | See: |
|----|--|---|
| 1. | Fitting attachments of IRBDP SW5 CE (SpotPack Basic) | Described in section <i>Fitting the attachments of IRBDP SW5 CE (SpotPack Basic) on page 61.</i> |
| 2. | Fitting the cable package IRBDP SW5 CE (SpotPack Basic) | Described in section <i>Fitting the cable package IRBDP SW5 CE (SpotPack Basic) on page 86.</i> |
| 3. | Inspection during programming and test-running | Detailed in section <i>Inspection during programming and test-running on page 103.</i> |
| 4. | Adjustments of the process cable package IRBDP SW5 CE (SpotPack Basic) | Detailed in section <i>Adjustment of the cable package - IRBDP SW5 CE (SpotPack basic) on page 101.</i> |

2 Installation

2.2.3. Fitting the attachments of the continuous cable package - IRBDP MH 2 CE and IRBDP SW 2 CE

2.2.3. Fitting the attachments of the continuous cable package - IRBDP MH 2 CE and IRBDP SW 2 CE

Location of cable package attachments - IRBDP MH 2 CE and IRBDP SW 2 CE

The location of the cable package attachments of IRBDP MH 2 CE and IRBDP SW 2 CE, are shown in the figures below.

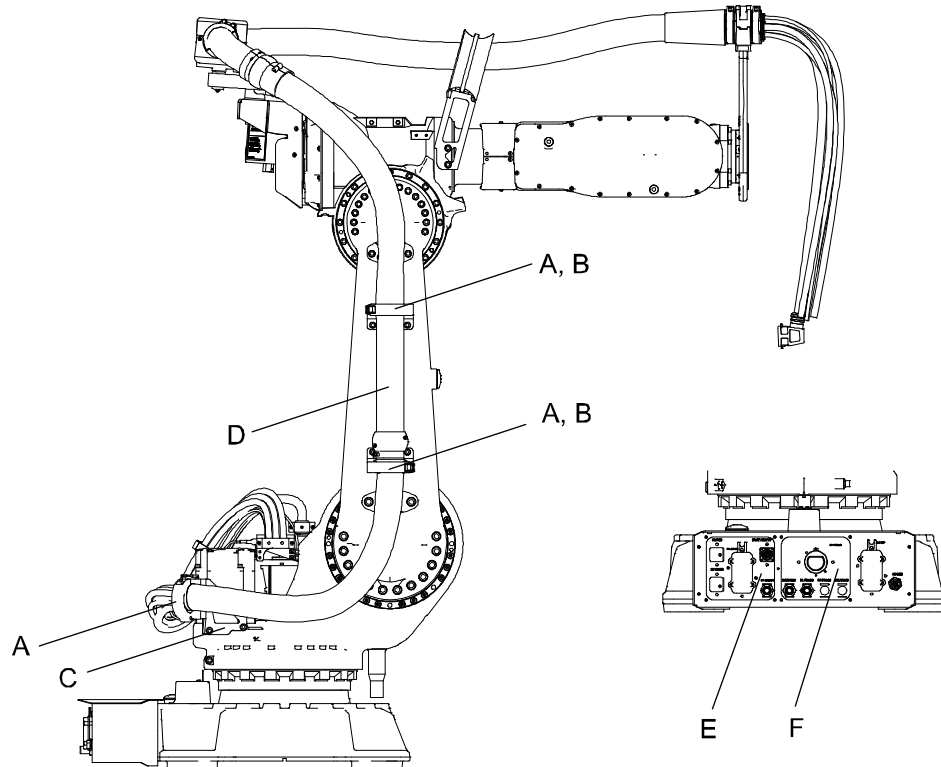

xx0600003148

The lower arm part of cable package IRBDP MH 2 CE and IRBDP SW 2 CE.

| | |
|---|-----------------------|
| A | Gripping clamp |
| B | Bracket, lower arm |
| C | Bracket, back lower |
| D | Process cable package |
| E | Customer plate |
| F | Process plate |

Continued

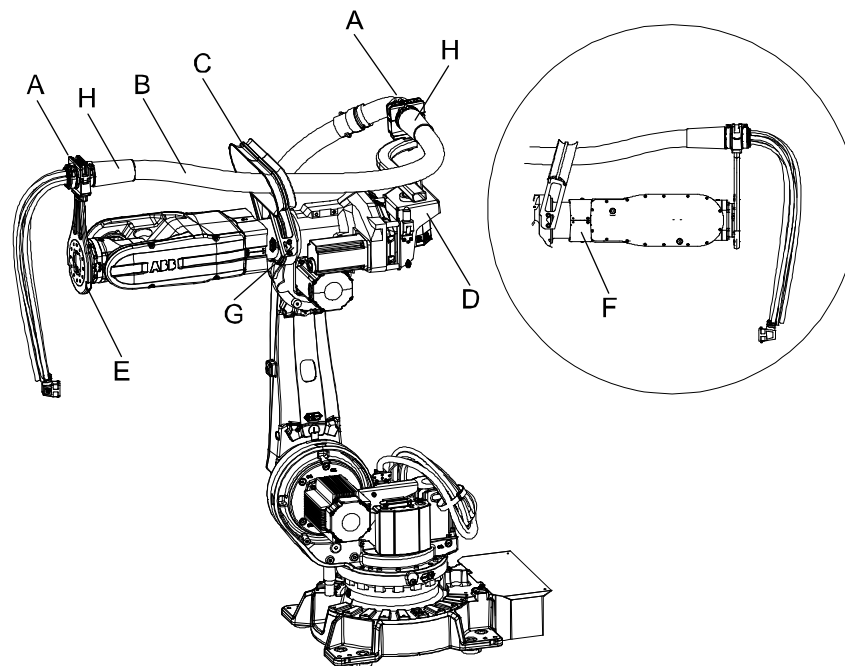

xx0600003149

The upper arm part of the cable package IRBDP MH 2 CE and IRBDP SW 2 CE.

| | |
|---|-------------------------------|
| A | Ball joint housing |
| B | Process cable package |
| C | Hose support |
| D | Tension arm unit |
| E | Process cable support, axis 6 |
| F | Arm protection |
| G | Bracket, hose support |
| H | Hose reinforcement |

Required equipment

The following equipment are required for fitting the cabling package attachments.

| Equipment | Art. no | Note |
|--|-------------|--|
| Locking liquid | 3HAB7116-1 | Loctite 243. For locking the screws. |
| Standard toolkit, DressPack/SpotPack | 3HAC17290-7 | The contents are defined in section Toolkits, DressPack/SpotPack on page 257 . |
| Other tools and procedures may be required. See references to these procedures in the step-by-step instructions below. | | These procedures include references to the tools required. |

Continues on next page

2 Installation

2.2.3. Fitting the attachments of the continuous cable package - IRBDP MH 2 CE and IRBDP SW 2 CE

Continued

Procedure

The following procedure details how to install the lower and upper cable attachments for the DressPack cable package - IRBDP MH 2 CE and IRBDP SW 2 CE.

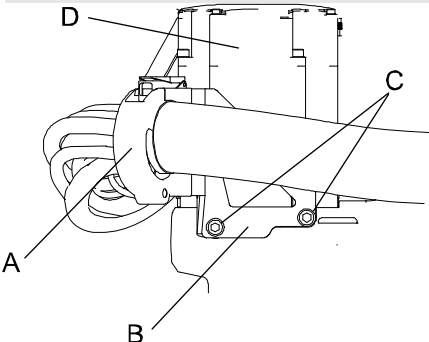
| | Action | Note |
|----|--|---|
| 1. |  <p>DANGER! Turn off all electric power, hydraulic and pneumatic pressure supplies to the robot! For Foundry Prime robots: Do not turn off the air pressure to motors and SMB.</p> | |
| 2. | <p>Fit the <i>gripping clamp</i> to the <i>bracket, back lower</i> and attach it to the frame of the robot. Lock the screws with <i>locking liquid</i>. The screws are supplied with the kit.</p> | <p>The article no. is specified in section Required equipment on page 49.</p>  <p>xx0600003169</p> <p>Parts:</p> <ul style="list-style-type: none"> • A: Gripping clamp • B: Bracket, back lower • C: Attachment screws, bracket M10x16 quality 8.8 • D: Motor, axis 1 |

© Copyright 2006-2010 ABB. All rights reserved.

Continues on next page

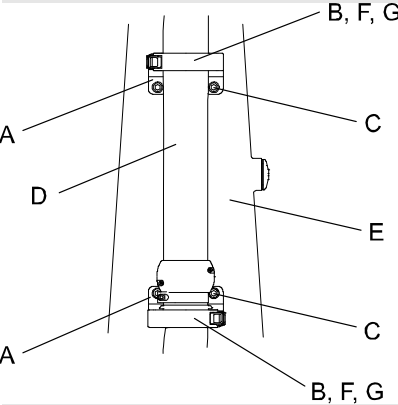
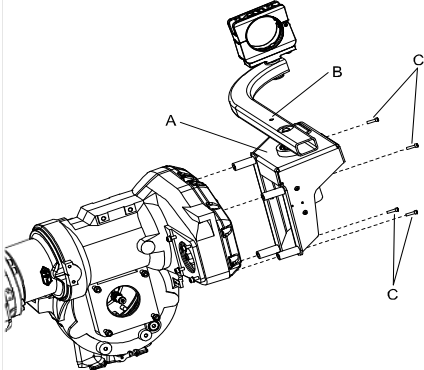

Continued

| | Action | Note |
|--|---|---|
| | <p>3. Fit the <i>bracket, lower arm</i> with its <i>attachment screws</i>.</p> <p>Lock the screws securing the brackets with <i>locking liquid</i>.</p> <p>Then fit the <i>gripping clamp</i> on the bracket with its <i>attachment screws</i> and <i>washer 2 holes</i>. The screws are supplied with the kit.</p> | <p>The article no. is specified in section Required equipment on page 49.</p>  <p>xx0600003170</p> <p>Parts:</p> <ul style="list-style-type: none"> • A: Bracket, lower arm • B: Gripping clamp • C: Attachment screws, bracket M10x16 quality 8.8 (2+2 pcs) • D: Process cable package • E: Lower arm • F: Attachment screws, gripping clamp M8x16 quality 8.8 (2+2 pcs) • G: Washer 2 holes |
| | <p>4. Fit the <i>tension arm unit</i> on the robot arm with its <i>attachment screws</i>.</p> <p>It is possible to use the Ø10 mm hole with a suitable lifting equipment, to lift the tension arm unit.</p> <p>Lock the screws with <i>locking liquid</i>. The screws are supplied with the kit.</p> | <p>The article no. is specified in section Required equipment on page 49.</p>  <p>xx0600003185</p> <p>Parts:</p> <ul style="list-style-type: none"> • A: Tension arm unit • B: Ø10 mm hole • C: Attachment screws M12x80 Gleitmo 12.9 (4 pcs). Tightening torque: 70 Nm. |

2 Installation

2.2.3. Fitting the attachments of the continuous cable package - IRBDP MH 2 CE and IRBDP SW 2 CE

Continued

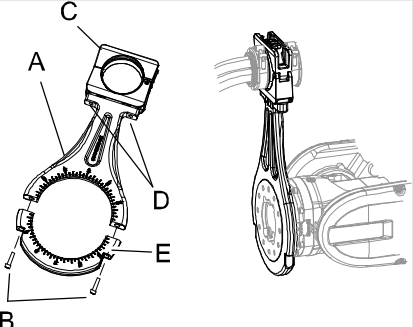
| Action | Note |
|--|--|
| <p>5. Fit the <i>process cable support, axis 6</i> by performing the following steps:</p> <ul style="list-style-type: none">• Remove the lower half of the <i>process cable support axis 6</i> by removing its <i>attachments screws</i>.• Fit the parts from "behind" the robot turning disk.• Make sure the process cable support is turned the right way!• Pull the assembly forwards until it is seated against the rear of the turning disk. <p>Attachment screws are supplied with the kit.</p> <p> NOTE! Make sure the gaps between the clamp and support are equal!</p> <p> NOTE! Lock the M10x40 screws with <i>locking liquid</i> . (No locking liquid on the M12x80 screws)</p> | <p>The article no. is specified in section Required equipment on page 49.</p>  <p>B xx0600003172</p> <p>Parts:</p> <ul style="list-style-type: none">• A: Process cable support, axis 6• B: Attachment screws M12x80 Gleitmo 12.9 (2 pcs). Tightening torque: 70 Nm.• C: Ball joint housing• D: Attachment screws M10x40 quality 8.8 (2 pcs) |

Continued

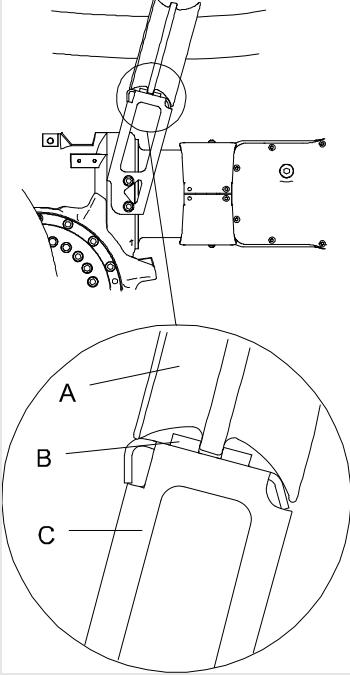
| | Action | Note |
|--|---|---|
| | <p>6. Fit the <i>bracket, hose support</i> to the <i>hose support</i> . Lock the screws with <i>locking liquid</i>.</p> | <p>Art. no. is specified in section Required equipment on page 49.</p>  <p>xx0600003199</p> <p>Parts:</p> <ul style="list-style-type: none"> • A: Hose support • B: Attachment screws M6x16 quality 8.8 (3 pcs) • C: Bracket, hose support |

2 Installation

2.2.3. Fitting the attachments of the continuous cable package - IRBDP MH 2 CE and IRBDP SW 2 CE

Continued

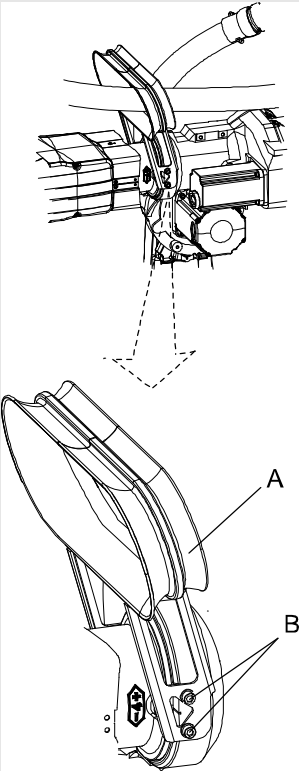
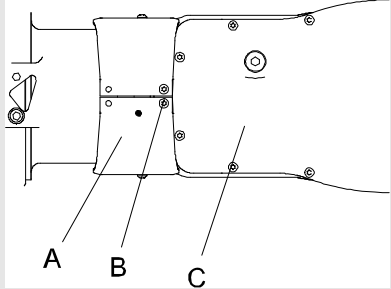
| Action | Note |
|--|---|
| <p>7. Fit the <i>hose support</i> with its bracket fitted, on the upper arm. Lock the screws with <i>locking liquid</i>.</p> | <p>Art. no. is specified in section Required equipment on page 49.</p>  <p>xx0600003200</p> <p>Parts:</p> <ul style="list-style-type: none">• A: Hose support• B: Attachment screws M8x16 quality 8.8 (4 pcs) |
| <p>8. Fit the <i>arm protection</i> with its attachment screws. Lock screws with <i>locking liquid</i>.</p> | <p>Art. no. is specified in section Required equipment on page 49.</p>  <p>xx0600003201</p> <p>Parts:</p> <ul style="list-style-type: none">• A: Arm protection (2 pcs)• B: Attachment screws M6x16 quality 8.8 (6 pcs)• C: Wrist |

© Copyright 2006-2010 ABB. All rights reserved.

2.2.4. Fitting the attachments of the cable package - IRBDP MH 3 LE and IRBDP MH 3 UE

Location of cable package attachments - IRBDP MH 3 LE and IRBDP MH 3 UE

The location of the attachments of cable package IRBDP MH 3 LE and IRBDP MH 3 UE, are shown in the figures below.

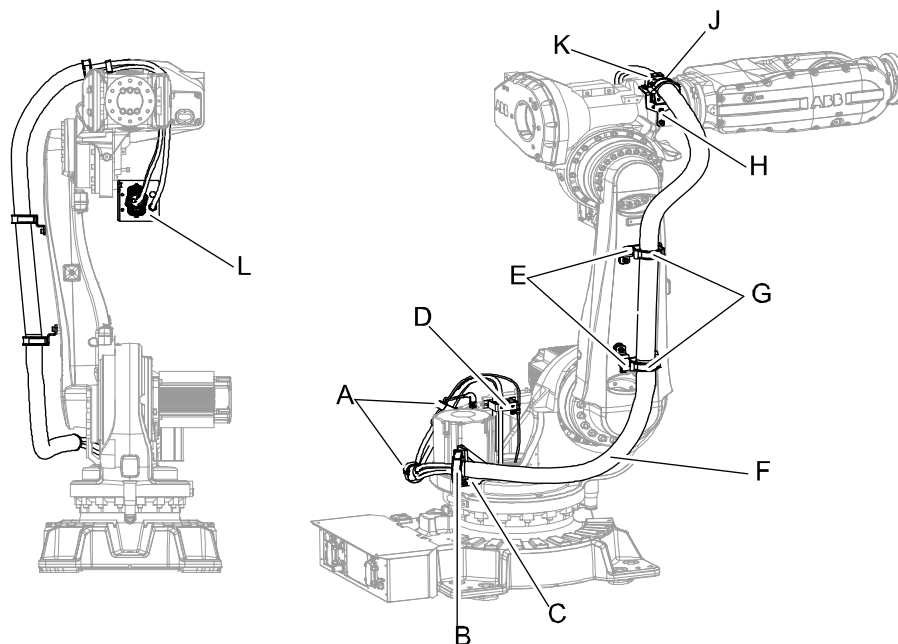

xx0700000579

Attachments of the cable package IRBDP MH 3 LE.

| | |
|---|-------------------------------|
| A | Strap velcro |
| B | Gripping clamp (on frame) |
| C | Bracket back lower |
| D | Metal clamp with rubber clamp |
| E | Bracket lower arm |
| F | Process cable package |
| G | Gripping clamp (on lower arm) |
| H | Bracket for clamp |
| J | Gripping clamp (on upper arm) |
| K | Metal clamp with rubber clamp |
| L | Connection plate ax 3 |

2 Installation

2.2.4. Fitting the attachments of the cable package - IRBDP MH 3 LE and IRBDP MH 3 UE

Continued

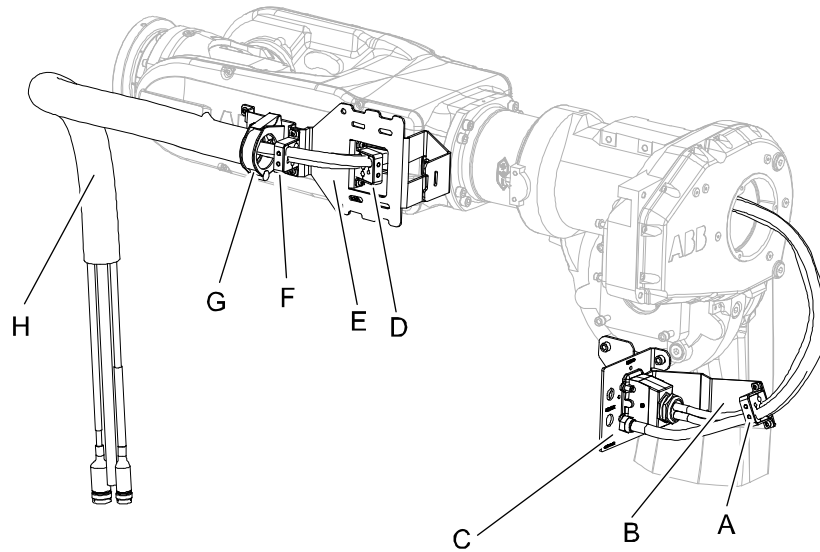

xx070000580

Attachments of the cable package IRBDP MH 3 UE.

| | |
|---|--|
| A | Metal clamp with rubber clamp |
| B | Bracket for metal clamp |
| C | Connection plate ax 3 (delivered with cable package IRBDP MH 3 LE) |
| D | Metal clamp with rubber clamp (right) |
| E | Bracket at wrist |
| F | Metal clamp with rubber clamp (left) |
| G | Gripping clamp with clamp half |
| H | Protection hose |

Required equipment

The following equipment is required for fitting the attachments of cable package IRBDP MH 3 LE and IRBDP MH 3 UE.

| Equipment | Art. no. | Note |
|--|-------------|--|
| Locking liquid | 3HAB7116-1 | Loctite 243 For locking screws. |
| Standard toolkit, DressPack/ SpotPack | 3HAC17290-7 | The contents are defined in section Toolkits, DressPack/SpotPack on page 257 . |
| Other tools and procedures may be required. See references to these procedures in the step-by-step instructions below. | | These procedures include references to the tools required. |

© Copyright 2006-2010 ABB. All rights reserved.

Continues on next page

Continued

Procedure

The following procedure details how to fit the cable package attachments of IRBDP MH 3 LE and IRBDP MH 3 UE.

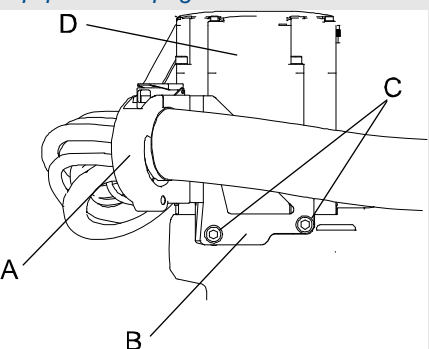
| | Action | Note |
|----|--|---|
| 1. |  <p>DANGER! Turn off all electric power, hydraulic and pneumatic pressure supplies to the robot! For Foundry Prime robots: Do not turn off the air pressure to motors and SMB.</p> | |
| 2. | <p>Fit the <i>gripping clamp</i> to the <i>bracket back lower</i> and attach it to the frame of the robot. Lock screws with <i>locking liquid</i>. Screws are supplied with the kit.</p> | <p>Article no. is specified in section Required equipment on page 56.</p>  <p>xx0600003169</p> <p>Parts:</p> <ul style="list-style-type: none"> • A: Gripping clamp • B: Bracket, back lower • C: Attachment screws, bracket M10x16 quality 8.8 • D: Motor, axis 1 |

2 Installation

2.2.4. Fitting the attachments of the cable package - IRBDP MH 3 LE and IRBDP MH 3 UE

Continued

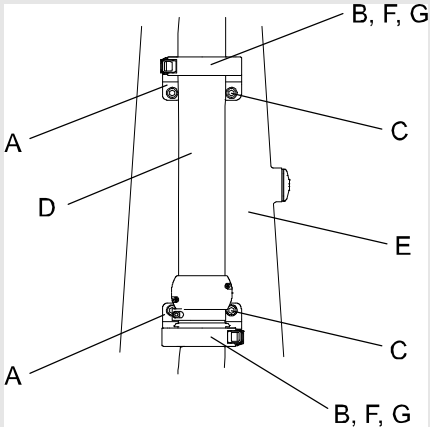
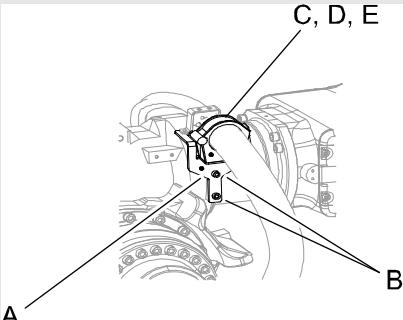
| Action | Note |
|---|--|
| <p>3. Fit the <i>bracket lower arm</i> with its attachment screws.</p> <p>Lock screws securing the bracket lower arm with <i>locking liquid</i>.</p> <p>Then fit the <i>gripping clamp</i> on the bracket lower arm with its attachment screws and the <i>washer 2 holes</i>.</p> <p>Lock screws securing the gripping clamp with <i>locking liquid</i>.</p> <p>Screws are supplied with the kit.</p> | <p>Article no. is specified in section Required equipment on page 56.</p>  <p>xx0600003170</p> <p>Parts:</p> <ul style="list-style-type: none"> • A: Bracket, lower arm • B: Gripping clamp • C: Attachment screws, bracket M10x16 quality (2+2 pcs) • D: Process cable package • E: Lower arm • F: Attachment screws, gripping clamp M8x16 quality 8.8-A2F (2+2 pcs) • G: Washer 2 holes (2 pcs) |
| <p>4. Fit the <i>bracket for clamp</i> with its attachments screws.</p> <p>Lock screws securing the bracket for clamp with <i>locking liquid</i>.</p> <p>Then fit the <i>gripping clamp</i> on the bracket with its attachment screws and the <i>washer 2 holes</i>.</p> <p>Lock screws securing the gripping clamp with <i>locking liquid</i>.</p> <p>Screws are supplied with the kit.</p> | <p>Article no. is specified in section Required equipment on page 56.</p>  <p>xx0700000584</p> <p>Parts:</p> <ul style="list-style-type: none"> • A: Bracket for clamp • B: Attachment screws M8x16 quality 8.8-A2F (2 pcs) • C: Gripping clamp • D: Attachment screws M8x16 quality 8.8-A2F • E: Washer 2 holes |

© Copyright 2006-2010 ABB. All rights reserved.

Continues on next page

2.2.4. Fitting the attachments of the cable package - IRBDP MH 3 LE and IRBDP MH 3 UE

Continued

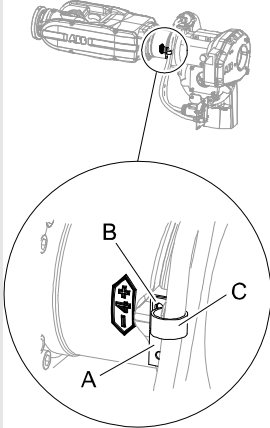
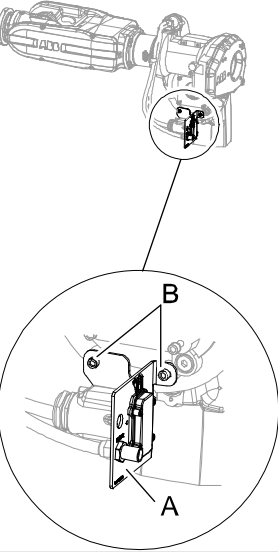
| | Action | Note |
|--|---|--|
| | <p>5. Fit the <i>cable fixing bracket</i> with its attachments screws. Lock screws securing the cable fixing bracket with <i>locking liquid</i>. Screws are supplied with the kit.</p> | <p>Article no. is specified in section Required equipment on page 56.</p>  <p>xx0700000585</p> <p>Parts:</p> <ul style="list-style-type: none"> • A: Cable fixing bracket • B: Attachment screws M 8x16 quality 8.8-A2F (2 pcs) • C: Velcro strap |
| | <p>6. Fit the <i>connection plate</i> to axis 3 with its attachment screws. Lock screws securing the connection plate with <i>locking liquid</i>. Screws are supplied with the kit.</p> | <p>Article no. is specified in section Required equipment on page 56.</p>  <p>xx0700000588</p> <p>Parts:</p> <ul style="list-style-type: none"> • A: Connection plate • B: Attachment screws M10x16 quality 8.8-A3F (2 pcs) |

2 Installation

2.2.4. Fitting the attachments of the cable package - IRBDP MH 3 LE and IRBDP MH 3 UE

Continued

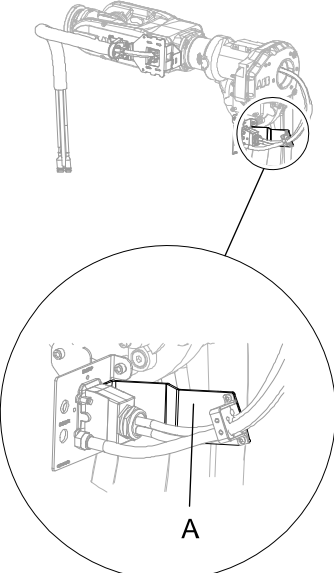
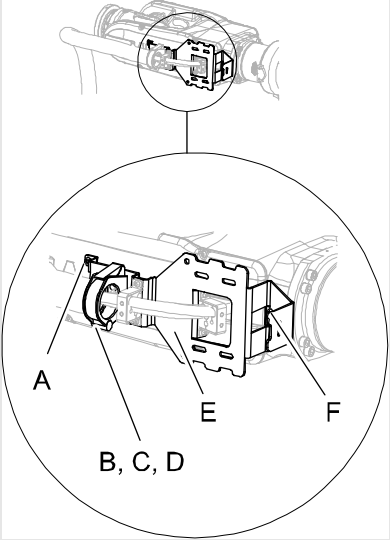
| Action | Note |
|--|--|
| <p>7. Fit the <i>bracket for metal clamp</i> to the connection plate with its attachment screws M8x25 quality 8.8-A2F (2 pcs) and nuts (M8).</p> |  <p>xx0700000592</p> <p>Parts:</p> <ul style="list-style-type: none"> • A: Bracket for metal clamp |
| <p>8. Fit <i>bracket at wrist</i> with its attachment screws. Lock screws securing the bracket at wrist with <i>locking liquid</i>. Then fit the <i>gripping clamp</i> on the bracket with its attachment screws and the washer 2 holes. Lock screws with <i>locking liquid</i>. Screws are supplied with the kit.</p> | <p>Article no. is specified in section Required equipment on page 56.</p>  <p>xx0700000594</p> <p>Parts:</p> <ul style="list-style-type: none"> • A: Attachment screws, bracket M6x16 quality 8.8-A2F (2 pcs) • B: Gripping clamp • C: Attachment screws, gripping clamp M8x16 quality 8.8-A2F (2 pcs) • D: Washer 2 holes • E: Bracket at wrist • F: Attachment screws, bracket M6x12 quality 8.8-A2F (2 pcs) |

© Copyright 2006-2010 ABB. All rights reserved.

2.2.5. Fitting the attachments of IRBDP SW5 CE (SpotPack Basic)

Location of the attachments

The location of the attachments of IRBDP SW5 CE (SpotPack Basic) is shown in the figure.

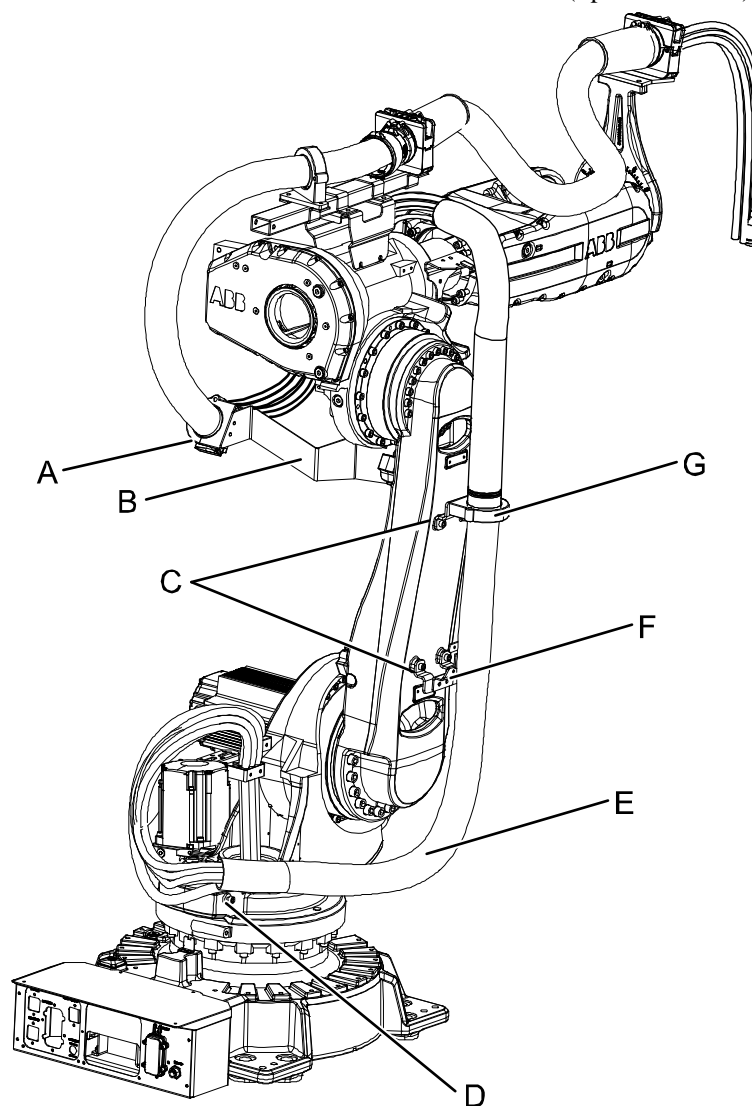

xx080000110

| | |
|---|---|
| A | Gripping clamp (axis 3 clamp mount) |
| B | Axis 3 clamp mount (fitted on Axis 3 cable bracket) |
| C | Lower brackets |
| D | Bracket back lower + Spiral hose clamp |
| E | Spiral hose |
| F | Spiral hose clamp |
| G | Gripping clamp (lower bracket) |

2 Installation

2.2.5. Fitting the attachments of IRBDP SW5 CE (SpotPack Basic)

Continued

Location of upper attachments

The location of the upper attachments of the cable package IRBDP SW5 CE (SpotPack Basic) are shown in the figure below.

The figure below shows the robot model IRB 66X0.

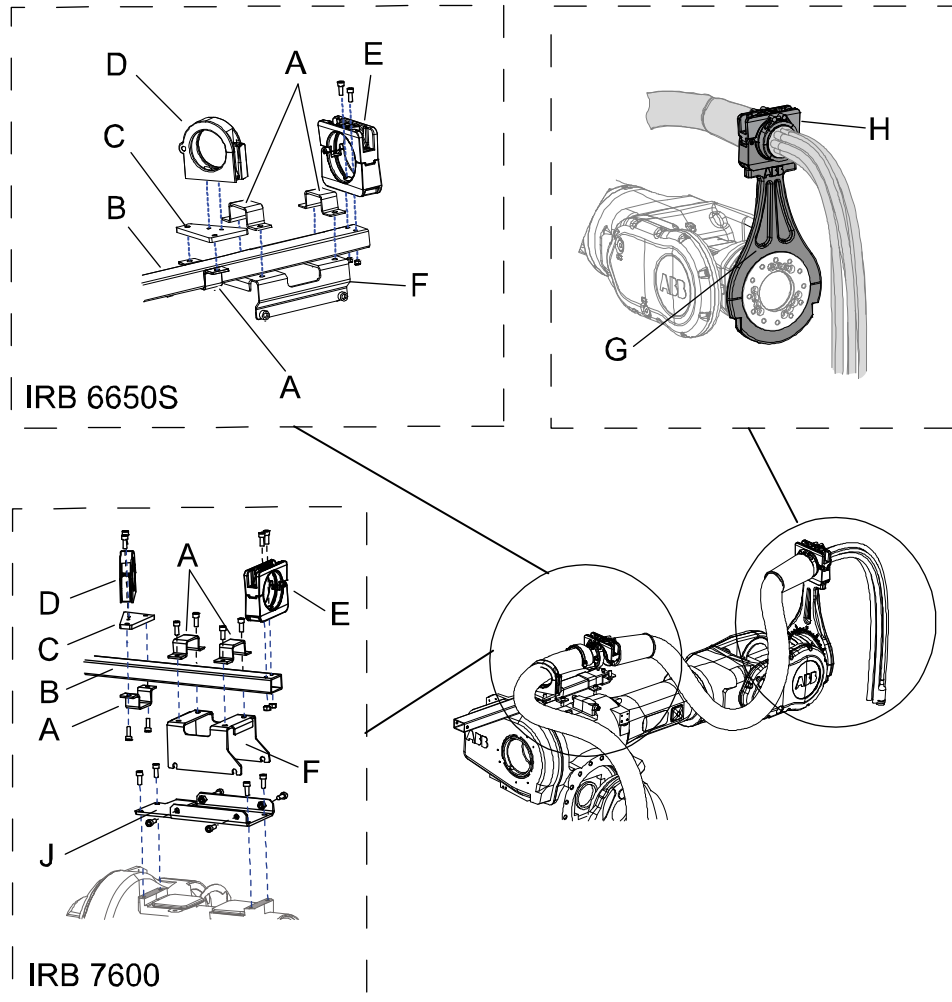

xx080000074

| | |
|---|---|
| A | Bracket (3 pcs) |
| B | Adjustable bracket |
| C | Angled clamp bracket |
| D | Gripping clamp |
| E | Ball joint housing (adjustable bracket) |
| F | Axis 3 bracket |
| G | Process cable support axis 6 |
| H | Ball joint housing (harness support axis 6) |

© Copyright 2006-2010 ABB. All rights reserved.

Continues on next page

Required equipment

| Equipment | Part. no. | Note |
|--|-------------|--|
| Locking liquid | 3HAB7116-1 | Loctite 243 For locking screws. |
| Standard toolkit DressPack/ SpotPack | 3HAC17290-7 | The contents are defined in section Toolkits, DressPack/SpotPack on page 257 . |
| Other tools and procedures may be required. See references to these procedures in the step-by-step instructions below. | | These procedures include references to the tools required. |

Fitting cable attachments - lower end

This procedure describes how to install the attachments at the lower end of the cable package (SpotPack basic).

| | Action | Note |
|----|---|--|
| 1. |  DANGER! Turn off all electric power, hydraulic and pneumatic pressure supplies to the robot! For Foundry Prime robots: Do not turn off the air pressure to motors and SMB. | |
| 2. | Fit the <i>bracket back lower</i> to the frame with its attachment screws. Also fit the <i>spiral hose clamp</i> on the bracket back lower, Lock screws with <i>locking liquid</i> . | Locking liquid is specified in Required equipment on page 63 . Shown in the figure Location of the attachments on page 61 . |
| 3. | Fit the <i>lower brackets</i> with its <i>attachment screws</i> . Lock screws securing the lower brackets lower arm with <i>locking liquid</i> . | Locking liquid is specified in Required equipment on page 63 . Shown in the figure Location of the attachments on page 61 . |
| 4. | Fit the <i>spiral hose clamp</i> on the bottom lower bracket. | Shown in the figure Location of the attachments on page 61 . |
| 5. | Fit a <i>gripping clamp</i> on the top lower bracket with its <i>attachment screws</i> and <i>washer 2 holes</i> . Lock screws with <i>locking liquid</i> . | Locking liquid is specified in Required equipment on page 63 . |
| 6. | Fit the <i>axis 3 clamp mount</i> on the <i>axis 3 cable bracket</i> with its attachment screws and nuts. | Shown in the figure Location of the attachments on page 61 . |
| 7. | Fit a <i>gripping clamp</i> on the axis 3 clamp mount with its attachment screws and washer 2 holes. | Shown in the figure Location of the attachments on page 61 . |

Continues on next page

2 Installation

2.2.5. Fitting the attachments of IRBDP SW5 CE (SpotPack Basic)



Continued

Fitting cable attachments - upper end

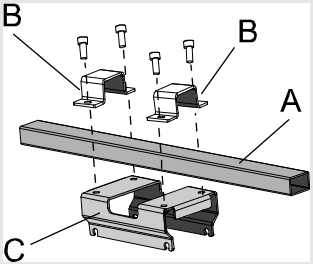
This procedure describes how to install the attachments at the upper end of the cable package (SpotPack basic).

| | Action | Note |
|----|---|---|
| 1. |  DANGER! Turn off all electric power, hydraulic and pneumatic pressure supplies to the robot! For Foundry Prime robots: Do not turn off the air pressure to motors and SMB. | |
| 2. | Fit the <i>adjustable bracket</i> to the <i>axis 3 bracket</i> with its <i>brackets</i> and attachment screws. Lock screws with <i>locking liquid</i> . | Locking liquid is specified in Required equipment on page 63 .  xx080000076 Parts: <ul style="list-style-type: none">• A: Adjustable bracket• B: Bracket• C: Axis 3 bracket |

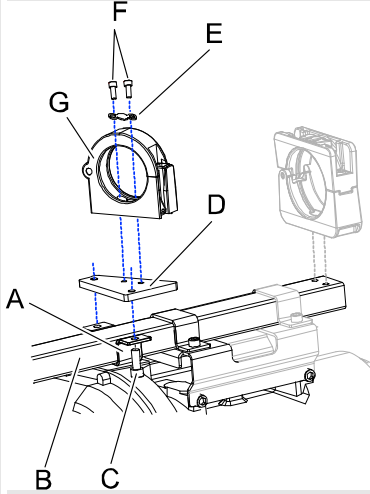
Continued

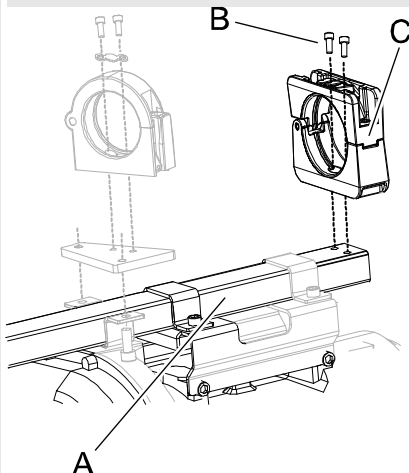
| Action | Note |
|---|--|
| <p>3. Fit the <i>gripping clamp</i> to the <i>angled clamp bracket</i> with its <i>attachment screws</i> and <i>washer 2 holes</i>. Lock screws with <i>locking liquid</i>. Then fit the angled clamp bracket with the gripping clamp already fitted on the <i>adjustable bracket</i> with the <i>bracket</i> and its <i>attachment screws</i>.</p> <p> NOTE! Do not secure the attachment screws (M10x25) at this point! It must still be possible to move the gripping clamp back and forth on the adjustable bracket. Adjustment of the gripping clamp is detailed in section Adjustment of the cable package - IRBDP SW5 CE (SpotPack basic) on page 101.</p> | <p>Locking liquid is specified in Required equipment on page 63.</p>  <p>xx0800000107</p> <p>Parts:</p> <ul style="list-style-type: none"> • A: Bracket • B: Adjustable bracket • C: Attachment screw M10x25 quality 8.8-A3F (2 pcs) • D: Angled clamp bracket • E: Washer 2 holes • F: Attachment screw M8x16 quality 8.8_A2F (2 pcs) • G: Gripping clamp |
| <p>4. Fit the <i>ball joint housing</i> to the <i>adjustable bracket</i> with the <i>bracket</i> and its <i>attachment screws</i> and <i>washer 2 holes</i>.</p> <p> NOTE! Do not secure the attachment screws (M10x25) at this point! It must still be possible to move the gripping clamp back and forth on the adjustable bracket. Adjustment of the gripping clamp is detailed in section Adjustment of the cable package - IRBDP SW5 CE (SpotPack basic) on page 101.</p> |  <p>xx0800000108</p> <p>Parts:</p> <ul style="list-style-type: none"> • A: Adjustable bracket • B: Attachment screw M10x25 quality 8.8-A3F (2 pcs) • C: Ball joint housing |
| <p>5. Fit the <i>spiral hose bracket</i> to the upper arm.</p> | |

Continues on next page

2 Installation

2.2.5. Fitting the attachments of IRBDP SW5 CE (SpotPack Basic)

Continued

| | Action | Note |
|----|--|--|
| 6. | Fit the <i>harness support axis 6</i> to the turning disk with its attachment screws. Lock screws with <i>locking liquid</i> . | Shown in the figure <i>Location of upper attachments on page 62</i> . Locking liquid is specified in <i>Required equipment on page 63</i> . |
| 7. | Fit the <i>ball joint housing</i> the harness support axis 6 with its attachment screws. Lock screws with <i>locking liquid</i> . | Shown in the figure <i>Location of upper attachments on page 62</i> . Locking liquid is specified in <i>Required equipment on page 63</i> . |

2.2.6. Fitting the cable package IRBDP SW2 CE IRBDP MH2 CEand

Location of cable package - IRBDP MH2 CEandIRBDP SW2 CE

The cable package, IRBDP MH2 CEandIRBDP SW2 CE consists of the parts shown in the illustration below.

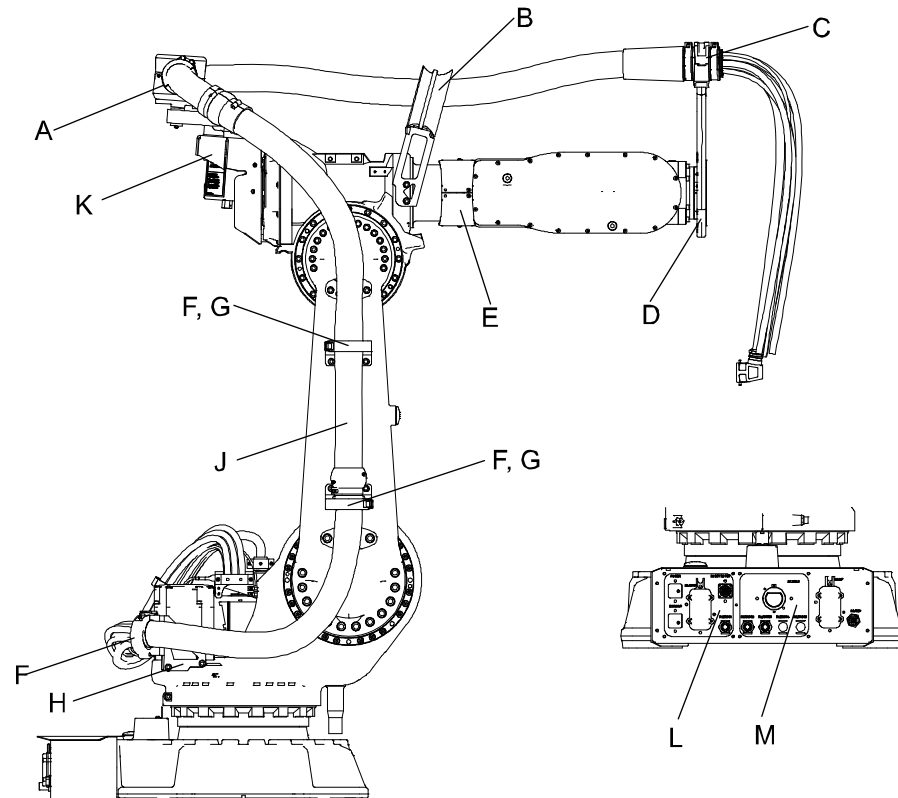

xx0600003151

| | |
|---|--|
| A | Ball joint housing, back end |
| B | Hose support |
| C | Ball joint housing, front end |
| D | Process cable support axis 6, complete |
| E | Arm protection |
| F | Gripping clamp |
| G | Bracket, lower arm |
| H | Bracket, back lower |
| J | Process cable package |
| K | Tension arm unit |
| L | Customer plate |
| M | Process plate |

2 Installation

2.2.6. Fitting the cable package IRBDP SW2 CE IRBDP MH2 CEand

Continued



Required equipment

The following equipment are required for installation of the cable package IRBDP MH 2 CEandIRBDP SW 2 CE.

| Equipment | Art. no. | Note |
|--|----------------------------------|---|
| Process cable package IRBDP SW2 CE | | A number of versions are available. See <i>Spare Parts</i> chapter. |
| Process cable package IRBDP MH2 CE | | A number of versions are available. See <i>Spare parts</i> chapter. |
| Locking liquid | 3HAB7116-1 | Loctite 243 For locking the gripping clamps. |
| Standard toolkit, DressPack/SpotPack | 3HAC17290-7 | The contents are defined in section <i>Toolkits, DressPack/SpotPack on page 257</i> . |
| Other tools and procedures may be required. See references to these procedures in the step-by-step instructions below. | | These procedures include references to the tools required. |
| Circuit diagram | 3HAC026136-001 3HAC026208-001 | DressPack SpotPack |

Procedure

Use this procedure to fit the cable package IRBDP MH2 CEandIRBDP SW2 CE.

| Action | Note |
|--|------|
| 1.  DANGER! Turn off all electric power, hydraulic and pneumatic pressure supplies to the robot! For Foundry Prime robots: Do not turn off the air pressure to motors and SMB. | |
| 2.  CAUTION! The cable package is sensitive to mechanical damage. They must be handled with care, especially the connectors, in order to avoid damaging them. | |

© Copyright 2006-2010 ABB. All rights reserved.

Continues on next page

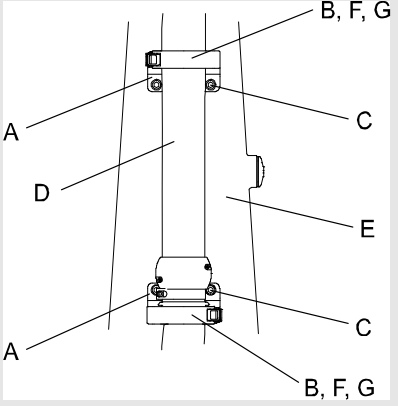
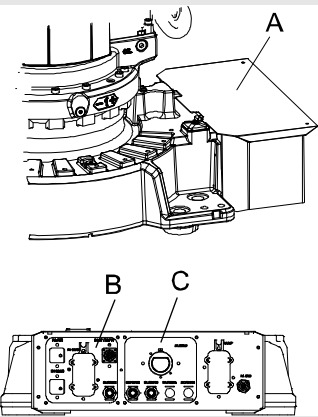

Continued

| | Action | Note |
|--|---|---|
| | <p>3. Secure the cable package to the <i>upper</i> and <i>lower gripping clamps</i> on the lower arm.</p> |  <p>xx0600003170</p> <ul style="list-style-type: none"> • A: Bracket lower arm • B: Gripping clamp • C: Attachment screws, bracket M10x16 quality (2+2 pcs) • D: Process cable package • E: Lower arm • F: Attachment screw, gripping clamp M8x18 quality 8.8 (2+2 pcs) • G: Washer 2 holes |
| | <p>4. Remove the <i>top cover plate</i> in the back of the robot base.</p> |  <p>xx0600003174</p> <p>Parts:</p> <ul style="list-style-type: none"> • A: Top cover plate • B: Customer plate • C: Process plate |

2 Installation

2.2.6. Fitting the cable package IRBDP SW2 CE IRBDP MH2 CE and IRBDP SW2 CE

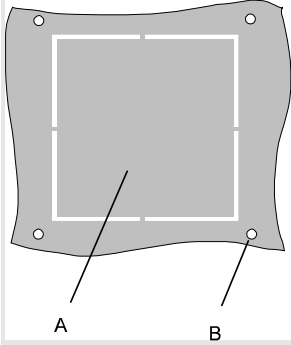
Continued

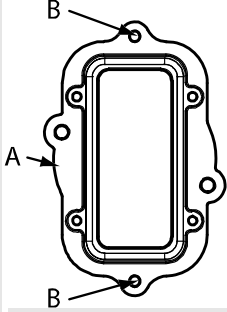
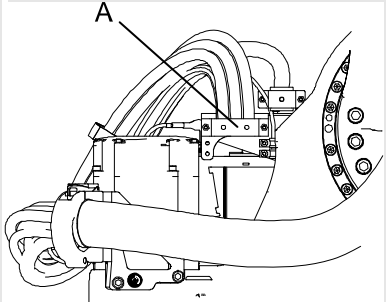
| Action | Note |
|--|--|
| <p>5. Remove the part of the backplate where <i>process</i> and <i>customer plates</i> are supposed to be fitted. Hit the removable part with a plastic mallet or similar without damaging other parts of the backplate.</p> <p>Fit process and customer plates.</p> | <p>Shown in the figure Location of cable package - IRBDP MH2 CE and IRBDP SW2 CE on page 67.</p>  <p>xx070000404</p> <p>Parts:</p> <ul style="list-style-type: none"> A: Removable part of backplate B: Holes for attachment screws  <p>NOTE!</p> <p>Only needed when the DressPack cable package is fitted for the first time.</p> |
| <p>6. Fit the <i>adapter complete</i> to the customer plate with its two <i>attachment screws</i>. Screws are supplied with the kit.</p> |  <p>xx030000195</p> <p>Parts:</p> <ul style="list-style-type: none"> A: Adapter complete B: Attachment screws M6x16 quality 8.8-A2F (2 pcs) |
| <p>7. Run the cables down through the center hole of gearbox axis 1 in the following order:</p> <ul style="list-style-type: none"> Signal cables Hoses, slightly to the right of the signal cables. <p>Check:</p> <ul style="list-style-type: none"> Check that signal cables and hoses do not end up between the motor cables! Check that cables and hoses do not cross each other. |  <p>xx0600003188</p> <ul style="list-style-type: none"> A: Cable holder bracket axis 1 |

© Copyright 2006-2010 ABB. All rights reserved.

Continues on next page

Continued

| | Action | Note |
|-----|---|---|
| 8. | <p>Attach the cable holder bracket with its attachment screws M10x16 quality 8.8 (3 pcs). Lock the screws with <i>locking liquid</i>. Screws are supplied with the kit.</p> | <p>Art. no. is specified in section Required equipment on page 68.</p> |
| 9. | <p>Spotwelding applications only: Run the <i>weld power cable</i>, slightly to the right of the signal cable and hoses in order to facilitate the connecting of cables in the robot base.</p> | <p>Check that the weld power cable do not end up between other cables and hoses.</p> |
| 10. | <p>Spotwelding applications only: Fit the weld power cable to the rear of the <i>process plate</i>, with two <i>attachment screws</i> using the <i>weld connector bracket</i>. Do not tighten the attachment screws at this point. Screws are supplied with the kit.</p> | <div data-bbox="1008 689 1380 1019" data-label="Image"> </div> <p>xx0300000196</p> <p>Parts (as seen from above):</p> <ul style="list-style-type: none"> • A: Weld power cable (behind process plate) • B: Weld connector bracket • C: Process plate • D: Screw holes in process plate • E: Attachment screws M6x30 quality 8.8-A2F (2 pcs) • F: Guide pins on weld connector bracket |
| 11. | <p>Fit the connectors to the <i>customer plate</i> and <i>process plate</i> previously fitted to the <i>connection plate</i>, base. Screws are supplied with the kit.</p> | <p>Shown in the figure in section Location of cable package - IRBDP MH2 CEandIRBDP SW2 CE on page 67. Recheck all cables and hoses for straining or twisting. Reroute if required! Screw dimension: M6x20</p> |
| 12. | <div data-bbox="523 1594 598 1675" data-label="Image"> </div> <p>TIP! In order to get the weld power cable fitted in the right position on the plate customer, first connect the floor weld cable to the weld power cable and use it as a guide. Before tightening the weld power attachment screws, make sure that the cable connector is evenly positioned in the hole of the process plate. Tighten the weld power cable attachment screws.</p> | <p>The weld power attachments screws are shown in figure above!</p> |

Continues on next page

2 Installation

2.2.6. Fitting the cable package IRBDP SW2 CE IRBDP MH2 CE and

Continued

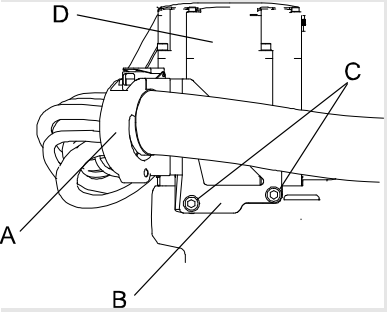
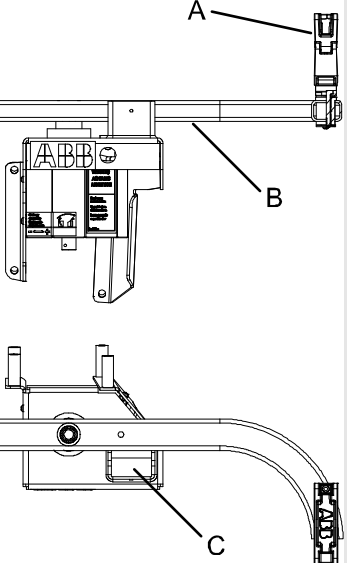
| | Action | Note |
|-----|---|---|
| 13. | Secure the hoses and cables to the <i>gripping clamp, frame</i> . |  <p>xx0600003169</p> <ul style="list-style-type: none"> • A: Gripping clamp, frame • B: Bracket, back lower • C: Attachment screws, bracket M10x16 quality 8.8 (2 pcs) • D: Motor, axis 1 |
| 14. | Run the front end of the process cable package through the <i>hose support</i> . | Shown in the figure in section Location of cable package - IRBDP MH2 CE and IRBDP SW2 CE on page 67. |
| 15. | Straighten the cable package out and place it in the <i>ball joint housing</i> on the <i>tension arm</i> . Secure it. The figure shows the position of the tension unit. |  <p>xx0600003187</p> <p>Parts:</p> <ul style="list-style-type: none"> • A: Ball joint housing • B: Tension arm unit • C: Damper |

© Copyright 2006-2010 ABB. All rights reserved.

Continues on next page

Continued

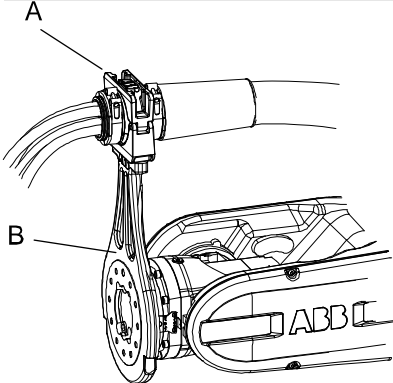
| | Action | Note |
|-----|--|---|
| 16. | Place the front end of the cable package in the ball joint housing on the process cable support axis 6, and secure it. | <p>Shown in the figure below:</p>  <p>xx0600003173</p> <ul style="list-style-type: none"> • A: Ball joint housing • B: Process cable support, axis 6 |

2 Installation

2.2.7. Fitting the lower arm cable package - IRBDP MH 3 LE

2.2.7. Fitting the lower arm cable package - IRBDP MH 3 LE

Location of the lower arm cable package - IRBDP MH 3 LE

The location of cable package IRBDP MH 3 LE, is shown in the figure below.

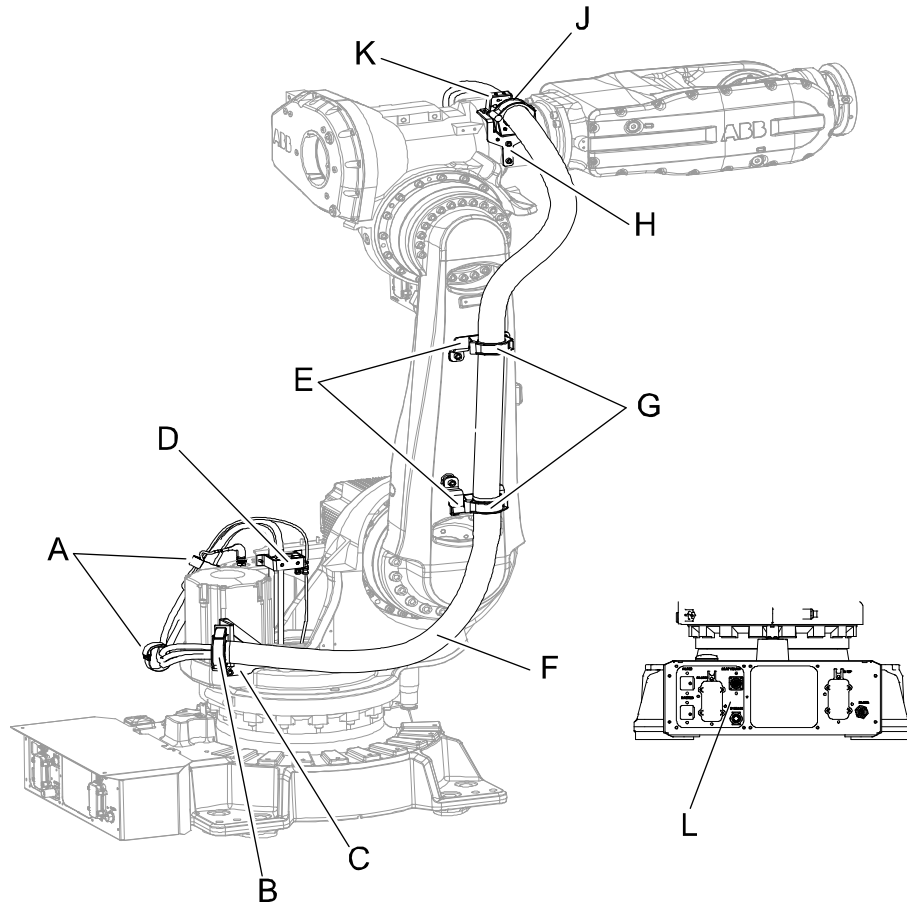

xx070000596

| | |
|---|---------------------------------|
| A | Strap velcro |
| B | Gripping clamp (on frame) |
| C | Bracket back lower |
| D | Metal clamp with rubber clamp |
| E | Bracket lower arm |
| F | Protection hose (Cable package) |
| G | Gripping clamp (on lower arm) |
| H | Bracket for clamp |
| J | Gripping clamp (on upper arm) |
| K | Metal clamp with rubber clamp |
| L | Customer plate |

© Copyright 2006-2010 ABB. All rights reserved.

Continues on next page

Required equipment



The following equipment is required for fitting the cable package IRBDP MH 3 LE.

| Equipment | Art. no. | Note |
|--|-------------|--|
| Locking liquid | 3HAB7116-1 | Loctite 243 For locking screws. |
| Standard toolkit, DressPack/SpotPack | 3HAC17290-7 | The contents are defined in section Toolkits, DressPack/SpotPack on page 257 . |
| Other tools and procedures may be required. See references to these procedures in the step-by-step instructions below. | | These procedures include references to the tools required. |

Procedure

This procedure details how to fit the cable package IRBDP MH 3 LE.

How to fit cable package IRBDP MH 3 UE is detailed in section [Fitting the upper arm cable package - IRBDP MH 3 UE on page 81](#).

| | Action | Note |
|----|---|------|
| 1. |  DANGER! Turn off all electric power, hydraulic and pneumatic pressure supplies to the robot! For Foundry Prime robots: Do not turn off the air pressure to motors and SMB. | |
| 2. |  CAUTION! The cable package is sensitive to mechanical damage. They must be handled with care, especially the connectors, in order to avoid damaging them. | |

2 Installation

2.2.7. Fitting the lower arm cable package - IRBDP MH 3 LE

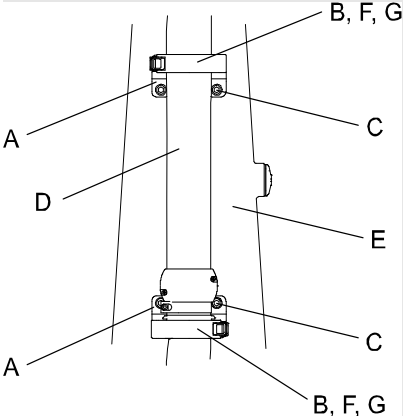
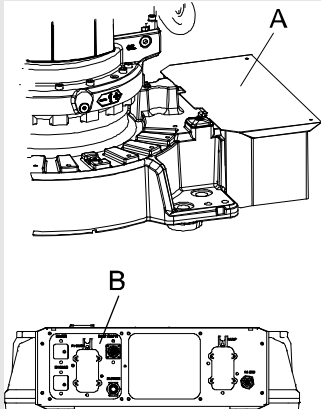

Continued

| | Action | Note |
|--|---|---|
| | <p>3. Secure the cable package to the <i>upper</i> and <i>lower gripping clamps</i> on the lower arm.</p> | <p>Article no. is specified in section Required equipment on page 75.</p>  <p>xx060003170</p> <p>Parts:</p> <ul style="list-style-type: none"> • A: Bracket, lower arm • B: Gripping clamps, upper and lower • C: Attachment screws, bracket M10x16 quality 8.8-A3F (2+2 pcs) • Process cable package • E: Lower arm • F: Attachment screw, gripping clamp M8x18 quality 8.8-A2F (2+2 pcs) • G: Washer 2 holes |
| | <p>4. Remove the <i>top cover plate</i> in the back of the robot base.</p> |  <p>xx070000618</p> <p>Parts:</p> <ul style="list-style-type: none"> • A: Top cover plate • B: Customer plate |

© Copyright 2006-2010 ABB. All rights reserved.

Continues on next page

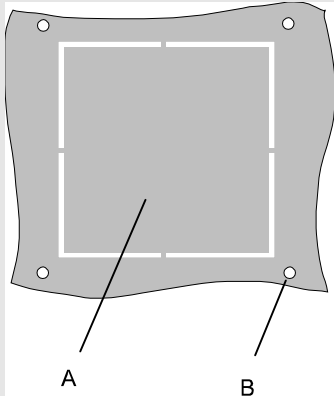
Continued

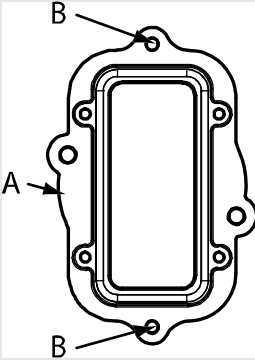
| Action | Note |
|--|---|
| <p>5. Remove the part of the backplate where the <i>customer plate</i> is supposed to be fitted. Hit the removable part with a plastic mallet or similar without damaging other parts of the backplate. Fit process and customer plates.</p> | <p>Shown in the figure Location of the lower arm cable package - IRBDP MH 3 LE on page 74.</p>  <p>xx0700000404</p> <p>Parts:</p> <ul style="list-style-type: none"> • A: Removable part of backplate • B: Holes for attachment screws  <p>NOTE! Only needed when the DressPack cable package is fitted for the first time.</p> |
| <p>6. Fit the <i>adapter complete</i> to the customer plate with its two <i>attachment screws</i>. Screws are supplied with the kit.</p> |  <p>xx0300000195</p> <p>Parts:</p> <ul style="list-style-type: none"> • A: Adapter complete • B: Attachment screws M6x16 quality 8.8-A2F (2 pcs) |

2 Installation

2.2.7. Fitting the lower arm cable package - IRBDP MH 3 LE

Continued

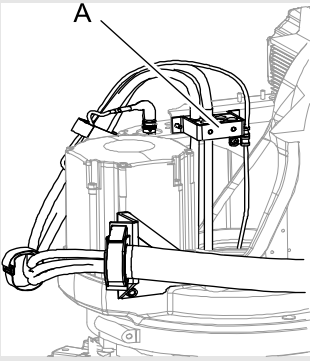
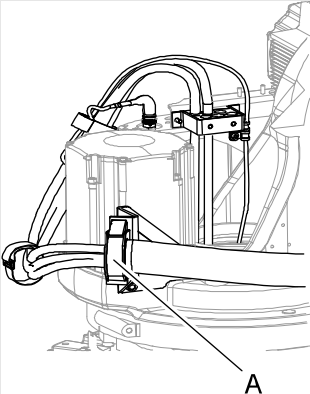
| | Action | Note |
|-----|---|---|
| 7. | <p>Run the cables down through the centrum hole of gearbox axis 1 in the following order:</p> <ul style="list-style-type: none"> • Signal cable • Hoses, slightly to the right of the signal cable <p>Check:</p> <ul style="list-style-type: none"> • that signal cable and hoses doesn't end up between the motor cables • that cables and hoses aren't crossing each other. |  <p>xx0700000598</p> <p>Parts:</p> <ul style="list-style-type: none"> • A: Cable holder bracket |
| 8. | <p>Attach the <i>cable holder bracket</i> with its attachment screws M10x16 quality 8.8-A3F (3 pcs).</p> <p>Lock the screws with <i>locking liquid</i>.</p> <p>Screws are supplied with the kit.</p> | <p>See figure above!</p> <p>Art. no. is specified in section Required equipment on page 75.</p> |
| 9. | <p>Fit the connectors to the <i>customer plate</i>, previously fitted to the <i>connection plate, base</i>.</p> <p>Screws are supplied with the kit.</p> | <p>Shown in the figure in section Location of the lower arm cable package - IRBDP MH 3 LE on page 74.</p> <p>Recheck all cables and hoses for straining or twisting. Reroute if required!</p> <p>Screw dimension: M6x20</p> |
| 10. | <p>Secure the hoses and cables to the <i>gripping clamp, frame</i>.</p> |  <p>xx0700000600</p> <p>Parts:</p> <ul style="list-style-type: none"> • A: Gripping clamp, frame |

© Copyright 2006-2010 ABB. All rights reserved.

Continues on next page

Continued

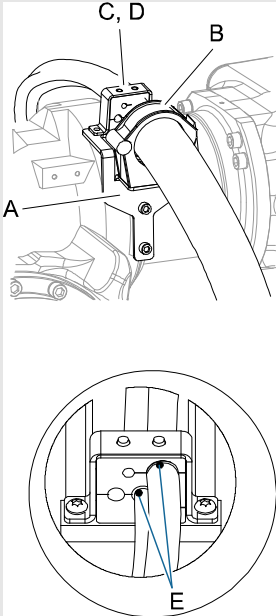
| Action | Note |
|---|---|
| <p>11. Fit the cable package in the <i>gripping clamp, upper arm</i>. Then fit the cables and hoses to the <i>bracket for clamp</i> with the <i>metal clamp with rubber clamp</i>. Lock screws with <i>locking liquid</i>.</p> <p> NOTE! The <i>white markings</i> on the cables shall be visible just outside the <i>rubber clamp</i>.</p> |  <p>x0700000602</p> <p>Parts:</p> <ul style="list-style-type: none"> • A: Bracket for clamp • B: Gripping clamp (on upper arm) • C: Metal clamp with rubber clamp • D: Attachment screws M6x16 quality 8.8-A2F (2 pcs) • E: White markings on cables |

2 Installation

2.2.7. Fitting the lower arm cable package - IRBDP MH 3 LE

Continued

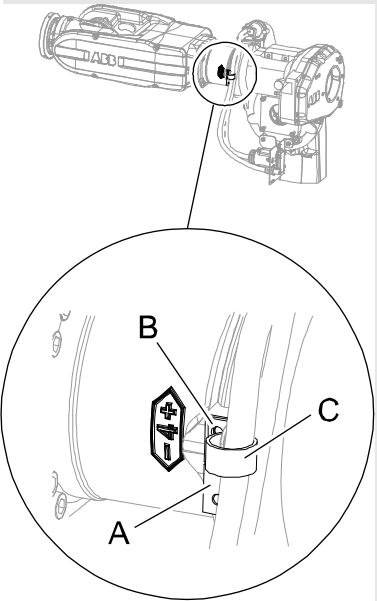
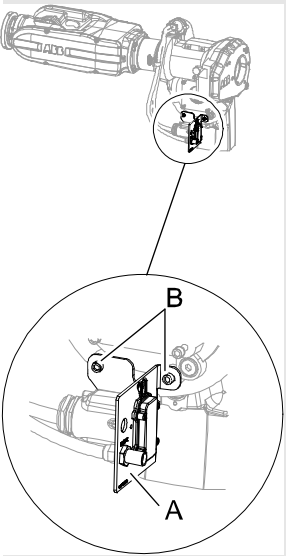
| | Action | Note |
|-----|--|--|
| 12. | Secure the cables and hose to the <i> cable fixing bracket</i> with a <i> velcro strap</i> . |  <p>xx070000585</p> <p>Parts:</p> <ul style="list-style-type: none">• A: Cable fixing bracket• B: Attachment screws M8x16 quality 8.8_A2F (2 pcs)• C: Velcro strap |
| 13. | Connect all cables and hose to the connection plate. |  <p>xx070000588</p> <p>Parts:</p> <ul style="list-style-type: none">• A: Connection plate• B: Attachment screws |

2.2.8. Fitting the upper arm cable package - IRBDP MH 3 UE

Location of upper arm cable package - IRBDP MH 3 UE

The location of the cable package IRBDP MH 3 UE, is shown in the figure below.

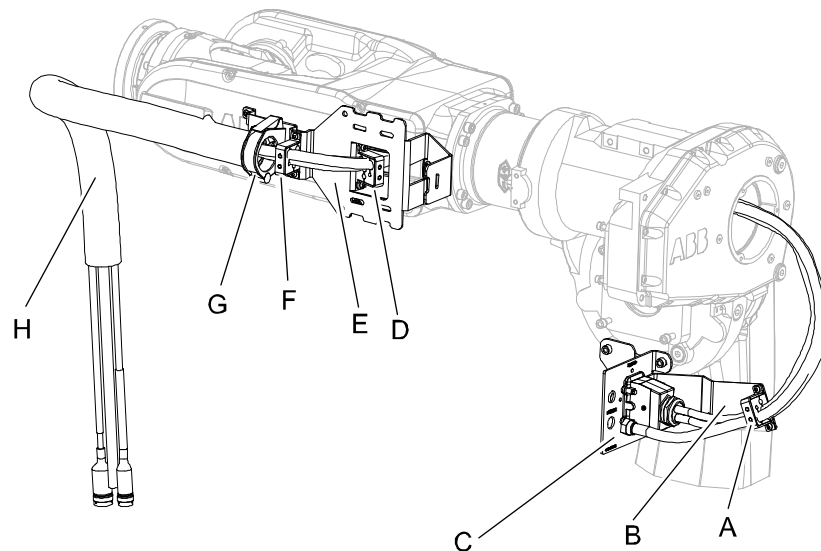

xx0700000580

| | |
|---|--|
| A | Metal clamp with rubber clamp |
| B | Bracket for metal clamp |
| C | Connection plate ax 3 (delivered with cable package IRBDP MH 3 LE) |
| D | Metal clamp with rubber clamp (right) |
| E | Bracket at wrist |
| F | Metal clamp with rubber clamp (left) |
| G | Gripping clamp & clamp half |
| H | Protection hose |

Required equipment

The following equipment is required for fitting the cable package IRBDP MH 3 UE.

| Equipment | Art. no | Note |
|--|-------------|--|
| Locking liquid | 3HAB7116-1 | Loctite 243 For locking screws. |
| Standard toolkit, DressPack/SpotPack | 3HAC17290-7 | The contents are defined in section Toolkits, DressPack/SpotPack on page 257 . |
| Other tools and procedures may be required. See references to these procedures in the step-by-step instructions below. | | These procedures include references to the tools required. |

Continues on next page

2 Installation



2.2.8. Fitting the upper arm cable package - IRBDP MH 3 UE

Continued

Procedure

This procedure details how to fit the cable package IRBDP MH 3 UE.

How to fit the cable package IRBDP MH 3 LE, is detailed in section [Fitting the lower arm cable package - IRBDP MH 3 LE on page 74](#).

| | Action | Note |
|----|---|--|
| 1. |  DANGER! Turn off all electric power, hydraulic and pneumatic pressure supplies to the robot! For Foundry Prime robots: Do not turn off the air pressure to motors and SMB. | |
| 2. |  CAUTION! The cable package is sensitive to mechanical damage. They must be handled with care, especially the connectors, in order to avoid damaging them. | |
| 3. | Push the customer signal and power cables as well as air hose into the upper arm tube from the rear and pull it out of the hole on the side of the wrist where the <i>bracket at wrist</i> is placed. Arrange cables and hose so no cables or hoses are twisted.  NOTE! Be careful not to damage the existing motor cables! | Shown in the figure Location of upper arm cable package - IRBDP MH 3 UE on page 81 . |

Continued

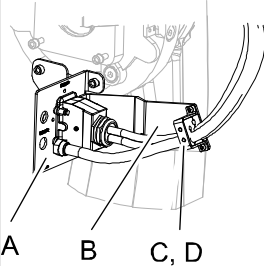
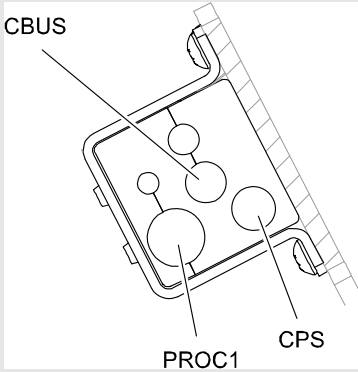
| Action | Note |
|---|---|
| <p>4. Connect cables and hose of the cable package to the <i>connection plate</i>.</p> <p>Also fit the <i>metal clamp with rubber clamp</i> on the <i>bracket for metal clamp</i> with its <i>attachment screws</i>.</p> <p>Lock screws with locking liquid.</p> <p></p> <p>NOTE!</p> <p>Place cables and hose in the correct position! See figure!</p> | <p>Art. no. is specified in section Required equipment on page 81.</p> <p></p> <p>xx0700000605</p> <p>Parts:</p> <ul style="list-style-type: none"> • A: Connection plate • B: Bracket for metal clamp • C: Metal clamp with rubber clamp • D: Attachment screws M6x16 quality 8.8-A2F (2 pcs) <p></p> <p>xx0700000369</p> |

2 Installation

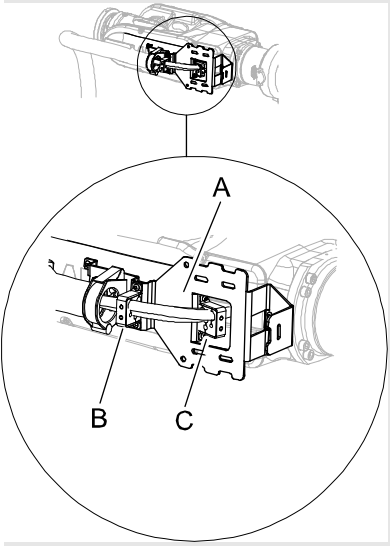
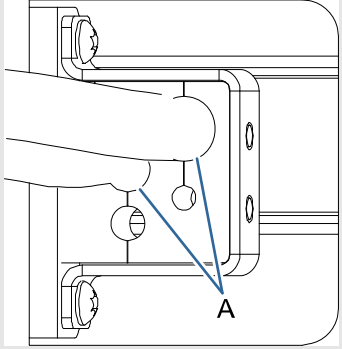

2.2.8. Fitting the upper arm cable package - IRBDP MH 3 UE

Continued

| Action | Note |
|--|--|
| <p>5. Fit the cables and hose to the <i>bracket at wrist</i> with the <i>metal clamp with rubber clamp (right)</i>. Lock screws with <i>locking liquid</i>.</p> <p></p> <p>NOTE! The <i>green color markings</i> on the cables shall be visible just outside of the right metal clamp with rubber clamp.</p> |  <p>xx0700000606</p> <p>Parts:</p> <ul style="list-style-type: none">• A: Bracket at wrist• B: Metal clamp with rubber clamp (left)• C: Metal clamp with rubber clamp (right)  <p>xx0700000607</p> <ul style="list-style-type: none">• A: Green color markings |

© Copyright 2006-2010 ABB. All rights reserved.

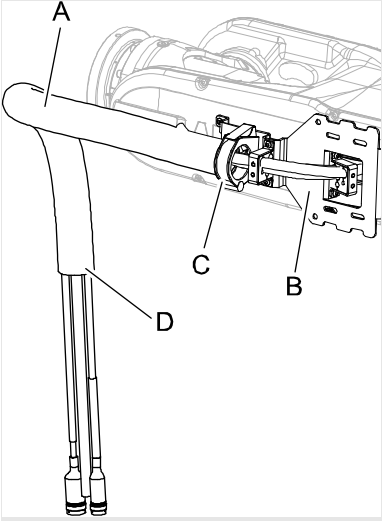
Continued

| Action | Note |
|--|--|
| <p>6. Put the <i>protection hose</i> in the <i>gripping clamp with clamp halves</i>, on the <i>bracket at wrist</i>. If needed, cut the protection hose to desired length.</p> |  <p>xx070000609</p> <p>Parts:</p> <ul style="list-style-type: none"> • A: Protection hose • B: Bracket at wrist • C: Gripping clamp with clamp halves • D: Place for gripping clamp at tool |
| <p>7. Push the cables and hose through the protection hose.</p> | |
| <p>8. Pull the cables and hose back so the desired free length out of the protection hose is achieved.</p> | |
| <p>9. Fit the cables and hose to the <i>bracket at wrist</i> with the <i>metal clamp with rubber clamp (left)</i>. Lock screws with <i>locking liquid</i>.</p> | See figure above! |
| <p>10.  NOTE! When delivered there are no adjustments made to the final location of air hose and cables. Air hose and cables are pulled out completely through the protection hose. The whole package is then wrapped around the arm when delivered. How to adjust the cable package IRBDP MH 3 UE is detailed in section Adjustments of the cable package - IRBDP MH3 UE on page 100.</p> | |
| <p>11. Fit a gripping clamp at the other end of the protection hose. The protection hose is to be fitted on the tool with this gripping clamp with clamp halves.</p> | See position in figure above! |

2 Installation

2.2.9. Fitting the cable package IRBDP SW5 CE (SpotPack Basic)

2.2.9. Fitting the cable package IRBDP SW5 CE (SpotPack Basic)

Location of the cable package

The location of the cable package IRBDP SW5 CE (SpotPack Basic) is shown in the figure below.

How to fit the attachments for the process cable package IRBDP SW5 CE is detailed in section *Fitting the attachments of IRBDP SW5 CE (SpotPack Basic) on page 61*.

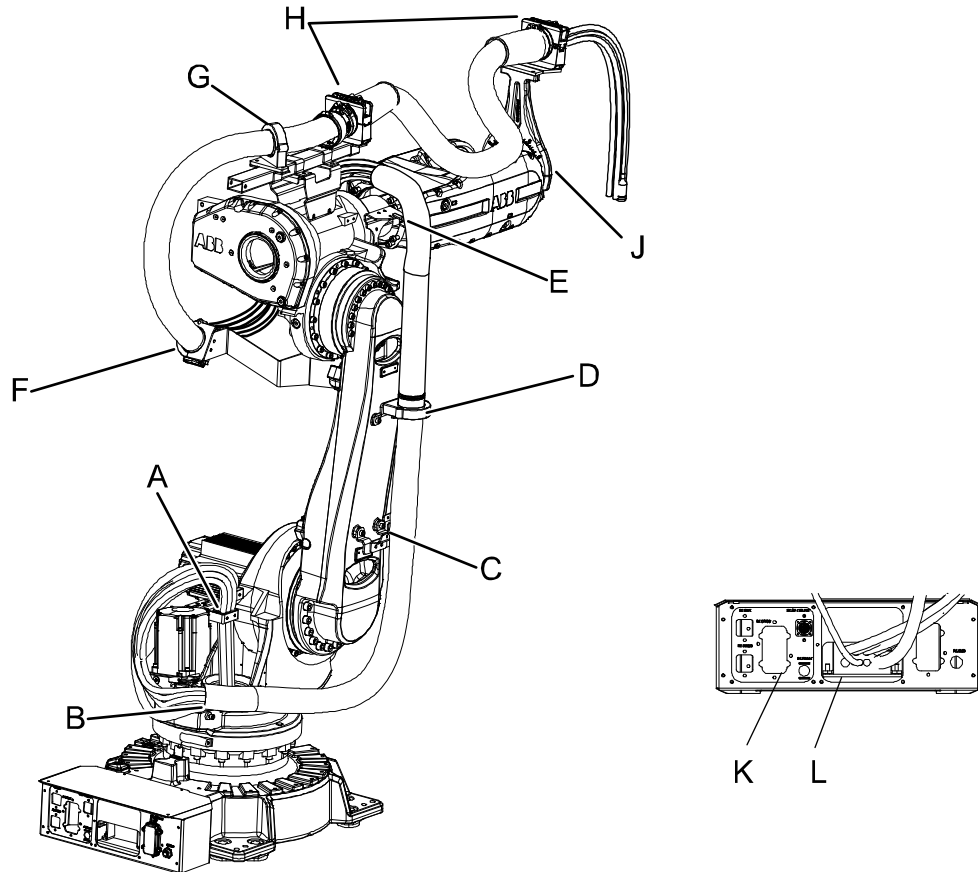

xx080000111

| | |
|---|---|
| A | Cable and hose clamp |
| B | Spiral hose clamp (bracket back lower) |
| C | Spiral hose clamp (lower bracket) |
| D | Gripping clamp (lower bracket) |
| E | Spiral hose clamp (spiral hose bracket) |
| F | Gripping clamp (axis 3 clamp mount) |
| G | Gripping clamp (adjustable bracket) |
| H | Ball joint housing |
| J | Process cable support axis 6 |
| K | Customer plate |
| L | Clamp holder with plastic clamp |

© Copyright 2006-2010 ABB. All rights reserved.

Continues on next page



Continued

Required equipment

| Equipment | Art. no. | Note |
|--|-------------|--|
| Process cable package IRBDP SW5 CE (SpotPack Basic) | - | See spare parts. |
| Standard toolkit, DressPack/SpotPack | 3HAC17290-7 | The contents are defined in section Toolkits, DressPack/SpotPack on page 257 . |
| Other tools and procedures may be required. See references to these procedures in the step-by-step instructions below. | | These procedures include references to the tools required. |

Procedure

Use this procedure to fit the cable package IRBDP SW5 CE (SpotPack basic).

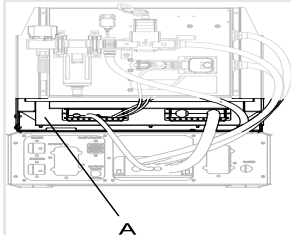
| | Action | Note |
|----|--|---|
| 1. |  <p>DANGER! Turn off all electric power, hydraulic and pneumatic pressure supplies to the robot! For Foundry Prime robots: Do not turn off the air pressure to motors and SMB.</p> | |
| 2. |  <p>CAUTION! The cable package is sensitive to mechanical damage. They must be handled with care, especially the connectors, in order to avoid damaging them.</p> | |
| 3. | <p>Remove the <i>rear top cover plate</i> in the back of the robot base.</p> |  <p>xx080000081</p> <p>Parts:</p> <ul style="list-style-type: none"> A: Rear top cover plate |

2 Installation

2.2.9. Fitting the cable package IRBDP SW5 CE (SpotPack Basic)

Continued

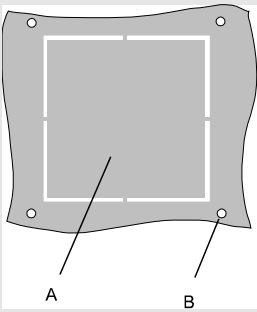
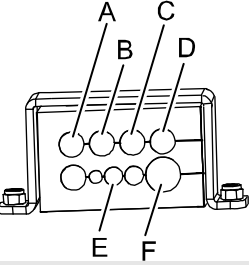
| Action | Note |
|---|--|
| <p>4. Remove the <i>part of the backplate</i> where process and customer plates are supposed to be fitted. Hit the removable part with a plastic mallet or similar without damaging other parts of the backplate.</p> <p></p> <p>NOTE! Only needed when the cable package is fitted for the first time!</p> | <p></p> <p>xx0700000404</p> <p>Parts:</p> <ul style="list-style-type: none"> • A: Removable part of backplate • B: Holes for attachment screws |
| <p>5. Run the cables and hoses down through the center hole of gearbox axis 1 in the following order:</p> <ul style="list-style-type: none"> • Signal cable • Hoses, slightly to the right of the signal cable • Check that signal cable and hoses do not end up between the motor cables • Check that cables and hoses do not cross each other. | |
| <p>6. Fit the process cable package to the frame with the <i>cable and hose clamp</i>.</p> | <p>Shown in the figure Location of the cable package on page 86.</p> |
| <p>7. Fit the process cable package to the <i>clamp holder with plastic clamp</i>. Position of cables and hoses is shown in the figure.</p> | <p>Shown in the figure Location of the cable package on page 86.</p> <p></p> <p>xx0800000079</p> <p>Positions:</p> <ul style="list-style-type: none"> • A: PROC 1 (blue) • B: PROC 2 (green) • C: PROC 3 (red) • D: PROC 4 (black) • E: Signal cable • F: Weld cable |

© Copyright 2006-2010 ABB. All rights reserved.

Continues on next page

Continued

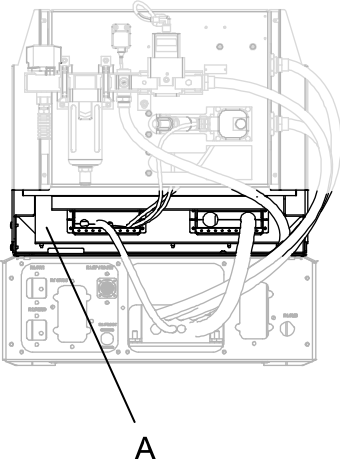
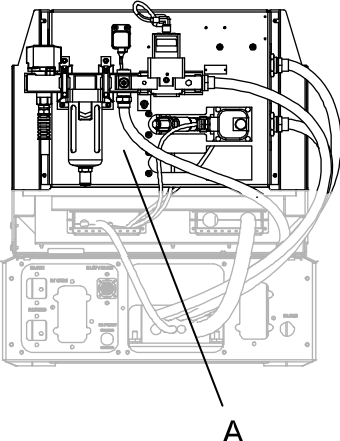
| Action | Note |
|---|---|
| <p>8. Fit the process cable package to the <i>connection box</i>.</p> |  <p>xx0800000082</p> <p>Parts:</p> <ul style="list-style-type: none"> • A: Connection box |
| <p>9. Fit the process cable package to the <i>water and air unit</i>.</p> |  <p>xx0800000083</p> <p>Parts:</p> <ul style="list-style-type: none"> • A: Water and air unit |
| <p>10. Fit the process cable package to the bracket back lower with the <i>spiral hose clamp</i>.</p> | <p>Shown in the figure Location of the cable package on page 86.</p> |
| <p>11. Fit the process cable package to the lower bracket with the <i>spiral hose clamp</i>.</p> | <p>Shown in the figure Location of the cable package on page 86.</p> |
| <p>12. Fit the process cable package to the <i>gripping clamp</i> on the <i>lower bracket</i>.</p> | <p>Shown in the figure Location of the cable package on page 86.</p> |
| <p>13. Secure the process cable package with the <i>velcro straps</i>.</p> | <p>Shown in the figure Location of the cable package on page 86.</p> |
| <p>14. Fit the process cable package to the <i>gripping clamp</i> on the <i>axis 3 clamp mount</i>.</p> | <p>Shown in the figure Location of the cable package on page 86.</p> |
| <p>15. Fit the process cable package to the <i>gripping clamp</i> on the <i>adjustable bracket</i>.</p> | <p>Shown in the figure Location of the cable package on page 86.</p> |
| <p>16. Fit the process cable package in the <i>ball joint housing</i> on the <i>adjustable bracket</i>.</p> | <p>Shown in the figure Location of the cable package on page 86.</p> |

Continues on next page

2 Installation

2.2.9. Fitting the cable package IRBDP SW5 CE (SpotPack Basic)

Continued

| | Action | Note |
|-----|---|--|
| 17. | Fit the process cable package on the <i>ball joint housing</i> on the <i>process cable support axis 6</i> . | Shown in the figure Location of the cable package on page 86 . |

2.2.10. Inspection, DressPack lower arm

General

In order to ensure adequate life of the equipment, it is vital that the cables and hoses are properly installed and operated correctly, with their movement patterns well within the acceptable limits.

This procedure describes how to inspect the DressPack lower arm installation in this regard.

Procedure, general

| | Action | Note |
|----|---|---|
| 1. | Inspect the process cable package | Detailed in section <i>Procedure, process cable package on page 91</i> |
| 2. | Inspect all attachments, brackets and any other hardware securing or guiding the protective hose. | Detailed in section <i>Procedure, attachments and brackets on page 91</i> |

Procedure, process cable package

| | Action | Note |
|----|--|--|
| 1. | <i>Do not bend</i> any cable or hose excessively! Also, make sure no cable or hose is twisted. | Minimum bending radius is approximately 10 x the cable or hose diameter. |
| 2. | Make sure all cables straps are tight enough to prevent the cable package from moving in any undesired way. | |
| 3. | Make sure the cable package is properly connected at the connection plate as well as at the robot base. | |
| 4. | Make sure no hoses or cables, or parts thereof, touch any part of the robot structure in a way that may cause wear. | |
| 5. | Make sure all cables and hoses move smoothly together during operation and that no part of the cable package moves in a different pattern. | |
| 6. | Make sure that cables, hoses or packages do not rub against <i>any sharp corner of anything</i> (not just the robot itself)! | |
| 7. | Make sure all connection points are well tightened and sealed in order to avoid leaks. | |

Procedure, attachments and brackets

| | Action | Note |
|----|--|--|
| 1. | Recheck all cable clamps securing the process cable package and protective hose for tightness. | Tightening torques are specified: <ul style="list-style-type: none"> For <i>standard tightening torques</i> - See tightening torque table in chapter References. For <i>non standard tightening torques</i> see chapter <i>Installation</i>. |

2 Installation

2.2.11. Inspection, DressPack upper arm

2.2.11. Inspection, DressPack upper arm

General

In order to ensure adequate life of the equipment, it is vital that the cables and hoses are properly installed and operated correctly, with their movement patterns well within the acceptable limits.

This procedure below details how to inspect the DressPack upper arm installation in this regard.

Procedure, general

| | Action | Note |
|----|---|--|
| 1. | Inspect all attachments, brackets and any other hardware securing or guiding the protective hose. | Detailed in section <i>Attachments and brackets on page 92</i> . |
| 2. | Inspect the process cable package. | Detailed in section <i>Cables and hoses on page 93</i> . |
| 3. | Make sure all cables and hoses are securely fixed and connected. | Detailed in section <i>Securing and connecting on page 94</i> . |

Attachments and brackets

This section details each inspection to be carried out, not necessarily in any particular order unless stated.



NOTE!

This procedure is not applicable to cable package IRBDP MH3 UE.

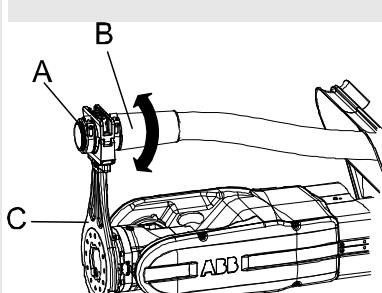
| | Action | Note |
|----|--|--|
| 1. | <p>Make sure the sliding surfaces of the slide sleeve has not been damaged. Check this with normal hand force:</p> <ul style="list-style-type: none"> • grab hold of the package • pull and turn to make sure that the package is free to slide. |  <p>xx0600003176</p> <ul style="list-style-type: none"> • A: Slide sleeve, slide surface • B: Hose reinforcement • C: Process cable support, axis 6 |



NOTE!

A damaged surface may potentially prevent the cable package from rotating causing excessive wear.

Continued

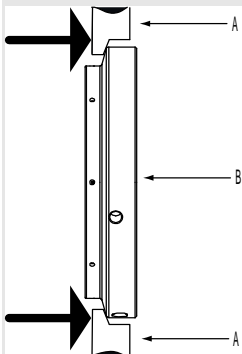
| Action | Note |
|--|--|
| <p>2. Check that the <i>process cable support, axis 6</i> is pushed forward completely against the <i>turning disk, axis 6</i>. See illustration!</p> |  <p>xx0400001040</p> <p>Parts:</p> <ul style="list-style-type: none"> • A: Process cable support, axis 6 • B: Turning disk, axis 6 |
| <p>3. Check the tightening torque.</p> | <p>Correct tightening torque: 70 Nm.</p> |
| <p>4. Check the angle of the <i>process cable support, axis 6</i> in relation to the movement pattern of the cable package. If required, change the position of the process cable support, axis 6 to ensure that the cable package does not get stretched or bent excessively.</p> | |

Cables and hoses

The procedure below details each inspection to be carried out, not necessarily in any particular order if not so stated.

| Action | Note |
|--|---|
| <p>1. <i>Do not bend</i> any cable or hose excessively!</p> | <p>Minimum bending radius is approximately 10 x the cable or hose diameter.</p> |
| <p>2. Make sure no cables or hoses are twisted.</p> | |
| <p>3. Make sure that all hoses and cables to gun or gripper are long enough to avoid stretching during any part of the cycle.</p>  <p>NOTE! (Not applicable to cable package IRBDP MH3 UE) When cutting the cables/hoses, make sure the length is sufficient between slide sleeve to fixation point (strap) on the tool, to enable cable and hoses to rotate in the process cable support, axis 6, as detailed above!</p> | <p>(Not applicable to cable package IRBDP MH3 UE) Do not strap closer than 400 mm from slide sleeve.</p> |

Continues on next page

2 Installation

2.2.11. Inspection, DressPack upper arm

Continued

| | Action | Note |
|----|--|--|
| 4. | Make sure that cables are clamped with straps in a way that there is no movement at connectors. | Use only wide straps or velcro straps in order not to damage the cables and hoses. |
| 5. | Make sure that no hoses or cables, or parts thereof, touch any part of the robot structure in a way that may cause wear. | |
| 6. | Make sure that no hoses or cables, or parts there of, touch any part of the <i>surrounding equipment</i> in a way that may cause wear. | |
| 7. | Make sure all cables and hoses move smoothly together during operation and that no part of the cable package moves in a different pattern. | |
| 8. | Make sure cable loops are not allowed to swing as the robot runs. | |

Securing and connecting

The procedure below details each inspection to be carried out, not necessarily in any particular order unless stated.

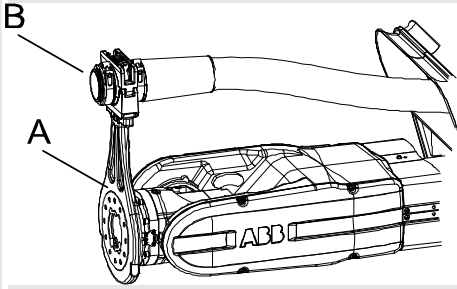
| | Action | Note |
|----|--|---|
| 1. | Recheck all cable clamps securing the process cable package and protective hose for tightness. | Tightening torques are specified: <ul style="list-style-type: none"> For <i>standard tightening torques</i> - See tightening torque table in chapter References. For <i>non standard tightening torques</i> - See Installation chapter. |
| 2. | Make sure all cable straps are tight enough to prevent the cable package from moving in any undesired way. The cable ties should not be too narrow. This may damage the cables/hoses. | |
| 3. | <p>(Not applicable to cable package IRBDP MH3 UE)</p> <p>Do not strap, or in any other way secure, the cables/hoses to the process cable support, axis 6 in a way that may prevent the assembly to swivel properly. Whenever strapping the cables/hoses to the process cable support, axis 6, make sure the assembly is free to swivel properly.</p> <p> NOTE! Do not strap closer than 400 mm from the slide sleeve!</p> |  <p>xx0600003177</p> <ul style="list-style-type: none"> A: Process cable support, axis 6 B: Slide sleeve |
| 4. | When securing cables and hoses with cable ties: <i>never</i> overtighten the ties! This may damage the equipment. | |

Continues on next page

Continued

| | Action | Note |
|----|---|-------------|
| 5. | Make sure that the cable package have been properly connected at the base as well as at the tool on the robot turning disk. | |
| 6. | Make sure all connection points are well tightened and sealed in order to avoid leaks. | |
| 7. | Make sure the weight of the cable package is secured to the tool in order to avoid straining the connectors! | |

2 Installation

2.3.1. Adjustments of - IRBDP MH2 UE and IRBDP SW2 UE

2.3 DressPack adjustments

2.3.1. Adjustments of - IRBDP MH2 UE and IRBDP SW2 UE



NOTE!

This section is **not** applicable to cable package IRBDP MH3 UE! How to adjust cable package IRBDP MH3 UE is detailed in *Adjustments of the cable package - IRBDP MH3 UE on page 100*.

General

The instructions below details how to adjust the routing of the DressPack to avoid reducing its life.

How to adjust the tension arm unit, see section *Adjusting tension arm unit on page 200*.

Hose reinforcement

Should the hose reinforcement get strained under the upper arm during the work cycle, the following tips may assist in alleviating the problem.

The illustration below shows a DressPack upper arm fitted to an IRB 6600, but the problem is identical to all robot types.

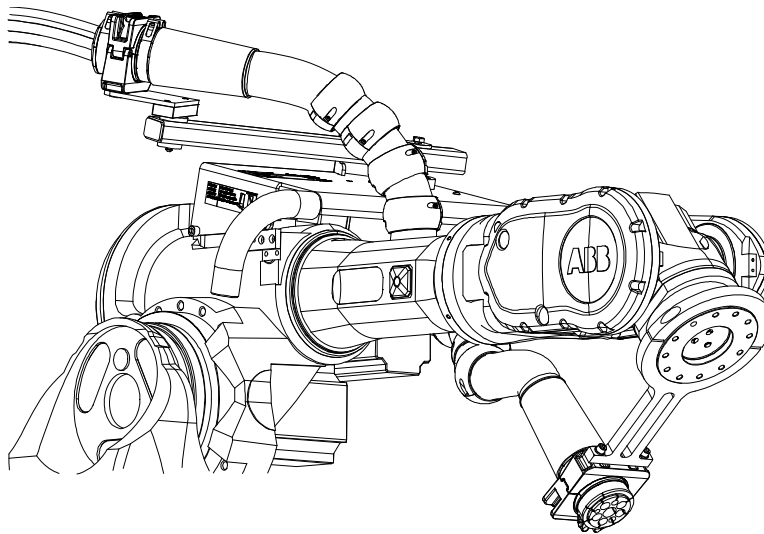

xx0500001560

| | Action | Note |
|----|--|------|
| 1. | Either, try changing the robot position or orientation at the particular position to reduce the angle of axis 5 in combination of axis 6, | |
| 2. | or rotate the attachment angle of the process cable support, axis 6 slightly. | |

© Copyright 2006-2010 ABB. All rights reserved.

Continues on next page

Hoses and cables too long around the wrist

If the DressPack upper arm is too long, the hose loop may get obstructed or caught by the brackets or any other equipment.

The illustration below shows a DressPack upper arm fitted to an IRB 6600, but the problem is identical to all robot types.

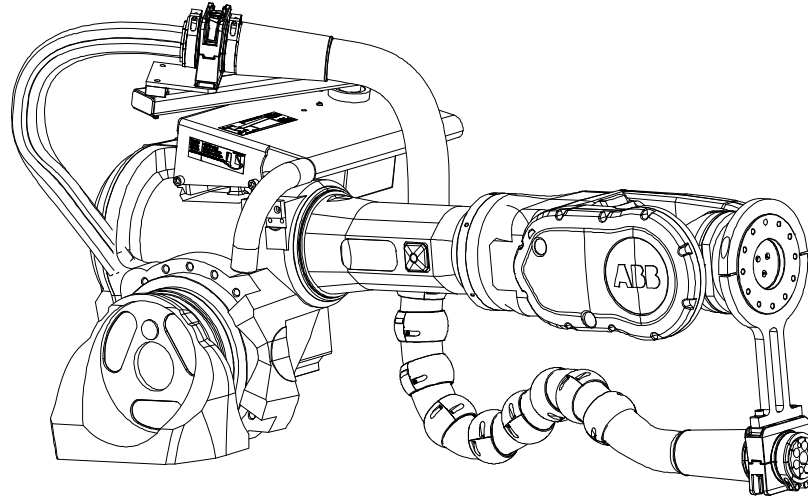

xx0500001561

| | Action | Note |
|----|---|--|
| 1. | Adjust the tension arm unit to reduce the slack in the hose package Adjusting tension arm unit on page 200 . | |
| 2. | If this does not solve the problem, the robot movements must be limited. If this is not done, there is a substantial risk of damaging the hose/cable package. | |
| 3. | After changing the DressPack installation, it needs to be inspected to ensure the function. | Detailed in section Preventive inspection, DressPack upper end on page 148 . |

2 Installation

2.3.1. Adjustments of - IRBDP MH2 UE and IRBDP SW2 UE



Continued

Hoses and cables too long

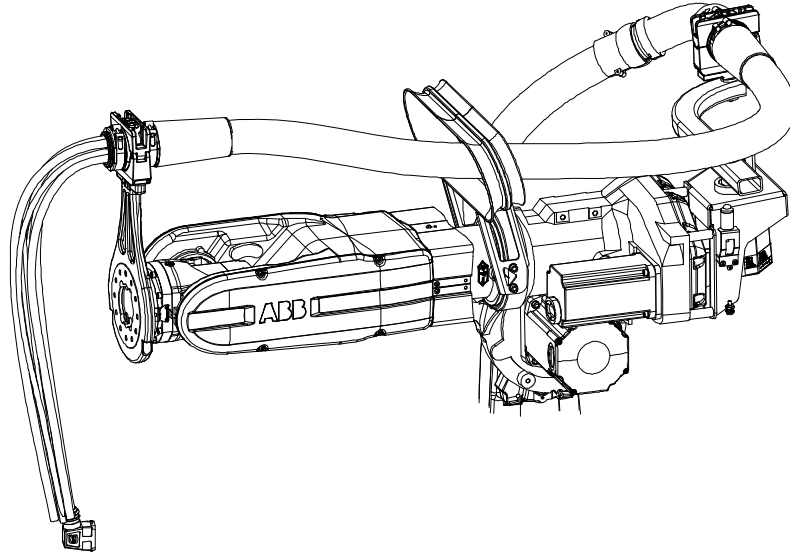
The hoses and cables at the end of the hose package are too long. The length should allow any required robot movement without stretching and also allow rotation inside the process cable support, axis 6.



xx0600003164

| | Action | Note |
|----|---|---|
| 1. | <p>Cut the weld cable and hoses to a length that will suit the application before making any connections to the tool.</p>  <p>NOTE!</p> <p>Do not pull back the cables and hoses through the protective hose!</p> <p>Note the length of cables and hoses to make it easier for a later change to a spare cable package.</p> | <p>Do not cut the hoses and weld cable too short. During programming it can be necessary to adjust the position of the process cable support, axis 6.</p> |
| 2. | <p>Loop the excess hoses and cables in a way that enables securing them with <i>cable clamps</i> or similar allowing quick replacement of the package.</p> | <p>When securing cables and hoses with cable ties: <i>never</i> overtighten the ties! This may damage the equipment.</p>  <p>NOTE!</p> <p>Use wide cable ties!</p> |
| 3. | <p>After changing the DressPack installation, it needs to be inspected to ensure the function.</p> | <p>Detailed in section <i>Preventive inspection, DressPack upper end on page 148.</i></p> |

© Copyright 2006-2010 ABB. All rights reserved.

Continues on next page

Process cable package too short

If the DressPack upper arm is too short, unacceptable strain may be put on the cables, hoses and connectors.

| | Action | Note |
|----|--|---|
| 1. | Make sure the correct cable package is used. | Check the Spare Parts section for article numbers! |
| 2. | Make sure all attachments and supports are <i>fitted correctly</i> . | Detailed in section Fitting the cable package IRBDP SW2 CE IRBDP MH2 CE and on page 67. If required adjust their fitting positions! When securing cables and hoses with cable ties: <i>never</i> overtighten the ties! This may damage the equipment. |
| 3. |  NOTE! If the DressPack cable package appears to be fitted too strained, the reason can be that the tension arm is adjusted too tightly. | How to adjust the tension arm is detailed in section Adjusting tension arm unit on page 200. |
| 4. | After changing the upper part of the DressPack installation, it needs to be inspected to ensure the function. | Detailed in section Preventive inspection, DressPack upper end on page 148. |

2 Installation

2.3.2. Adjustments of the cable package - IRBDP MH3 UE

2.3.2. Adjustments of the cable package - IRBDP MH3 UE

Overview



The procedure below details how to adjust the routing of the upper arm cable package - IRBDP MH3 UE, in order to avoid reducing its life.

Hoses and cables too long around the wrist

Depending on robot version and gripper design, the length of the protection hose, air hose and/or cables has to be adjusted. Protection hose and air hose can be cut to the desired length.

It is possible to fit the protection hose in different positions, depending on where the gripping clamp is fitted on the bracket. There are more than one position to fit the gripping clamp.

The procedure below details how to fit gripping clamp and protection hose in the different positions.

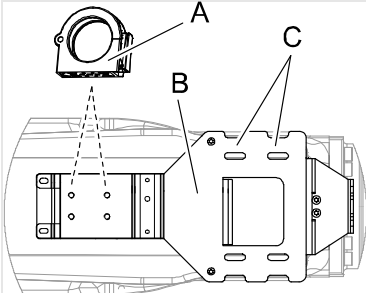
| | Action | Note |
|----|--|--|
| 1. |  <p>DANGER! Turn off all electric power, hydraulic and pneumatic pressure supplies to the robot! For Foundry Prime robots: Do not turn off the air pressure to motors and SMB.</p> | |
| 2. |  <p>CAUTION! The cable package is sensitive to mechanical damage. They must be handled with care, especially the connectors, in order to avoid damaging them.</p> | |
| 3. | Fit the <i>gripping clamp</i> in the best suitable position on the <i>bracket</i> . Choose one of the positions shown in the figure. |  <p>xx0700000611</p> <p>Parts:</p> <ul style="list-style-type: none"> • A: Gripping clamp • B: Bracket at wrist • C: Position for straps |
| 4. | If the cables are too long it is possible to pull them back out of the protection hose and then put them in a loop. Fit the cables with the enclosed <i>straps</i> on the bracket. | Shown in the figure above. |

© Copyright 2006-2010 ABB. All rights reserved.

2.3.3. Adjustment of the cable package - IRBDP SW5 CE (SpotPack basic)





Overview

The position of the ball joint housing and gripping clamp on the adjustable bracket is different depending on robot version.

Adjustment procedure

The procedure below details how to adjust the position of the process cable package SpotPack basic before commissioning.

It is possible to place the ball joint housing and gripping clamp in different positions on the adjustable bracket in order to get the smoothest movements possible of the process cable package and preventing premature wear.

| | Action | Note |
|----|--|---|
| 1. |  <p>DANGER! Turn off all electric power, hydraulic and pneumatic pressure supplies to the robot! For Foundry Prime robots: Do not turn off the air pressure to motors and SMB.</p> | |
| 2. |  <p>CAUTION! The cable package is sensitive to mechanical damage. They must be handled with care, especially the connectors, in order to avoid damaging them.</p> | |
| 3. | Fit the <i>ball joint housing</i> and <i>gripping clamp</i> on the adjustable bracket with the brackets and attachment screws. | <p>Detailed in section Fitting the attachments of IRBDP SW5 CE (SpotPack Basic) on page 61.</p>  <p>NOTE! Place the axis 6 bracket in a way that axis 5 doesn't press the DressPack against the robot arm in any position or movement in the working programs of the robot.</p>  <p>NOTE! Do not secure the attachment screws completely at this point! It must still be possible to move the ball joint housing and gripping clamp back and forth on the adjustable bracket.</p> |

Continues on next page

2 Installation

2.3.3. Adjustment of the cable package - IRBDP SW5 CE (SpotPack basic)

Continued

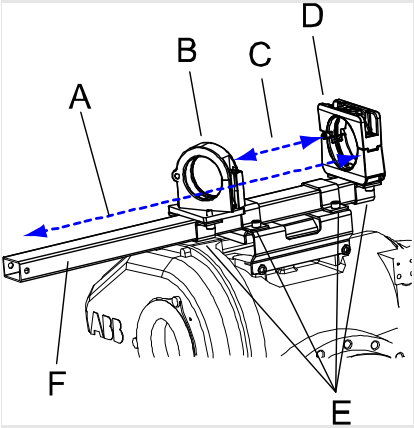
| | Action | Note |
|----|--|--|
| 4. | Fit the process cable package in the ball joint housing and gripping clamp. | Detailed in section Fitting the cable package IRBDP SW5 CE (SpotPack Basic) on page 86. |
| 5. | <p>Adjust the process cable package in a way that it will move smoothly in accordance to the movements of the robot's axes 4, 5 and 6, by putting the <i>ball joint housing</i> and <i>gripping clamp</i> in the best position possible. The adjustable bracket is also possible to put in different positions depending on robot model and variant.</p> <p>Adjust the position of the <i>adjustable bracket</i> in order to adapt the position of the process cable package to the different arm lengths and movements of the wrist and upper arm. The adjustable bracket shall be fitted as far back as possible in order to allow the DressPack to follow the movements of the robot arm. The process cable package must not be wound hard against the robot arm at any given position while the robot is moving.</p> <div data-bbox="480 981 555 1055" style="text-align: center;">  </div> <p>NOTE!</p> <p>If the process cable package is fitted wrongly it will result in too much rubbing against the robot. This will result in increased wear of the cable package.</p> | <div data-bbox="951 454 1366 880" style="text-align: center;">  </div> <p>xx0800000109</p> <p>Parts:</p> <ul style="list-style-type: none"> • A: Position can be adjusted depending on which cable package is used. • B: Gripping clamp • C: Distance and position can be adjusted depending on robot model and version, and cable package. • D: Ball joint housing • E: Bracket • F: Adjustable bracket |
| 6. | When fitting the <i>gripping clamp</i> on the adjustable bracket, fit it 420 mm behind the <i>ball joint housing</i> . | Pos C in the figure above. |
| 7. | Secure the attachment screws of the brackets holding the ball joint housing and gripping clamp. Lock screws with locking liquid. | |
| 8. | If there is any exceptional strain on the process cable package, adjust the position of the ball joint housing and gripping clamp further. | |
| 9. | Depending on the actual fitting of the DressPack and the robot program, the protective sleeves may have to be moved in order to prevent the protection hose from being worn directly while rubbing against robot and/or wrist. | |

© Copyright 2006-2010 ABB. All rights reserved.

2.3.4. Inspection during programming and test-running

General

In order to ensure adequate life of the equipment, it is vital that the cables and hoses are properly installed and operated correctly, with their movement patterns well within the acceptable limits.

Checking the cable package at the upper end

This procedure details how to inspect the DressPack upper end installation during programming and test-running the complete installation the very first times.

IRBDP MH2 UE, IRBDP SW2 UE, IRBDP SW2 CE and IRBDP SW5 CE

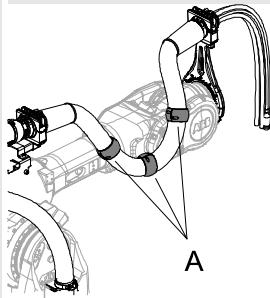
| Action | Note |
|---|---|
| Inspect the DressPack upper arm installation. | Detailed in section Inspection, DressPack upper arm on page 92 . |
| Check the position of the process cable support axis 6, in relation to the final movement pattern of the robot wrist. | Make a note of where the process cable support axis 6 was finally positioned to make it easier to replace it in the future. |
| If required, protective sleeves may be fitted. Place these where they prevent the protective hose from rubbing against the robot's upper arm as much as possible. |  <p>xx0800000084 IRBDP SW5 CE Parts:</p> <ul style="list-style-type: none"> A: Protective sleeves <p>Make a note of where the protective sleeves were finally positioned to make it easier to replace them in the future.</p> |
| Check the operating cycle of the robot, to make sure the movement pattern of the wrist does not cause extensive wear or strain of the cable package. | If required, re-program the robot movement pattern! |
| Large rotating movements of the upper arm (axes 4 and 6 combined) may cause twisting of the DressPack. | When programming such movements, we recommend that the rotating movement of axis 6 is ordered before that of axis 4. This reduces the risk of damaging the DressPack upper arm. |
| Make sure the upper arm protective hose does not get flattened during rotating upper arm movements. | Flattening indicates an overstressed hose and increases the risk of damaging the DressPack upper arm. |

2 Installation

2.3.4. Inspection during programming and test-running

Continued

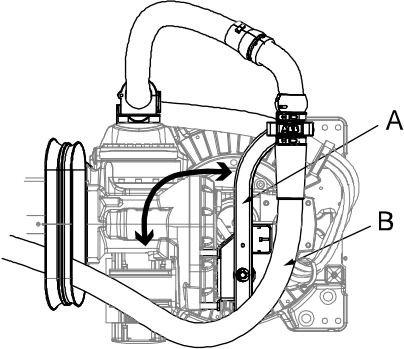
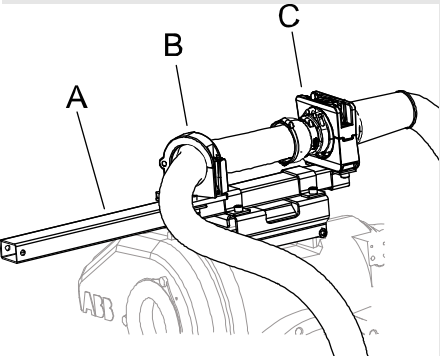
| Action | Note |
|--|--|
| <p>Make sure no combined rotating movements of axes 5 and 6 causes collisions between the <i>cables/hoses</i> or the <i>process cable support axis 6</i> and the upper arm.</p> <p>Such movements may also cause excessive bending of cables or hoses.</p> | <p>Collisions and excessive bending will <i>increase</i> the risk of damaging the equipment.</p> <p>Minimum bending radius: 10 x cable/hose diameter.</p> |
| <p>Valid for IRBDP MH2 UE, IRBDP SW2 UE & IRBDP SW2 CE.</p> <p>Make sure that the movements of the <i>tension arm</i> are smooth and do not jerk the cable package.</p> |  <p>xx0600003189</p> <p>Parts:</p> <ul style="list-style-type: none"> • A: Tension arm (seen from above) • B: Process cable package <p>If required, increase or reduce the amount of spring tension of the tension arm unit.</p> |
| <p>Valid for IRBDP SW5 CE</p> <p>Make sure all movements at the <i>adjustable bracket with ball joint housings</i> and <i>gripping clamp</i> are smooth and do not jerk the process cable package.</p> |  <p>xx0800000085</p> <p>Parts:</p> <ul style="list-style-type: none"> • A: Adjustable bracket • B: Gripping clamp • C: Ball joint housing |
| <p>If any of the actions recommended above, cause you to change the DressPack installation, it must be reinspected.</p> | <p>Detailed in section Inspection, DressPack upper arm on page 92.</p> |
| <p>Make sure that no parts of the DressPack are in contact with the surroundings.</p> | |

© Copyright 2006-2010 ABB. All rights reserved.

Continues on next page

Continued

IRBDP MH 3 LE and IRBDP MH 3 UE

| | Action | Note |
|--|---|--|
| | Inspect the DressPack upper arm installation before programming and test-running. | Detailed in section Inspection, DressPack upper arm on page 92 . |
| | Check the operating cycle of the robot, to make sure the movement pattern of the wrist does not cause extensive wear or strain of the cable package. | If required, re-program the robot movement pattern! |
| | Make sure the upper arm protective hose <i>does not get flattened</i> during rotating upper arm movements. | Flattening indicates an overstressed hose and <i>increases</i> the risk of damaging the DressPack upper arm. |
| | If any of the actions recommended above, causes a change of the DressPack installation, it must be reinspected. | Detailed in section Inspection, DressPack upper arm on page 92 . |
| | Make sure that no parts of the DressPack are in contact with the surroundings. | |
| | (Only applicable if process cable support axis 6 is used!) Make sure no combined rotating movements of axes 5 and 6 causes collisions between the cables/hoses or the process cable support axis 6, and the upper arm. Such movements may also cause excessive cable/hose bending. | Collisions and excessive bending will increase the risk of damaging the equipment. Minimum bending radius: 10x cable/hose diameter. |

Checking the DressPack at the lower end

This instruction details how to inspect the DressPack lower end installation during programming and test-running the complete installation the very first times.

| | Action | Note |
|----|---|--|
| 1. | Inspect the DressPack at the lower arm installation before programming and test-running. | Detailed in section Inspection, DressPack lower arm on page 91 |
| 2. | Check the operating cycle of the robot, to make sure the movement pattern of the robot does not cause extensive wear or straining on the cable package. | If required, re-program the robot movement pattern! |
| 3. | If any of the actions recommended above, causes changes of the DressPack installation, it must be reinspected. | Detailed in section Inspection, DressPack lower arm on page 91 |

2 Installation

2.4.1. DressPack - Armload parameters and LoadId

2.4 DressPack Armload parameters

2.4.1. DressPack - Armload parameters and LoadId

General

A DressPack is adding load to the robot. If the arm and tool loads are not stated correctly, this will affect the behavior and the wear of the robot.



NOTE!

The extra weight of the DressPack products will affect the armload data and the performance of the robot! The effect differs depending on which type of DressPack product.



NOTE!

The "Add to tool data" shall only be used when stating the effect of the DressPack on tool load manually.

Coordinate system definitions

Coordinate system definitions when defining arm loads.

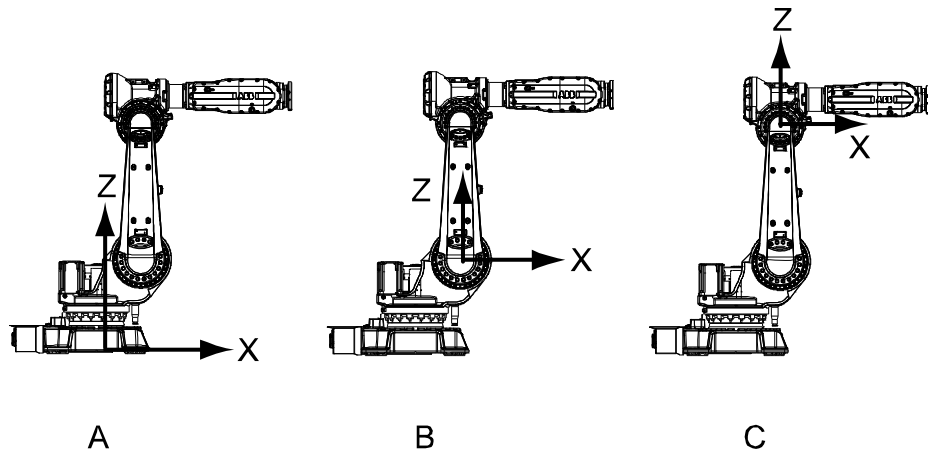

xx0600003186

| | |
|---|--|
| A | Frame - axis 1 |
| B | Lower arm - axis 2 (Z is in the lower arm direction) |
| C | Upper arm - axis 3 (X is in the upper arm direction) |

DressPack for Spotwelding

The following table details values for DressPack - Spotwelding.

| Frame axis 1 | Mass [kg] | Mass CenterX [m] | Mass CenterY [m] | Mass CenterZ [m] |
|--------------|-----------|------------------|------------------|------------------|
| IRB 6620 | 8.5 | -0.177 | 0.000 | 0.265 |

| Lower arm - axis 2 | Mass [kg] | Mass CenterX [m] | Mass CenterY [m] | Mass CenterZ [m] |
|--------------------|-----------|------------------|------------------|------------------|
| IRB 6620 | 4.7 | -0.028 | -0.178 | 0.255 |

© Copyright 2006-2010 ABB. All rights reserved.

Continues on next page

Continued

| Upper arm - axis 3 | Mass [kg] | Mass CenterX [m] | Mass CenterY [m] | Mass CenterZ [m] |
|--------------------|-----------|------------------|------------------|------------------|
| IRB 6620 | 36.4 | -0.183 | 0.017 | 0.314 |

If Tool load is entered manually the following mass shall be added to tooldata **tload**.

| Add to tool data | Mass [kg] | Mass CenterX [m] | Mass CenterY [m] | Mass CenterZ [m] |
|------------------|-----------|------------------|------------------|------------------|
| IRB 6620 | 6.4 | -0.216 | 0.000 | 0.000 |



NOTE!

These values reflect the standard mounting of the Process bracket, pointing straight upwards in the robot calibration position. If the mounting is changed, the X, Y and Z values must be changed correspondingly.

DressPack for Material handling

The following table details values for DressPack - Material handling.

| Frame axis 1 | Mass [kg] | Mass CenterX [m] | Mass CenterY [m] | Mass CenterZ [m] |
|--------------|-----------|------------------|------------------|------------------|
| IRB 6620 | 3.6 | -0.145 | 0.000 | 0.218 |

| Lower arm - axis 2 | Mass [kg] | Mass CenterX [m] | Mass CenterY [m] | Mass CenterZ [m] |
|--------------------|-----------|------------------|------------------|------------------|
| IRB 6620 | 2.1 | -0.023 | 0.020 | 0.030 |

| Upper arm - axis 3 | Mass [kg] | Mass CenterX [m] | Mass CenterY [m] | Mass CenterZ [m] |
|--------------------|-----------|------------------|------------------|------------------|
| IRB 6620 | 30.6 | 0.000 | 0.000 | 0.000 |

If Tool load is entered manually the following mass shall be added to tooldata **tload**.

| Add to tool data | Mass [kg] | Mass CenterX [m] | Mass CenterY [m] | Mass CenterZ [m] |
|------------------|-----------|------------------|------------------|------------------|
| IRB 6620 | 4.9 | -0.191 | 0.000 | 0.000 |



NOTE!

These values reflect the standard mounting of the Process bracket, pointing straight upwards in the robot calibration position. If the mounting is changed, the X, Y and Z values must be changed correspondingly.

2 Installation

2.4.1. DressPack - Armload parameters and LoadId

Continued

Procedures Step 1 - Arm load data

How to define the *Arm load* data is described in *Operating manual - IRC5 with FlexPendant* section *Configuring system parameters*.

All system parameters are described in *Technical reference manual - System parameters*.

Define the arm loads, typically:

- load:_1
- load:_2
- load:_3

The used armload is defined for each arm, irb_1, irb_2, and irb_3.

Procedures Step 2 - Load Identification

It is recommended to use the service routine *Load Identification* (LoadID) to define the load data for an individual robot, as this method not only measures the mass but also the inertia of the tool.

Detailed in *Operating manual - IRC5 with FlexPendant*.

| | Action | Note |
|----|--|--|
| 1. | Check if the cable package prevents movements. | If the cable package prevent the motions. |
| 2. | If not: Run <i>Load Identification</i> . | The DressPack forces on the wrist will "increase" the load parameters, but this is anyhow a good approximation of the actual load case to be considered by the motion planning functions of the robot. |
| 3. | If the cable package prevent the motions: Remove the cable package. | |
| 4. | Make the Load Identification. | |
| 5. | Refit the cable package. | |
| 6. | Add the DressPack load manually. | See Procedures Step 1 - Arm load data on page 108 . |

2.5 DressPack floor

2.5.1. Installation of DressPack floor

Location of DressPack floor

The DressPack floor is made up of several components . Some of these components are specific to this application, while others are used in other applications.

The configuration differs between different DressPack types: H, Se, and HSe. The differences are specified below:

Type H

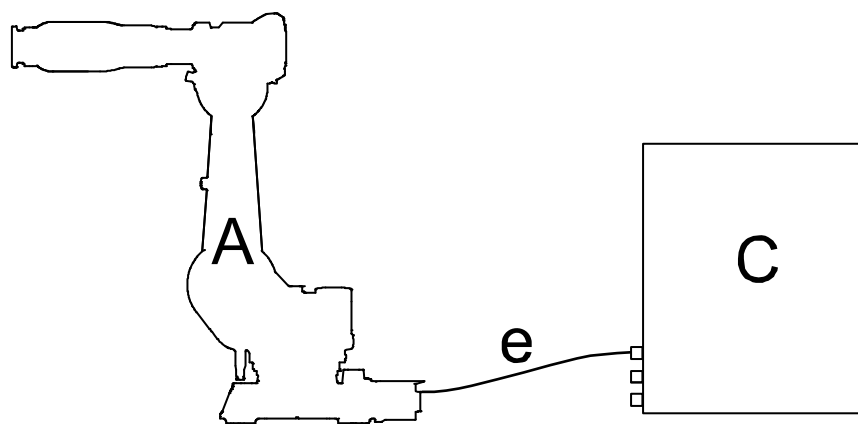

xx0600003152

| | |
|---|---|
| A | Robot |
| C | Controller cabinet |
| e | Harness CP/CS (specified in the <i>Spare parts</i> section) |

Type Se

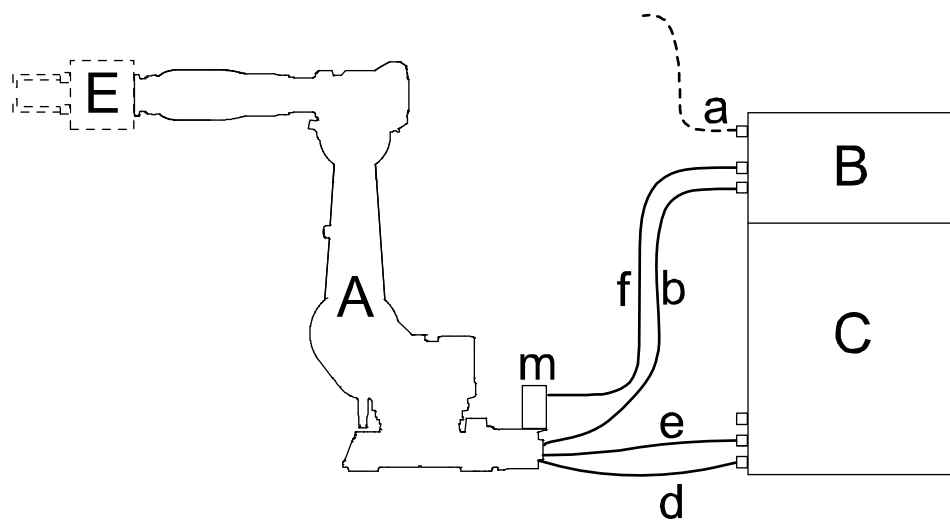

xx0600003154

| | |
|---|---------------------|
| A | Robot |
| B | Spotwelding cabinet |

Continues on next page

2 Installation

2.5.1. Installation of DressPack floor

Continued

| | |
|---|---|
| C | Controller cabinet |
| E | Welding gun (supplied by user) |
| a | Shop weld power supply (supplied by user) |
| b | Floor weld cable |
| d | Power cable |
| e | Harness CP/CS (specified in the <i>Spare parts</i> section) |
| f | Split box cable (for water and air unit) |
| m | Water and air unit |

Type HSe

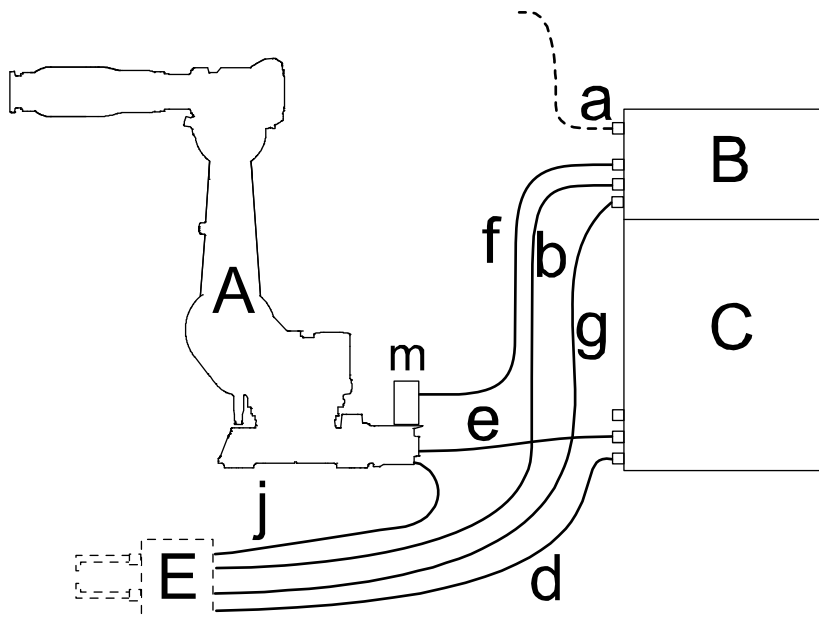

xx0600003153

| | |
|---|---|
| A | Robot |
| B | Spotwelding cabinet |
| C | Controller cabinet |
| E | Stationary/pedestal welding gun (supplied by user) |
| a | Shop weld power supply (supplied by user) |
| b | Floor weld cable |
| d | Power cable |
| e | Harness CP/CS (specified in the <i>Spare parts</i> section) |
| f | Split box cable (for water and air unit) |
| g | Process cable to stationary/pedestal gun |
| j | Resolver cable |
| m | Water and air unit |

© Copyright 2006-2010 ABB. All rights reserved.

Continues on next page



Continued

Required equipment

| Equipment, etc. | Art. no. | Note |
|--------------------------------------|----------------------------------|--|
| DressPack floor | - | A number of versions are available. Detailed in the <i>Spare parts</i> section. |
| Standard Toolkit, DressPack/SpotPack | 3HAC17290-7 | The contents are defined in section Toolkits, DressPack/SpotPack on page 257 . |
| Circuit Diagram | 3HAC026136-001 3HAC026208-001 | |

Installation

The procedure below details how to install the DressPack floor. It does not deal with details specific to each version, such as article numbers, connector types, etc. Such details are specified in the *Spare parts* section.

| | Action | Note |
|----|---|---|
| 1. |  DANGER! Turn off all electric power, hydraulic and pneumatic pressure supplies to the robot! For Foundry Prime robots: Do not turn off the air pressure to motors and SMB. | |
| 2. |  CAUTION! The cable package is sensitive to mechanical damage. They must be handled with care, especially the connectors, in order to avoid damaging them. | |
| 3. | Determine which type of installation is to be done. Study the illustration to decide which cables to connect. | The different types are shown in section Location of DressPack floor on page 109 . |
| 4. | Whenever possible, run all cables/hoses in cable ducts or trenches. Make sure these meet the required standards. | Make sure: <ul style="list-style-type: none"> no floor weld cable is routed along signal cabling to minimize the risk of interference. the duct/trench floor is free from sand and other contamination. This is to reduce the risk of damaging the cable insulation. no cables or hoses rub against any sharp corners which might damage them. |
| 5. | <i>Do not bend or twist any cable or hose excessively!</i> | Minimum bending radius is approximately 10 x the cable or hose diameter. |

Continues on next page

2 Installation

2.5.1. Installation of DressPack floor

Continued

| | Action | Note |
|-----|---|---|
| 6. | Make sure all <i>cable straps</i> are tight enough to prevent the cable package from moving in any undesired way. | |
| 7. | Remember that switching the weld power as well as the water ON and OFF may cause the cables/hoses to move slightly! They may require additional clamping to avoid damage caused by these movements. | |
| 8. | Connect the shop power supply to the spotwelding cabinet. | The supply needs to be configured in such a way that the requirements of the spotwelding cabinet are met: <ul style="list-style-type: none">• Voltage: 400-600 VAC, 50-60 Hz• Fuse: 110 A• Earth fault protection: specified in section <i>Installation of Spotwelding Cabinet on page 131</i>.• Contactor: specified in section <i>Installation of Spotwelding Cabinet on page 131</i>. |
| 9. | Connect the floor weld cable to the <i>robot</i> and spotwelding cabinet connectors. | Specified in section <i>Connections on page 113</i> and the <i>Spare Parts</i> chapter. |
| 10. | Select which <i>CP/CS cabling</i> (customer power/customer signals) to be used. | Some versions include industrial buses. Specified in section <i>Connections on page 113</i> and the <i>Spare Parts</i> chapter. |
| 11. | Connect the CP/CS cable to the <i>robot</i> and <i>controller cabinet connectors</i> . | Specified in section <i>Connections on page 113</i> and the <i>Spare Parts</i> chapter. |
| 12. | If used, connect the <i>split box cable</i> to the water and air unit on the robot and to the spotwelding cabinet <i>connectors</i> . | Specified in section <i>Connections on page 113</i> and the <i>Spare Parts</i> chapter. |
| 13. | If used, connect the process cable to the <i>stationary/pedestal gun</i> and to the spotwelding cabinet and stationary/pedestal gun connectors. | A stationary/pedestal gun is optional. Specified in section <i>Connections on page 113</i> and the <i>Spare Parts</i> chapter. |
| 14. | If used, connect the power cable to the <i>controller cabinet connectors</i> and to the robot or the stationary/pedestal gun (depending on if it is variant <i>Se</i> or <i>HSe</i>). | Specified in section <i>Connections on page 113</i> and the <i>Spare Parts</i> chapter. |
| 15. | If used, connect the resolver cable to the robot base and to the stationary/pedestal gun. | Specified in section <i>Connections on page 113</i> and the <i>Spare Parts</i> chapter. |

© Copyright 2006-2010 ABB. All rights reserved.

Continues on next page

Continued

Connections

The table specifies the connection points of all cables. It does not deal with details specific to each version, such as article numbers, cable lengths, connector types, etc. Such details are specified in the *Spare parts* section. The column Item refers to the graphic above.

Some of the cables occupy the same connectors, so they may not be used simultaneously.

| Item | Connection point A | Cable | Connection point B |
|------|--|---|--|
| a | Shop power outlet | Shop weld power supply | Spotwelding cabinet: protective earth (PE), U, V and W according to circuit diagram. |
| b | Robot: R1.WELD | Floor weld cable | Spotwelding cabinet: as specified in the Circuit Diagram |
| d | Robot: R1.SP | Power cable, axis 7 | Controller cabinet: XS7 |
| e | Robot: R1.CP/CS Robot: R1.CP/CS Robot: R1.CP/CS Robot: R1.CP/CS | Harness CP/CS PROFIB Harness CP/CS CAN Harness CP/CS IBS Harness CP/CS | Controller cabinet: XS13 Controller cabinet: XS13 Controller cabinet: XS13 Controller cabinet: XS13 |
| f | Robot: Water and Air unit: XP101 | Power unit to split box cable | Spotwelding cabinet: XS103 |
| g | Stationary/pedestal gun: SG.CP/CS (optional) | Process cable to stationary/pedestal gun | Spotwelding cabinet: XS104 |
| h | Stationary/pedestal gun: SG.CP/CS | Motor cable | XS77/78 |
| j | Robot: R3.FB7 | Resolver cable, 7 m | Stationary/pedestal gun: FB.M7 |

2 Installation

2.5.2. Inspection, DressPack floor

2.5.2. Inspection, DressPack floor

General

In order to ensure adequate life of the equipment, it is vital that the cables and hoses are properly installed and operated correctly, with their movement patterns well within the acceptable limits.

This instruction details how to inspect the DressPack floor installation in this regard.

Procedure, process cable package

This section details each inspection to be carried out, not necessarily in any particular order unless stated.

| | Action | Note |
|----|--|------|
| 1. | Make sure that the cable package is properly connected at the robot base as well as at the other end. | |
| 2. | Make sure that no hoses or cables, or parts thereof, are routed in such a way that they are subjected to wear, for example hoses being run over by fork lifts etc. | |
| 3. | Make sure that no cables or hoses rub against any sharp corners which might damage them. | |
| 4. | Make sure all connection points are well tightened and sealed in order to avoid leaks. | |

2.6 Water & air unit

2.6.1. Installation of Water and air unit

Overview

This section details how to install Water and air unit type S and type Sb (SpotPack Basic).

Location of Water and air unit, type S

The Water and air unit type S is located as shown in the figure below.

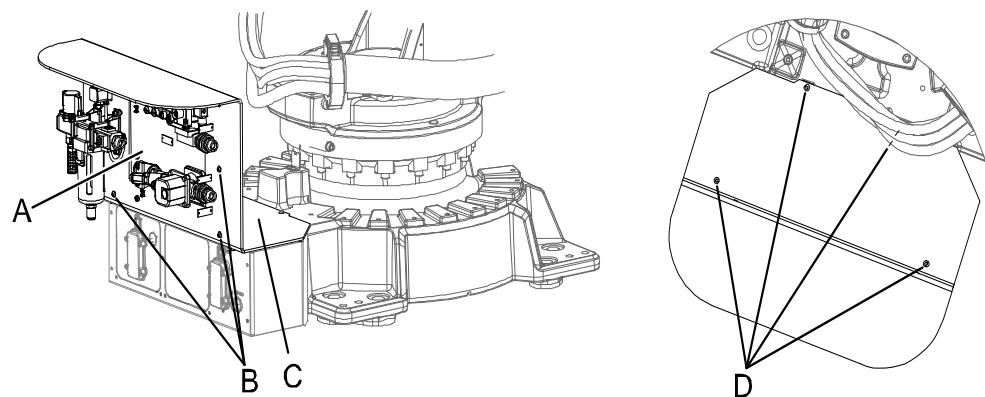

xx0600003205

| | |
|---|--|
| A | Water and air unit, type S |
| B | Attachment screws M6x8 quality 8.8-A2F, Water in and water return unit (6 pcs) |
| C | Attachment plate |
| D | Attachment screws M6x8 quality 8.8-A2F, Water and air unit (4 pcs) |

2 Installation

2.6.1. Installation of Water and air unit

Continued

Location of Water and air unit, type Sb (SpotPack Basic)

The Water and air unit type Sb is located as shown in the figure below. The figure shows the water and air unit fitted on IRB 6600, but the principle is the same for the other models.

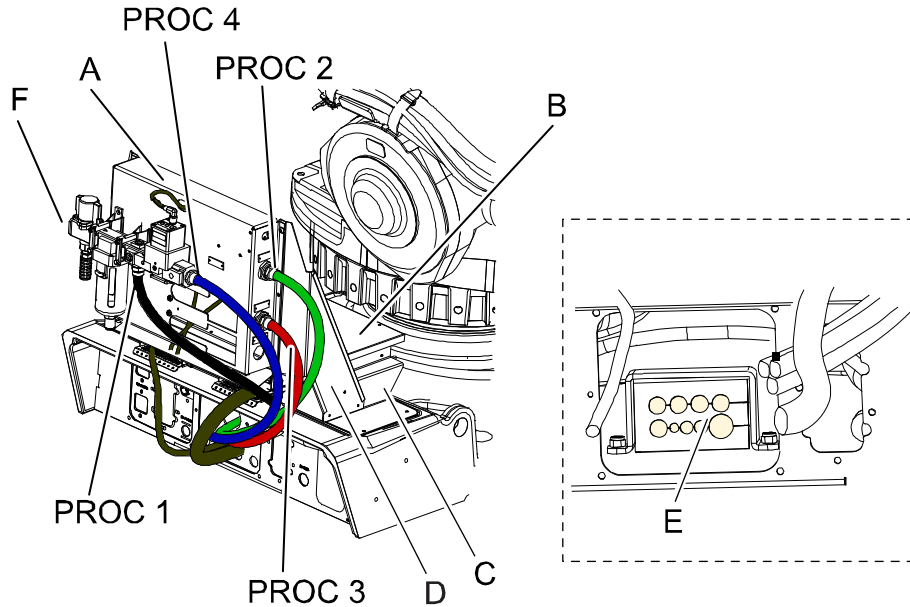

xx0800000115

| | |
|--------|--|
| A | Water and air unit, type Sb |
| B | Connection box |
| C | Bracket, connection box |
| D | Bracket right (Bracket left on other side. Not shown here) |
| E | Clamp holder with plastic clamp |
| PROC 1 | PROC 1 on robot base |
| PROC 2 | PROC 2 on robot base |
| PROC 3 | PROC 3 on robot base |
| PROC 4 | PROC 4 on robot base (option) |

General technical data, type S and Sb

The table below shows technical data of the water and air pressure:

| Parameter | Value |
|--------------------------|------------------------|
| Water operating pressure | Max. 0.6 MPa / 87 PSI |
| Air operating pressure | Max. 1.0 MPa / 145 PSI |

The table below shows technical data for water and air quality:

| Parameter | Value |
|---------------|---|
| Water quality | Normal filtered industrial water quality, 80 to 100 mesh. |
| Air quality | Use clean air. When there is excessive condensate, install a device that will eliminate water, such as a dryer or water separator (Drain Catch) on the inlet side of the air filter. |

© Copyright 2006-2010 ABB. All rights reserved.

Continues on next page

Continued

Required equipment

| Equipment, etc | Art. no. | Note |
|--------------------------------------|-------------------------------------|--|
| Water and Air unit, type S | See the <i>Spare parts</i> section. | A number of versions are available. |
| Water and air unit, type Sb | See the <i>Spare parts</i> section. | A number of versions are available. |
| Standard toolkit, DressPack/SpotPack | 3HAC17290-7 | The contents are defined in section Toolkits, DressPack/SpotPack on page 257 . |
| Circuit diagram | 3HAC026208-001 | SpotPack |

Installation of Water and air unit, type S

The procedure below details how to install the Water and Air unit, type S on the robot base.

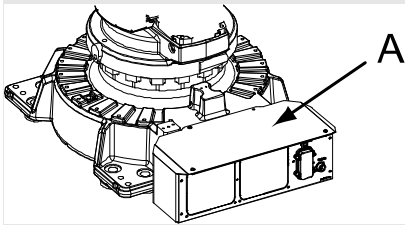
| Action | Note |
|---|--|
| <p>1.  DANGER! Turn off all electric power, hydraulic and pneumatic pressure supplies to the robot! For Foundry Prime robots: Do not turn off the air pressure to motors and SMB.</p> | |
| <p>2. Remove the attachment screws securing the <i>top cover</i> at the base of the robot. Keep the screws! They will be reused when fitting the water and air unit.</p> |  <p>xx0600003269</p> <p>Parts:</p> <ul style="list-style-type: none"> A: Top cover |
| <p>3. Fit the Water and Air unit and secure it with its attachment screws, M6x8 quality 8.8-A2F (4 pcs).</p> | <p>Reuse the screws of the top cover. Shown in the figure in section Location of Water and air unit, type S on page 115.</p> |
| <p>4. Connect the water and air supplies.</p> | <p>Specified in section Connections to Water and Air unit, type S on page 120 below.</p> |

2 Installation

2.6.1. Installation of Water and air unit

Continued

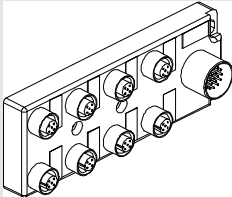
| | Action | Note |
|----|--|--|
| 5. | Connect the split box cable for Water and Air unit with the split box at the Water and Air unit. |  <p>xx0600003347</p> <p>Parts:</p> <ul style="list-style-type: none"> • Split box |

Installation of Water and air unit, type Sb

The procedure below details how to install the Water and Air unit, type Sb on the robot base.

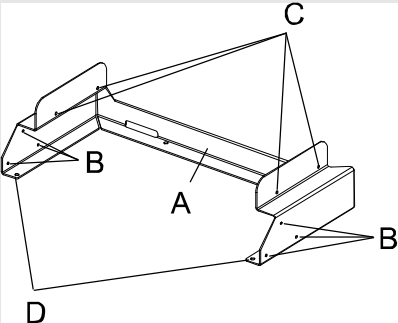
| | Action | Note |
|----|--|---|
| 1. |  <p>DANGER!</p> <p>Turn off all electric power, hydraulic and pneumatic pressure supplies to the robot!</p> <p>For Foundry Prime robots: Do not turn off the air pressure to motors and SMB.</p> | |
| 2. | Remove the attachment screws securing the top cover at the base of the robot. Keep the screws! They will be reused when fitting the water and air unit. | |
| 3. | Fit the <i>bracket connection box</i> using the attachment screws removed earlier. |  <p>xx0800000119</p> <p>Parts:</p> <ul style="list-style-type: none"> • A: Bracket connection box • B: Attachment holes for bracket left and right • C: Attachment holes for connection box • D: Attachment holes for securing to top cover |

© Copyright 2006-2010 ABB. All rights reserved.

Continues on next page

Continued

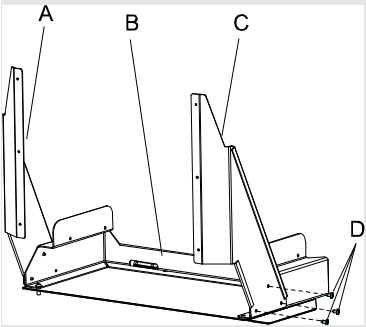
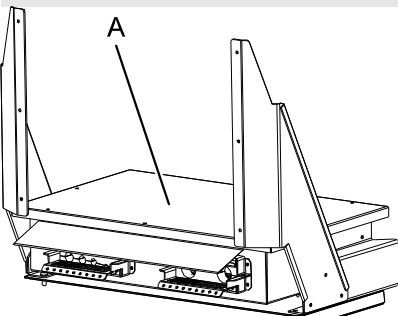
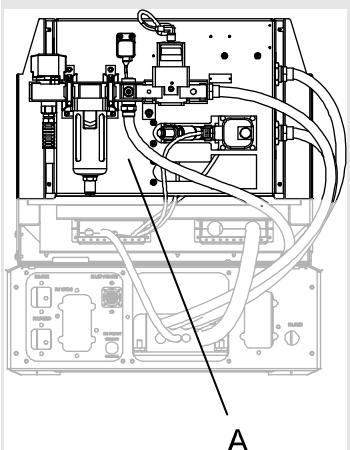
| | Action | Note |
|--|--|---|
| | <p>4. Fit the <i>bracket right</i> and <i>left</i> to the bracket connection box with its attachment screws.</p> |  <p>xx080000116</p> <p>Parts:</p> <ul style="list-style-type: none"> • A: Bracket left • B: Bracket connection box • C: Bracket right • D: Attachment screws |
| | <p>5. Fit the <i>connection box</i> to the brackets with its attachment screws.</p> | <p>The figure shows the connection box fitted on IRB 6640. The principle is the same on the other models.</p>  <p>xx080000120</p> <p>Parts:</p> <ul style="list-style-type: none"> • A: Connection box |
| | <p>6. Fit the <i>water and air unit</i> to the brackets with its attachment screws (Fastite).</p> |  <p>xx080000121</p> |

2 Installation

2.6.1. Installation of Water and air unit

Continued

Connections to Water and Air unit, type S

The figure below shows the connections at the robot base.

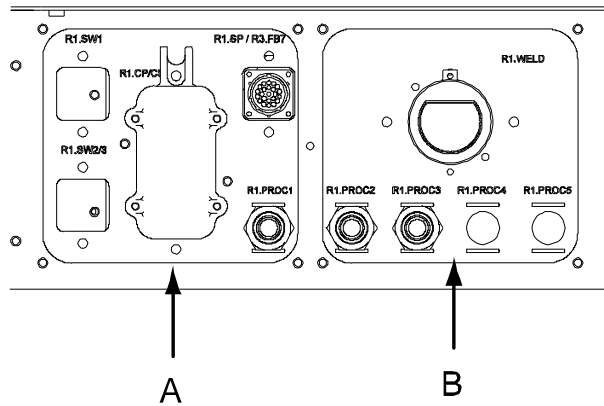

xx0600003178

| | |
|---|----------------|
| A | Customer plate |
| B | Process plate |

The figure below shows the connections on the Water and Air unit.

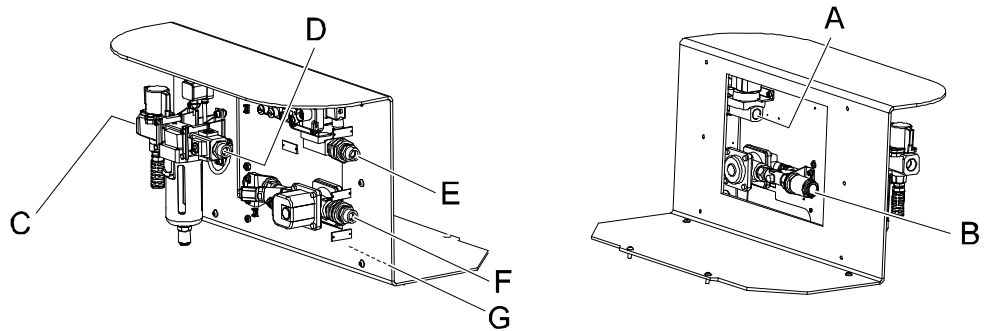

xx0600003270

| Item in figure | Connect to: | Function: |
|----------------|--|--|
| A | Shop water supply | |
| B | Shop water drain Note! In case of a second water return, the water drain connection is moved to the outside of the mounting plate! | |
| C | Shop compressed air supply | |
| D | PROC1 on robot base | Compressed air supply to robot |
| E | PROC2 on robot base | Water in circuit |
| F | PROC3 on robot base | Water return circuit |
| G | PROC4 on robot base Note! Only the position of this connection is shown in the figure! | Depending on option selected: <ul style="list-style-type: none"> • Second water return • Regulated air |

© Copyright 2006-2010 ABB. All rights reserved.

Continues on next page

Continued

Connections to Water and Air unit, type Sb

The figure below shows the connections at the robot base.

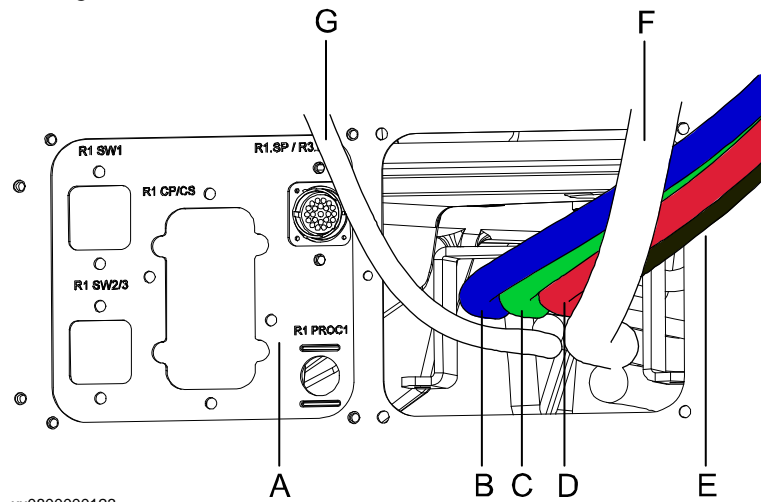

xx0800000123

| | |
|---|----------------|
| A | Customer plate |
| B | R1.PROC 1 |
| C | R1.PROC 2 |
| D | R1.PROC 3 |
| E | R1.PROC 4 |
| F | WELD |
| G | R1.CP/CS |

The figure below shows the connections on the Water and air unit.

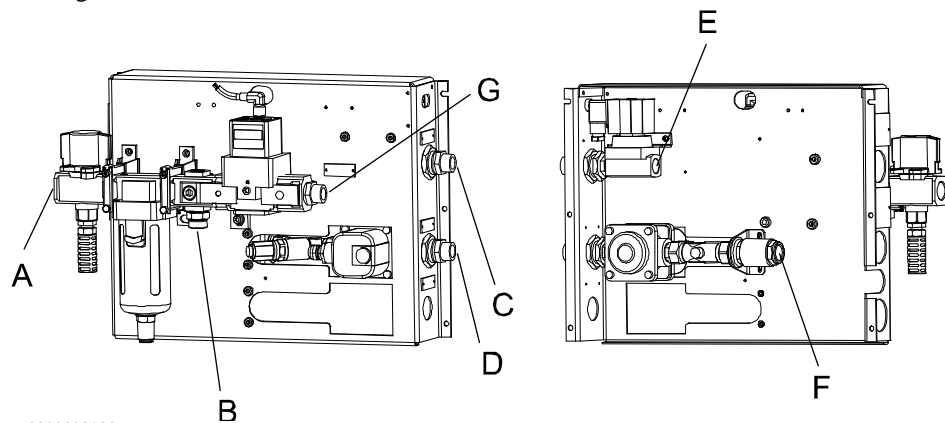

xx0800000122

| Item | Connect to: | Function: |
|------|------------------------------|---|
| A | Shop compressed air supply | |
| B | PROC 1 on robot base | Compressed air supply to robot |
| C | PROC 2 on robot base | Water in circuit |
| D | PROC 3 on robot base | Water return circuit |
| E | Shop water supply | |
| F | Shop water drain | |
| G | PROC4 on robot base (option) | Depending on option selected: <ul style="list-style-type: none"> Regulated air |

Continues on next page

2 Installation

2.6.1. Installation of Water and air unit

Continued

Shop water supply

The procedure below details how to connect the Water and Air unit to the shop water supply.

| | Action | Note |
|----|---|--|
| 1. | Route the water supply hose through the upper hole in the mounting plate. | |
| 2. | Type S: Connect the hose to the fitting with a G½" thread on the solenoid valve (A). | Shown in the figure in section Connections to Water and Air unit, type S on page 120. |
| 3. | Type Sb: Connect the hose to the fitting with a G½" thread on the solenoid valve (C). | Shown in the figure in section Connections to Water and Air unit, type Sb on page 121. |

Shop compressed air supply

The procedure below details how to connect the Water and Air unit to the shop compressed air supply.

| | Action | Note |
|----|---|--|
| 1. | Type S: Connect the air hose to the fitting with a G½" thread on the air shut off valve (C). | Shown in the figure in section Connections to Water and Air unit, type S on page 120. |
| 2. | Type Sb: Connect the air hose to the fitting with a G½" thread on the air shut off valve (A). | Shown in the figure in section Connections to Water and Air unit, type Sb on page 121. |

Water drain connection, One water return

The procedure below details how to connect the water drain connection with one water return, to the Water and Air unit.

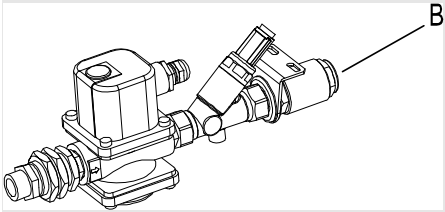
| | Action | Note |
|----|--|--|
| 1. | Route the water drain hose through the lower hole in the mounting plate. | |
| 2. | Connect the hose to the fitting with a G½" thread on the check-valve. |  <p>xx0600003348</p> <ul style="list-style-type: none"> • B: Water drain connection, one water return |

© Copyright 2006-2010 ABB. All rights reserved.

Continues on next page

Continued

Water drain connection, Two water return (Only applicable to type S)

The procedure below details how to connect the water drain connection with two water return, to the Water and Air unit.

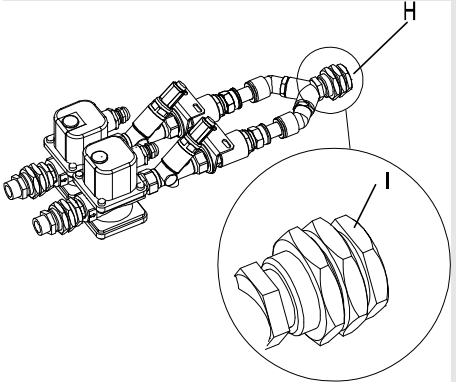
| Action | Note |
|---|---|
| <p>1. Connect the hose to the <i>bulkhead fitting</i> with a G½" thread.</p> <p> NOTE! Any rotation of the bulkhead fitting must be avoided when mounting. Hold the <i>outer part of the bulkhead fitting</i> with a suitable tool, in order to prevent rotation.</p> |  <p>xx0600003349</p> <p>Parts:</p> <ul style="list-style-type: none"> • H: Bulkhead fitting • I: Outer part of bulkhead fitting |

Hoses connecting Robot and Water and Air unit

The procedure below details how to connect hoses between robot and Water and Air unit.

| Action | Note |
|---|--|
| 1. Connect Proc 1 on the Water and Air unit with Proc 1 on the robot. | Shown in the figure in section Connections to Water and Air unit, type S on page 120 . Shown in the figure in section Connections to Water and Air unit, type Sb on page 121 . |
| 2. Connect Proc 2 on the Water and Air unit with Proc 2 on the robot. | Shown in the figure in section Connections to Water and Air unit, type S on page 120 . Shown in the figure in section Connections to Water and Air unit, type Sb on page 121 . |
| 3. Connect Proc 3 on the Water and Air unit with Proc 3 on the robot. | Shown in the figure in section Connections to Water and Air unit, type S on page 120 . Shown in the figure in section Connections to Water and Air unit, type Sb on page 121 . |
| 4. Connect Proc 4 on the Water and Air unit with Proc 4 on the robot. | If second water return is used. Shown in the figure in section Connections to Water and Air unit, type S on page 120 . Shown in the figure in section Connections to Water and Air unit, type Sb on page 121 . |
| 5. Secure all connectors. | See Tightening torques in section Screw joints on page 253 . |

2 Installation

2.6.2. Return water flow control

2.6.2. Return water flow control

Overview

The mechanical flow control valve is pre-set at delivery at 8 liter/min (maximum flow).

Settings

The procedure below details how to set the mechanical flow control valve.

| | Action | Note |
|----|--|---|
| 1. | Open the solenoid valve on the water inlet. | |
| 2. | Water flow is indicated on the scale of the Flow control valve. | |
| 3. | Adjust water flow by using the red adjusting knob on the scale of the Flow control valve to the required set flow. | The red adjusting knob is placed on the back of the Water and Air unit. |



2.6.3. Return water flow switch setting

Introduction

The mechanical flow switch is pre-set at delivery to 8 liters/min at 0.2 MPa water pressure. If the water pressure exceeds 0.2 MPa, the setting cannot be done with the graduation on the window name plate, as the pressure affects the measured flow. Please perform the setting as described in the following procedure.

Settings

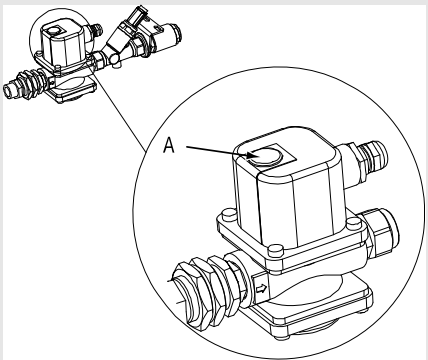
The procedure below details how to set the mechanical flow switch.

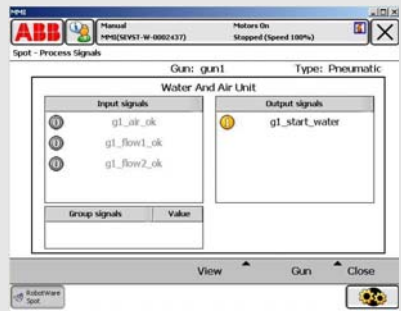
| | Action | Note |
|----|--|--|
| 1. | Open the solenoid valve on the water inlet. | |
| 2. | Water flow is indicated on the scale of the flow control valve. | |
| 3. | Adjust the water flow to the level where the Flow switch shall give alarm. Use the red adjusting knob on the scale of the flow control valve. | Detailed in section Return water flow control on page 124 . |
| 4. | <p>To adjust the set flow on the mechanical Flow switch, remove the grommet on the upper cover and rotate the flow adjusting gear by using a flat screwdriver.</p> <p>Turning clockwise will increase the set flow and turning counterclockwise will decrease the set flow.</p> |  <p>xx0600003346</p> <p>Parts:</p> <ul style="list-style-type: none"> A: Flow switch |
| 5. | <p>Depending on initial value, increase or decrease the set value until the g_flow_ok changes, by observing the <i>Process Signals window</i> on the Robot Teach Pendant.</p> <p> NOTE!</p> <p>The indicated flow level may differ from real flow as the flow switch is affected by the water pressure.</p> |  <p>xx0600003355</p> <ul style="list-style-type: none"> Process Signals window |
| 6. | Refit the grommet on the flow switch. | |

2 Installation

2.6.3. Return water flow switch setting

Continued

| | Action | Note |
|----|---|--|
| 7. | Increase water flow to desired level by adjusting the flow control valve. Put back the red adjusting knob on the back of the Water and Air unit. |  NOTE! This level shall be higher than the alarm level. |

2.6.4. Setting of Air pressure switch (Only applicable to type S)

General

The digital pressure switch monitors the shop floor air pressure.

Settings

The procedure below details how to set the digital pressure switch. The example shows how to set according to the pre-set values. The sensor will set **g1_air_ok** in the robot controller when pressure reaches 0.5 MPa and reset **g1_air_ok** if pressure goes lower than 0.45 MPa.

| | Mode | Action | Note |
|----|---|---|--|
| 1 | Preparation | Make sure that the pressure switch is connected to 12-24 VDC power. | |
| 2 | Initialize | In measurement mode, press SET button for two seconds or more. | 0 |
| 3 | Selection of Unit | Press UP or DOWN button until the display matches the figure on the right, then press the SET button. | PA PA indicates MPa. |
| 4 | OUT1 Output type Setting | Press UP or DOWN button until display matches the figure on the right, then press the SET button. | 1no ("1no" = Output 1 normally open) |
| 5 | OUT2 Output type Setting | Ignore and press the SET button. | 2n* |
| 6 | Response Time Setting | Press UP or DOWN button until display matches the value on the right, then press the SET button. | 24 |
| 7 | Auto/Manual Setting | Press UP or DOWN button until display matches the value on the right, then press the SET button. | nAn (nAn indicates manual setting) |
| 8 | Value Setting | In measurement mode, press the SET button. | |
| 9 | Set Point Value for OUT1(1) Pressure OK goes high | When the display blinks, press UP or DOWN button without pressing the SET button. Press UP or DOWN button until the display matches the value on the right, then press the SET button. | P_1 0.500 |
| 10 | Set Point Value for OUT1(2) Pressure OK goes low | When the display blinks, press UP or DOWN button without pressing the SET button. Press UP or DOWN button until the display matches the value on the right, then press the SET button. | P_2 0.450 |
| 11 | Set Point Value for OUT2(1) | Ignore and press the SET button. | P/n3 |
| 12 | Set Point Value for OUT2(2) | Ignore and press the SET button. | P/n4 |
| 13 | | The pressure switch changes to measurement mode. All settings are completed. | 0 |
| 14 | Zero Clear Function | Press UP and DOWN buttons simultaneously for about 2 seconds, under atmospheric pressure. | 0 |

2 Installation

2.6.4. Setting of Air pressure switch (Only applicable to type S)

Continued

Pre-set values

| Parameter | Pre-set value |
|--------------------|---------------|
| Unit specification | MPa |
| Hysteresis mode | Normally open |
| Response time | 24 ms |
| High pressure P_1 | 0.5 MPa |
| Low pressure P_2 | 0.05 MPa |

2.7 Spot welding cabinet

2.7.1. Lifting the Spotwelding Cabinet

General

The spotwelding cabinet is usually fitted on top of a IRC5 Controller on delivery, but it also possible to refit it to an existing controller cabinet. This procedure details how to lift the spotwelding cabinet.

Lifting

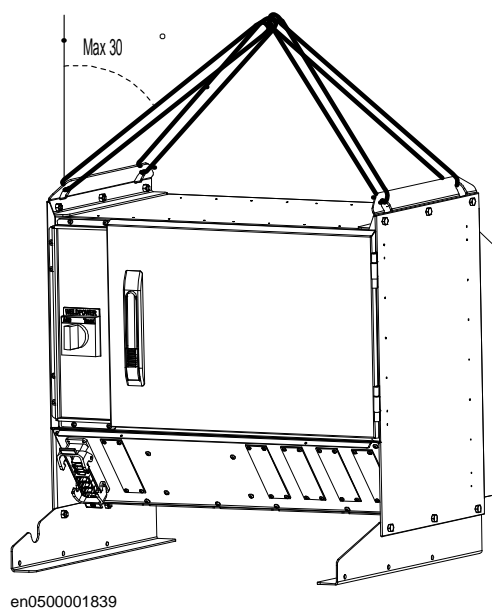

en0500001839

Procedure



WARNING!

The spotwelding cabinet may be lifted separately or fitted to the top of the IRC5 Controller. Use a suitable lifting device to avoid injury to personnel!



| | Action | Note |
|----|--|--|
| 1. | Fit the slings to the spotwelding cabinet's lifting eyes. | Make sure that the capacity of the slings matches the weight of the Cabinet/Controller with spotwelding cabinet. |
| 2. | Gently stretch the slings to take up the slack before lifting. | |

Continues on next page

2 Installation

2.7.1. Lifting the Spotwelding Cabinet

Continued

| | Action | Note |
|----|--|------|
| 3. |  CAUTION! The complete spotwelding cabinet weighs 60 kg without any additional equipment fitted. Use a suitable lifting device to avoid injury to personnel!  NOTE! If the spotwelding cabinet is lifted together with the Controller, the extra weight of the Controller must be taken in consideration! Use a suitable lifting device to avoid injury to personnel! | |
| 4. | Lift and move the spotwelding cabinet or the Controller with spotwelding cabinet, to its intended position. | |

2.7.2. Installation of Spotwelding Cabinet

Location of spotwelding cabinet

The spotwelding cabinet is located as shown in figure below.

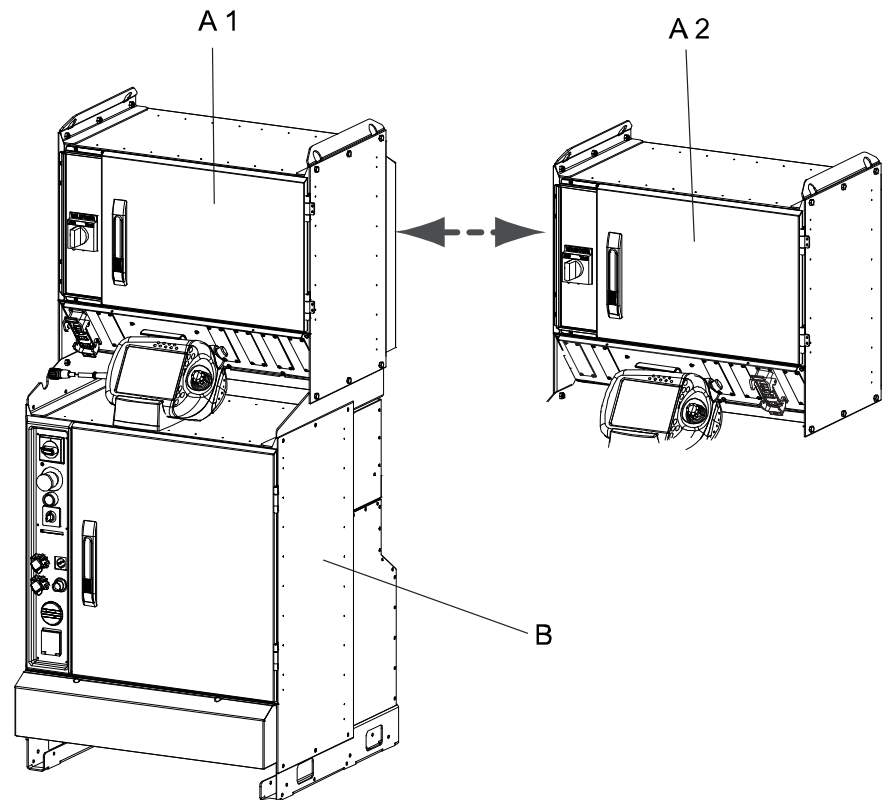

xx0800000114

| | |
|-----|-------------------------------------|
| A 1 | Spotwelding cabinet, standard |
| A 2 | Spotwelding cabinet, SpotPack Basic |
| B | Single cabinet controller |

Required equipment

| Equipment. | Art.no. | Note. |
|---------------------------------------|----------------------------------|---|
| Standard Tool kit, DressPack/SpotPack | 3HAC17290-7 | The contents are defined in section Toolkits, DressPack/SpotPack on page 257. |
| Drill | - | |
| Circuit diagram | 3HAC026136-001 3HAC026208-001 | Dress Pack SpotPack |



WARNING!

During installation of spotwelding cabinet:

- Do not remove the lifting slings from the spotwelding cabinet before securing it with the six screw joint reinforcement.

During removal of spotwelding cabinet:

- Never remove the six screw joint reinforcement without securing the spotwelding cabinet with lifting slings.

Continues on next page

2 Installation

2.7.2. Installation of Spotwelding Cabinet

Continued

Installation

The procedure in this section details how to install the spotwelding cabinet on top of the Single Cabinet Controller and secure it.

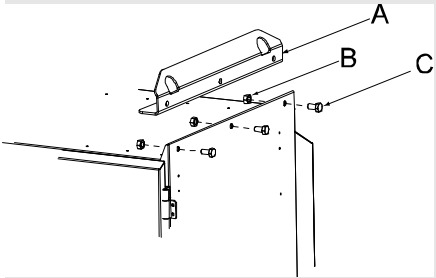
| Action | Note |
|---|--|
| 1.  DANGER! Before any work inside the cabinet, please observe the safety information in the section <i>DANGER - Make sure that the main power has been switched off</i> in the Product manual for the controller cabinet IRC5! | |
| 2. Remove the two <i>lift beams</i> , by loosening the six screw joint reinforcement. Use two ring wrenches size 13. |  en0500001856 Positions: <ul style="list-style-type: none">• A: 2x Lift beam• B: 6x M6M Nut M8• C: 6x Screw M6S M8x16 |
| 3. Follow instructions for lifting as detailed in the chapter Lifting spotwelding cabinet. | Detailed in section Lifting the Spotwelding Cabinet on page 129 |

Continued

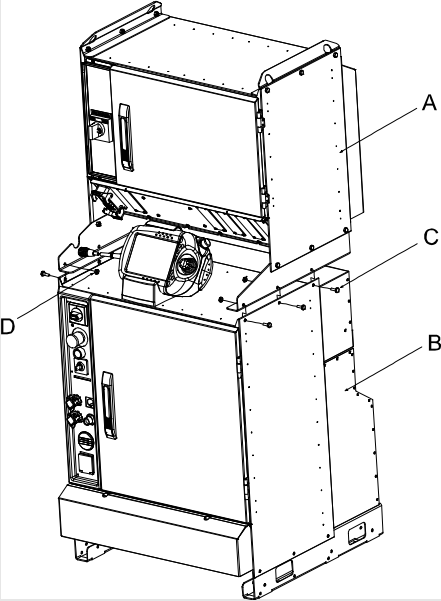
| | Action | Note |
|----|---|---|
| 4. | Secure the spotwelding cabinet on top of IRC5 controller with the six screw joints. | <p>The figure shows the spotwelding cabinet, standard.</p>  <p>en0500001857</p> <ul style="list-style-type: none"> • A: Spotwelding cabinet • B: Single cabinet controller • C: 6x Screw M6S M8x16 • D: 6x M6M Nut M8 |
| 5. | Make all power and signal connections as specified in the Circuit Diagram. | Specified in section Required equipment on page 131 . |

2 Installation



2.7.2. Installation of Spotwelding Cabinet

Continued

Connection

The following procedures details how to connect the power and signals to the spotwelding cabinet.

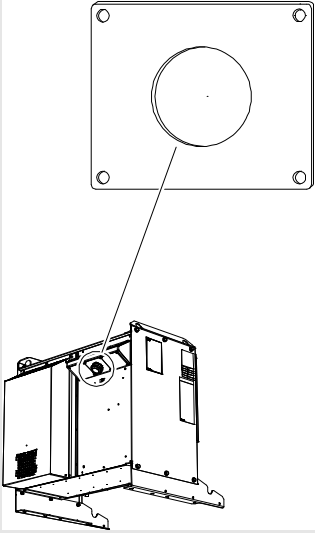
For connections in IRC5 controller, see *Installation of add-ons, Product manual IRC5*.

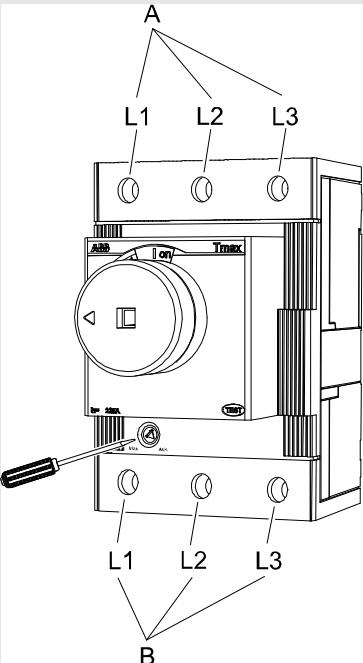
| Action | Note |
|---|--|
| <p>1. Drill a hole for cable gland in one of the covers on the rear plate.</p> <p></p> <p>NOTE! Locknut maximum width Ø60mm.</p> |  <p>xx0500002521</p> |
| <p>2. Fit the cable gland.</p> <p>3. Connect the incoming power.</p> <p></p> <p>NOTE! Max wire range:</p> <ul style="list-style-type: none">• 3 x 70 mm² T1• 3 x 95 mm² T2• 3 x 185 mm² T3 |  <p>xx0500002522</p> <ul style="list-style-type: none">• A: Incoming power• B: Outgoing power |

© Copyright 2006-2010 ABB. All rights reserved.

Continued

| | Action | Note |
|----|--|--|
| 4. | Check that the breaker is correctly adjusted for the weld timer mounted in the spotwelding cabinet. The T1 breaker is by default adjusted to 110 A (min.) | See weld timer types in, Replacement of Weld Timer on page 223 . |
| 5. | (Not applicable to SpotPack Basic) Connect harness connector (XS113) from the IRC5 controller to connector (XT113) on the spotwelding cabinet. | |

Earth fault protection

This section is not applicable to SpotPack Basic.

The installation must be fitted with some sort of earth fault protection **if any local regulations require this**.

This may be integrated with the spotwelding cabinet itself (option available from ABB), or be installed on the external shop power supply. If an alternative other than the one available from ABB is chosen, the **local installer is responsible** for the compliance to any national or international standards and regulations.

Three different installation alternatives a), b) and c) are specified in the illustration below:

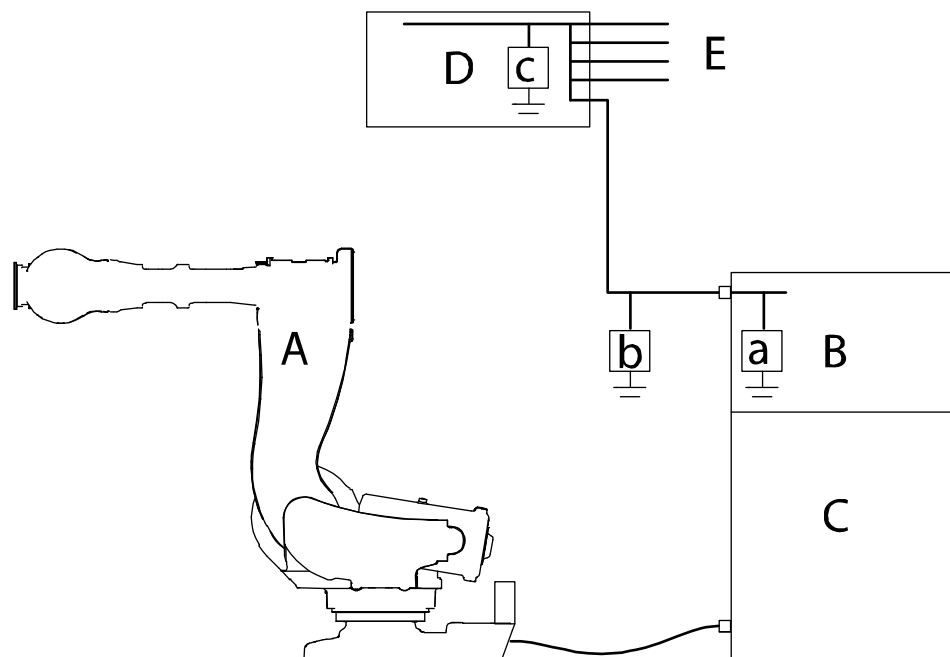

xx0300000175

| | |
|---|---|
| A | Robot |
| B | Spotwelding cabinet |
| C | Controller cabinet |
| D | External shop power supply (by customer/user) |
| E | Equipment group, supplied by external shop power supply |
| a | Integrated earth fault protection |
| b | External earth fault protection for the spotwelding cabinet <i>only</i> |
| c | External earth protection for equipment group including the spotwelding cabinet |

Continues on next page

2 Installation

2.7.2. Installation of Spotwelding Cabinet

Continued

The table below details the requirement specification regarding the earth fault protection:

| | |
|----------------------|-------------------------|
| Voltage, AC welder | 400 - 600 VAC, 50/60 Hz |
| Voltage, MFDC welder | 400 - 480 VAC, 50/60 Hz |
| Current | 110 A, RMS |

Contactor

This section is not applicable to SpotPack Basic.

The installation **may** be fitted with some sort of contactor (electro-mechanical disconnector):

- if any local regulations require this
- to protect any personnel working with the equipment
- to protect any parts of the equipment
- to enable monitoring of system status POWER ON.

This may be integrated with the spotwelding cabinet itself (option available from ABB), or be installed on the external shop power supply. If an alternative other than the one available from ABB is chosen, the **local installer is responsible** for the compliance to any national or international standards and regulations.

Three different installation alternatives a), b) and c) are specified in the illustration below:

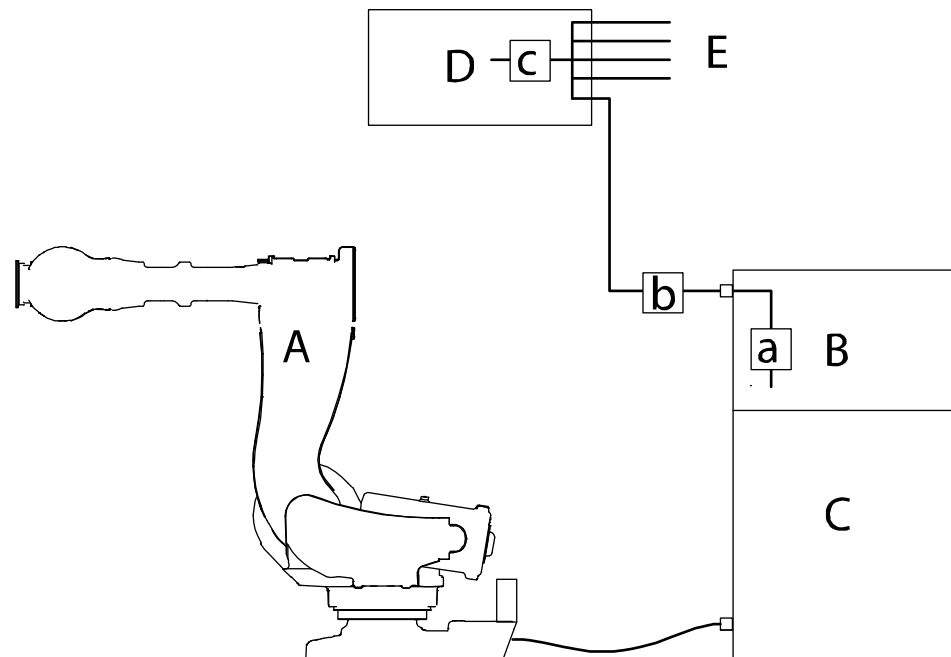

xx0300000177

| | |
|---|--|
| A | Robot |
| B | Spotwelding cabinet |
| C | Controller cabinet |
| D | External shop power supply (by customer/user) |
| E | Equipment group, supplied by external shop power supply |
| a | Integrated contactor |
| b | External contactor for the spotwelding cabinet <i>only</i> |
| c | External contactor for equipment group including the spotwelding cabinet |

© Copyright 2006-2010 ABB. All rights reserved.

Continues on next page

Continued

The table below shows the requirement specification regarding the contactor:

| | |
|----------------------|-------------------------|
| Voltage, AC welder | 400 - 600 VAC, 50/60 Hz |
| Voltage, MFDC welder | 400 - 480 VAC, 50/60Hz |
| Current | 110 A, RMS |

2 Installation

2.8.1. Installation of Tipdresser (option)

2.8 Installation of Tipdresser

2.8.1. Installation of Tipdresser (option)

Overview



NOTE!

The following general information about the tipdresser is important to notice:

- Tipdresser is not available as standard! It may be ordered as an option.
- Cutterholders are not included!
- What cutterholder to use depends on what weldgun tips are used.
- Cutterholders must be ordered separately!
- Software to the Tipdresser is not supplied by ABB Robotics.
- Use the following email address for more information about the tipdresser:
products.olofstrom@se.abb.com

Intended use

The Tipdresser is used to form electrodes. It is intended to restore the original shape of the welding electrodes after the deformation that occurs after a period of use.

The Tipdresser is intended to be integrated into the existing spotwelding cabinet.

Continued

Location of Tipdresser

The Tipdresser is located in one of the four corners of the robot base. It can be fitted in different positions depending on use. The figure below shows an example.

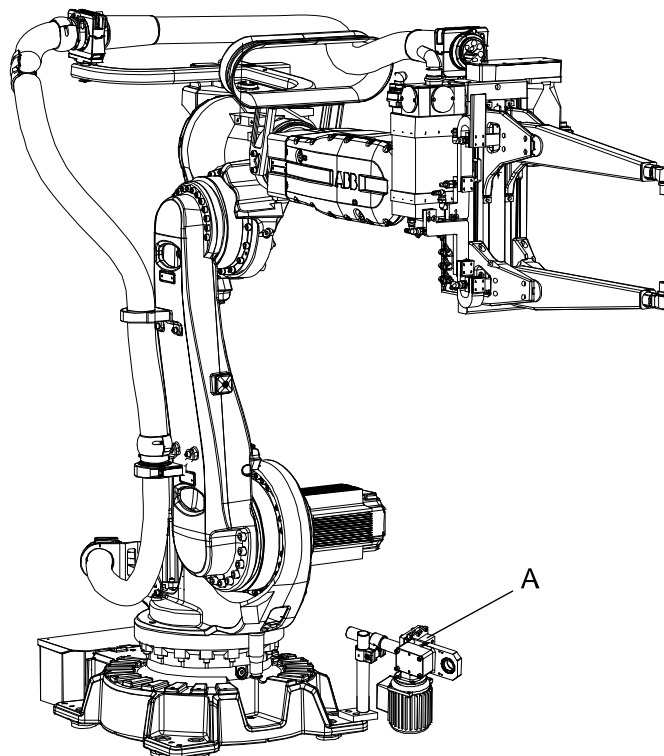

xx0600003202

| | |
|---|------------|
| A | Tipdresser |
|---|------------|

Description of electrical functionality

The flowchart below describes the electrical functionality of the Tipdresser.

- QB101 = Circuit breaker
- MS101 = Motor starter
- K103 = Contactor
- SWC = Spotwelding Cabinet

Continues on next page

2 Installation

2.8.1. Installation of Tipdresser (option)

Continued

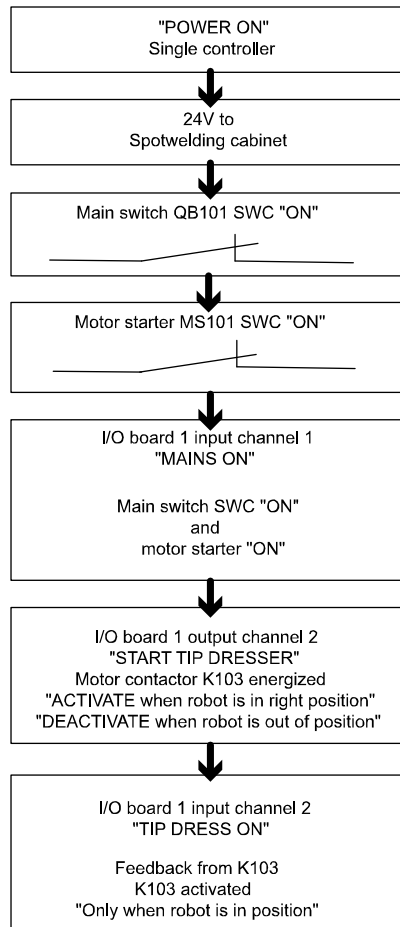

xx0600003196



Procedure

The procedure below details how to fit the Tipdresser to the robot base.

NOTE!

The integration of the Tipdresser shall be performed by the user!



| | Action | Note |
|----|---|------|
| 1. |  DANGER! Turn off all electric power, hydraulic and pneumatic pressure supplies to the robot! For Foundry Prime robots: Do not turn off the air pressure to motors and SMB. | |
| 2. |  DANGER! Rotary cutters may cause injured fingers and hands. | |

Continues on next page

Continued

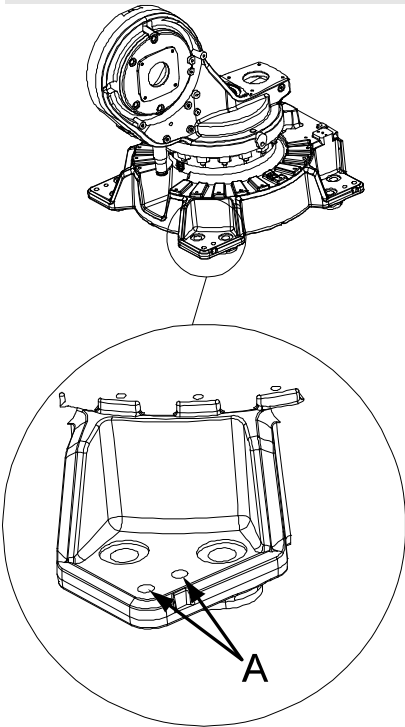
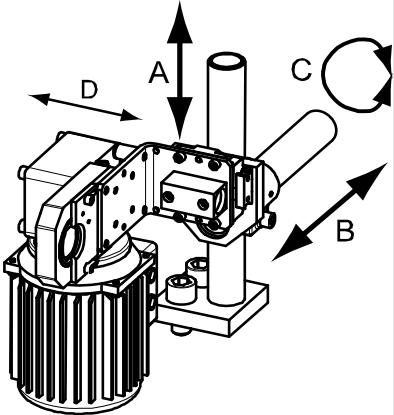
| Action | Note |
|---|---|
| <p>3. The Tipdresser is fitted on the robot base, in one of the four corners of the base.</p> <p> NOTE! Fork lifting pockets must be removed before fitting the Tipdresser!</p> |  <p>xx0600002927</p> <ul style="list-style-type: none"> • A: Attachment holes for Tipdresser |
| <p>4. Fit the Tipdresser with M20x40 screws (2 pcs) in the holes intended for forklift pockets.</p> | <p>Tightening torque: 300 Nm</p> |
| <p>5. It is possible to fit the Tipdresser in several positions. See figure to the right!</p> | <p>The figure below shows within what limits the Tipdresser can be fitted:</p>  <p>xx0600003197</p> <ul style="list-style-type: none"> • A: Adjustable ± 120 mm • B: Adjustable ± 98 mm • C: Turnable 360° • D: Equalizing ± 8 mm |
| <p>6. Fit the Tipdresser on its holders in such a position that it will function as supposed with the spotwelding tool used.</p> | |

Continues on next page

2 Installation

2.8.1. Installation of Tipdresser (option)

Continued

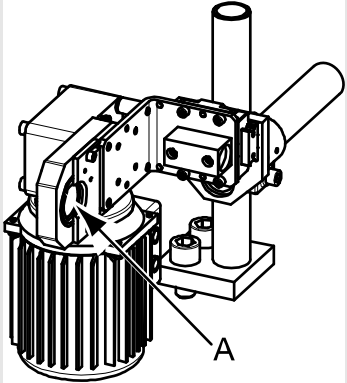
| | Action | Note |
|-----|---|--|
| 7. | Connect the Tipdresser cable to the its motor. | |
| 8. | Connect the Tipdresser cable to the spotwelding cabinet, connector XS105. | |
| 9. | Arrange the cable from the Tipdresser to the spotwelding cabinet in a secure way that it does not get damaged while the robot is in motion. | |
| 10. | <p>Fit the cutterholder on the Tipdresser.</p> <p> NOTE! Cutterholder must be ordered separately!</p> |  <p>xx0600003198</p> <ul style="list-style-type: none">• A: Place for cutterholder |

3 Maintenance

3.1. Introduction

Structure of this chapter

This chapter details all maintenance activities recommended for the manipulator.

It is based on the maintenance schedule located at the beginning of the chapter. The schedule contains information about required maintenance activities including intervals and refers to procedures for the activities.

Each procedure contains all the information required to perform the activity, that is, required tools and materials.

The procedures are gathered in different sections and divided according to the maintenance activity.

Safety information

Before any service work is commenced, it is extremely important that all safety information is observed!

There are general safety aspects that must be read through, as well as more specific safety information that describes the danger and safety risks when performing the procedures. Read the chapter *Safety* before performing any service work.



NOTE!

If the robot is connected to power, always make sure that the robot is connected to *earth* before starting any maintenance work!

For more information see:

- Product manual - IRC5
- Product manual - IRC5 Compact
- Product manual - Panel Mounted Controller

3 Maintenance

3.2.1. Maintenance schedule, SpotPack

3.2 Maintenance schedule and component lives

3.2.1. Maintenance schedule, SpotPack

General

The DressPack must be maintained regularly to ensure its function. The lifetime of a process cable package can be extended with the correct preventive maintenance activities. A daily visual check of the DressPack is highly recommended, which is normally performed by robot production personnel. It is essential that the person performing the visual check have basic training in ABB DressPack.

Wear parts

Wear parts should be replaced before considerable damage occurs to the process cable package. Replace wear parts before the part is completely damaged.

The following parts are considered as wear parts:

- Protection sleeves
- Protective hose
- Hose reinforcement
- Slide sleeves
- Damper

Activities and intervals, standard equipment

The sections referred to in the table can be found in the different chapters for each maintenance activity.

The table below specifies the required maintenance activities and intervals:

| Maintenance activity | Equipment | Interval | Detailed in section: |
|----------------------|--------------------------|--------------|---|
| Inspection | Water & Air unit | 1 month | Preventive inspection of Water and air unit on page 155 |
| Inspection | Spotweldning cabinet | Regularly *) | Preventive inspection of Spotweldning Cabinet on page 158 |
| Replacement | Bosch weld timer battery | 2 years | Replacement of Bosch weld timer battery on page 227 |
| Inspection | All cables | Regularly *) | Preventive inspection of all cables, SpotPack on page 146 |
| Inspection | DressPack cable package | Regularly *) | Preventive inspection, DressPack upper end on page 148 |
| Cleaning | DressPack cable package | Regularly *) | Cleaning, DressPack upper arm on page 161 |
| Cleaning | Spotwelding cabinet | Regularly | Cleaning the Fan Unit on page 165 Cleaning the Weld Timer cooling fins on page 167 |

© Copyright 2006-2010 ABB. All rights reserved.

Continues on next page

Continued

| Maintenance activity | Equipment | Interval | Detailed in section: |
|----------------------|------------------|--------------|--|
| Cleaning | Water & Air unit | Regularly *) | Cleaning, Water and air unit on page 163 |

*) "Regularly" implies that the activity is to be performed regularly, but the actual interval may not be specified by the robot manufacturer. The interval depends on the operation cycle of the robot, its working environment and movement pattern.

Generally, the more contaminated the environment, the closer the maintenance intervals. Also, the more demanding the movement pattern (sharper bending cable harness), the closer the intervals.

Based on experience, some parts are more exposed to wear. Therefore the DressPack upper arm cable package should be inspected according to the following scheme.

| Interval | Action |
|---------------------------------|-----------------|
| Weekly | None |
| Every two weeks | Inspection wear |
| Every third month | Inspection |
| Every three years | Replace |
| After changing movement pattern | Inspection |

3 Maintenance

3.3.1. Preventive inspection of all cables, SpotPack

3.3 Inspection activities

3.3.1. Preventive inspection of all cables, SpotPack

Cables, in the SpotPack system

There are many different cables used in the SpotPack system. The different cables used, are listed in *Spare parts* section.

The inspection activities described below are a general description, and does not refer to any specific cable.

Required equipment

| Equipment | Art. no. | Note |
|--------------------------------------|-------------|--|
| Standard Toolkit, DressPack/SpotPack | 3HAC17290-7 | The contents are defined in section Toolkits, DressPack/SpotPack on page 257 . |

Inspection

The procedure below details how to inspect all cables included in the SpotPack system.

This instruction applies to:

- DressPack upper arm and cables and hoses contained within
- DressPack lower arm and cables and hoses contained within
- DressPack lower/upper arm and cables and hose contained within
- DressPack floor and cables and hoses contained within.

| | Action | Note |
|----|---|--|
| 1. |  DANGER! Turn off all electric power, hydraulic and pneumatic pressure supplies to the robot! For Foundry Prime robots: Do not turn off the air pressure to motors and SMB. | |
| 2. | Check that the unit is clean and not overly contaminated. | Clean if required as detailed in section Cleaning, DressPack upper arm on page 161 . |
| 3. | Check that all bolts are fastened. | Recommended tightening torques are specified in section Screw joints on page 253 . |
| 4. | Check that all connections are safely made. | Retighten if necessary. |
| 5. | Check that all hose connections are safely made and that there are no leaks. | Retighten if necessary. |

© Copyright 2006-2010 ABB. All rights reserved.

Continues on next page

Continued

| | Action | Note |
|----|---|--|
| 6. | Check for mechanical wear, especially in areas where the cable/hose package rub against or move close to the robot or any other structure. Especially check any cable/hose package at the robot wrist. | Replace any worn items as detailed in the Repair chapter. Readjust the assembly after installation. |
| 7. | If any of the protective sleeves are worn, rotate or replace. | Detailed in section Replacement of protective sleeves on page 192 . |
| 8. | Check the attachment of any cable/hose package to make sure they are properly secured. | Secure any loose items as detailed in the Installation chapter. |
| 9. | Check all cable retainers to make sure the cables/hoses are securely locked in the cable retainers. | Tighten any loose cable retainers as detailed in Repair of process cable package on page 195 . |

3 Maintenance

3.3.2. Preventive inspection, DressPack upper end

3.3.2. Preventive inspection, DressPack upper end

Location of DressPack upper end

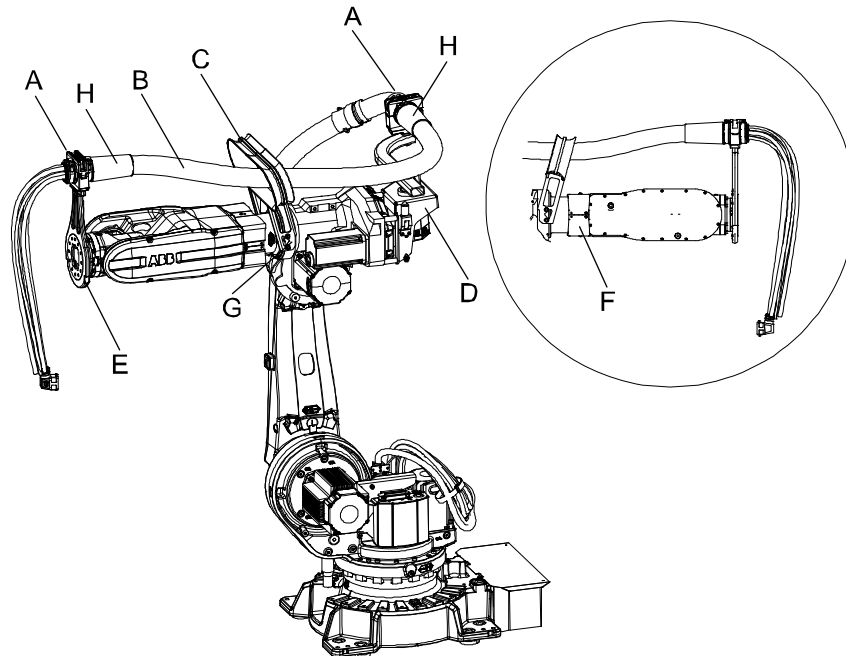

xx0600003149

The figure shows the upper arm part of cable package IRBDP MH 2 CE / IRBDP SW 2 CE.

| | |
|---|--|
| A | Ball joint housing |
| B | Process cable package |
| C | Hose support |
| D | Tension arm unit |
| E | Process cable support axis 6, complete |
| F | Arm protection |
| G | Bracket, hose support |
| H | Hose reinforcement |

Continued

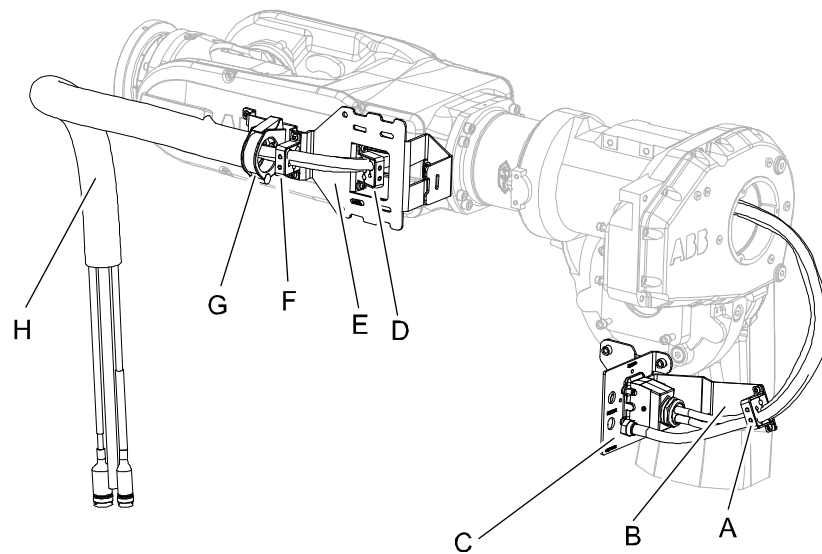

xx0700000580

The figure shows the cable package IRBDP MH 3 UE.

| | |
|---|---|
| A | Metal clamp with rubber clamp |
| B | Bracket for metal clamp |
| C | Connection plate, ax 3 (delivered with the cable package IRBDP MH 3 LE) |
| D | Metal clamp with rubber clamp (right) |
| E | Bracket at wrist |
| F | Metal clamp with rubber clamp (left) |
| G | Gripping clamp & clamp halves |
| H | Protection hose |

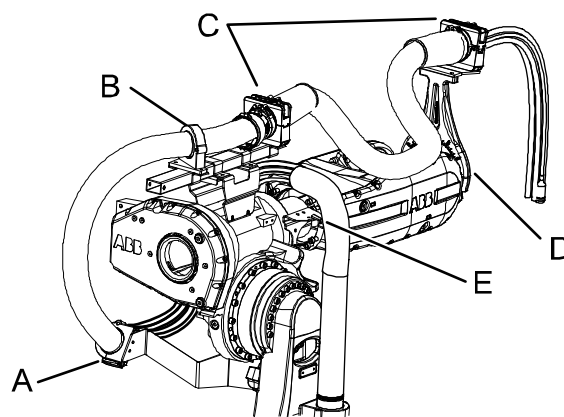

xx0800000112

The figure shows the cable package IRBDP SW 5 CE.

| | |
|---|-------------------------------------|
| A | Gripping clamp (axis 3 clamp mount) |
| B | Gripping clamp (adjustable bracket) |
| C | Ball joint housing |
| D | Process cable support axis 6 |
| E | Spiral hose bracket |

Continues on next page

3 Maintenance

3.3.2. Preventive inspection, DressPack upper end

Continued

Required equipment



| Equipment | Art. no. | Note |
|--|-------------|--|
| Standard Toolkit, DressPack/ SpotPack | 3HAC17290-7 | The contents are defined in section Toolkits, DressPack/SpotPack on page 257 . |

Inspection - Robot standing still

The procedure below details how to inspect the DressPack when the robot is not in motion.

| | Action | Note |
|----|---|---|
| 1. |  DANGER! Turn off all electric power, hydraulic and pneumatic pressure supplies to the robot! For Foundry Prime robots: Do not turn off the air pressure to motors and SMB. | |
| 2. | Check that the DressPack is not contaminated. | If required, clean as detailed in section Cleaning, DressPack upper arm on page 161 . |
| 3. | Check that all bolts are fastened. | Recommended standard tightening torques are specified in section Screw joints on page 253 . |

Continued

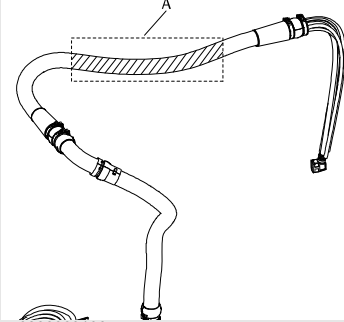
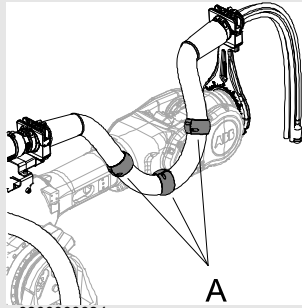
| Action | Note |
|---|--|
| <p>4. Check the position and state of the <i>protective sleeves</i>. Place these where they prevent the protection hose from rubbing against the upper arm of the robot, as much as possible.</p> <p> NOTE! When fitting several protective sleeves, always leave a space between them (approximately the width of one slide sleeve).</p> <p> NOTE! Protective sleeves are not available as standard! If required, protective sleeves may be fitted and can be ordered as spare part!</p> |  <p>xx0600003190</p> <p>Parts:</p> <ul style="list-style-type: none"> A: Area where protective sleeves may be fitted, if needed.  <p>xx0800000084</p> <p>IRBDP SW 5 CE</p> <p>Parts:</p> <ul style="list-style-type: none"> A: Protective sleeves <p>Make a note of where the protective sleeves were positioned to facilitate replacing them in the future. If required, replace the protective sleeves.</p> |
| <p>5. Make sure all cable straps are tight enough to prevent the cable package from moving in any undesired way.</p> | |
| <p>6. Make sure that the velcro strap not are too tight. The cables should be able to twist.</p> | |
| <p>7. Make sure that the cable package is properly connected at:</p> <ul style="list-style-type: none"> the connection plate the robot base the lower arm the tool on the turning disk of the robot. | |
| <p>8. Check that all connections are safely made and that there are no leaks.</p> | Retighten if necessary. |
| <p>9. Make sure the <i>hose package</i> is not cracked or damaged in any other way.</p> | Shown in the figure in section Location of DressPack upper end on page 148 . |

3 Maintenance

3.3.2. Preventive inspection, DressPack upper end

Continued

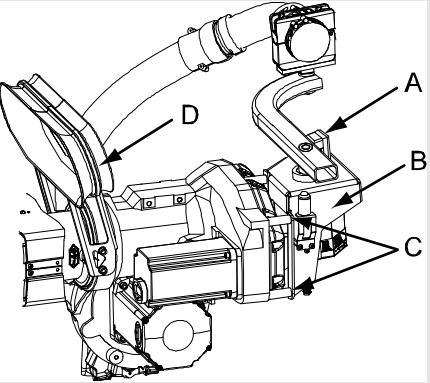
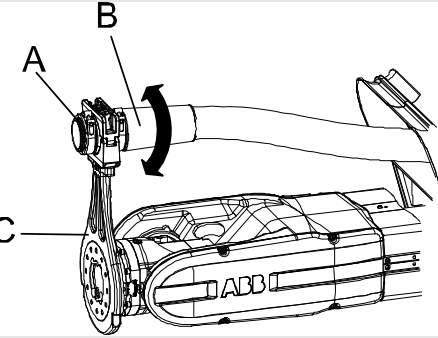
| | Action | Note |
|-----|---|--|
| 10. | <p>(Not applicable to cable package IRBDP MH 3 UE)</p> <p>Inspect the rubber <i>damper</i>. Make sure it is not chipped or damaged in any other way.</p> |  <p>xx0600003179</p> <p>Parts:</p> <ul style="list-style-type: none"> • A: Damper • B: Tension arm unit • C: Attachment screws (3 pcs) • D: Hose support <p>If required, replace the damper.</p> |
| 11. | <p>(Not applicable to cable package IRBDP MH 3 UE)</p> <p>Make sure the <i>sliding surfaces</i> at both ends of the slide sleeves (at the process cable support axis 6 as well as at the tension arm unit) has not been damaged or show excessive wear.</p> <p>Check this with normal hand force:</p> <ol style="list-style-type: none"> 1. grab hold of the package 2. pull and turn to make sure that the package is free to slide. <p>If the slide sleeves are too worn:</p> <ol style="list-style-type: none"> 1. disassemble and clean 2. replace. <p>Always make sure that the slide sleeves are clean! If they are dirty, clean them!</p> |  <p>xx0600003176</p> <p>Parts:</p> <ul style="list-style-type: none"> • A: Slide sleeve slide surface • B: Hose reinforcement • C: Process cable support axis 6 <p>A damaged surface may potentially prevent the cable package from rotating, thus causing excessive wear.</p> <p>Cleaning agent is specified in section Required equipment on page 150.</p> <p>If required, replace the slide sleeves as detailed in section Replacement of slide sleeves on page 208.</p> |

© Copyright 2006-2010 ABB. All rights reserved.

Continues on next page

Continued

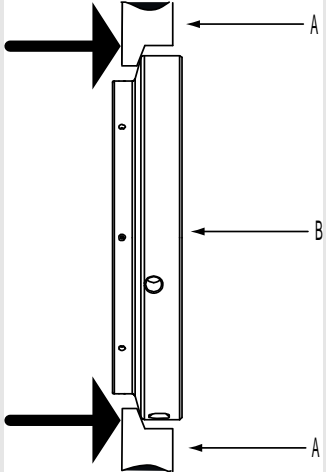
| | Action | Note |
|-----|---|---|
| 12. | <p>(Not applicable to cable package IRBDP MH 3 UE) Check that the process cable support axis 6 is fully pushed forward against the turning disk axis 6.</p> | <p>If needed, adjust tightening torque. Tightening torque: 70 Nm.</p>  <p>xx0400001040</p> <p>Parts:</p> <ul style="list-style-type: none"> • A: Process cable support axis 6 • B: Turning disk axis 6 |
| 13. | <p>(Not applicable to cable package IRBDP MH 3 UE) Visually inspect the <i>hose reinforcement</i> to make sure there are no cracks or other damage.</p> | <p>Shown in the figure in section Location of DressPack upper end on page 148. If required, replace the hose reinforcement as detailed in the section Replacement of hose reinforcement on page 205.</p> |
| 14. | <p>Check all cable clamps securing the process cable package and protective hose for tightness.</p> | <p>Tightening torques are specified either in:</p> <ul style="list-style-type: none"> • Installation chapter (non-standard tightening torques) or • standard tightening torque table (standard tightening torques). |

Inspection - Reduced speed

The following procedure details how to inspect the DressPack at the upper arm when the robot is moving in reduced speed.



WARNING!

A robot in motion is dangerous and may cause severe personal injuries, if safety procedures are not followed. Hence, all work must be performed outside the robots working range and outside the robots safety area.

Secure the following before work starts:

- Check that all emergency stops are fully functional.
- Close and activate all safety equipment (safety gates and/or safety curtains etc.).

| | Action |
|----|--|
| 1. | Make sure that no hoses or cables, or parts thereof, touch any part of the robot structure in a way that may cause wear. |
| 2. | Make sure all cables and hoses move smoothly together during operation and that no part of the cable package moves in a different pattern. |

Continues on next page

3 Maintenance

3.3.2. Preventive inspection, DressPack upper end

Continued

Inspection - Full speed

The following procedure details how to inspect the DressPack at the upper arm, when the robot is moving in full speed.



WARNING!

A robot in motion is dangerous and may cause severe personal injuries, if safety procedures are not followed. Hence, all work must be performed outside the robots working range and outside the robots safety area.

Secure the following before work starts:

- Check that all emergency stops are fully functional.
- Close and activate all safety equipment (safety gates and/or safety curtains etc.).

| | Action | Note |
|----|--|------|
| 1. | Make sure that no hoses or cables, or parts thereof, touch any part of the robot structure (or something in the vicinity of it) in a way that may cause wear. | |
| 2. | Make sure all cables and hoses move smoothly together during operation and that no part of the cable package moves in a different pattern. | |
| 3. | (Not applicable to cable package IRBDP MH 3 UE) Make sure that when the robot program is running, the movement of the tension arm unit shall be smooth, but still strong enough to retract the hose package without excessive force. | |

3.3.3. Preventive inspection of Water and air unit

Location of Water and air unit, type S

The Water and air unit is located as shown in the figure below.

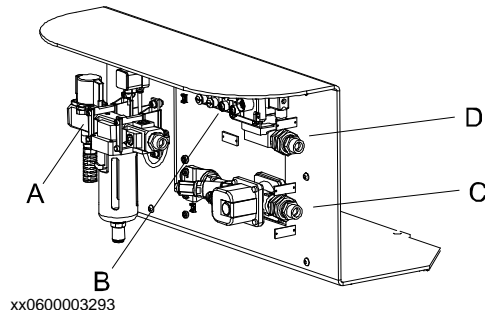

| | |
|---|----------------------|
| A | Air supply circuit |
| B | Split box |
| C | Water return circuit |
| D | Water in circuit |

Location of Water and air unit, type Sb

The Water and air unit is located as shown in the figure below.

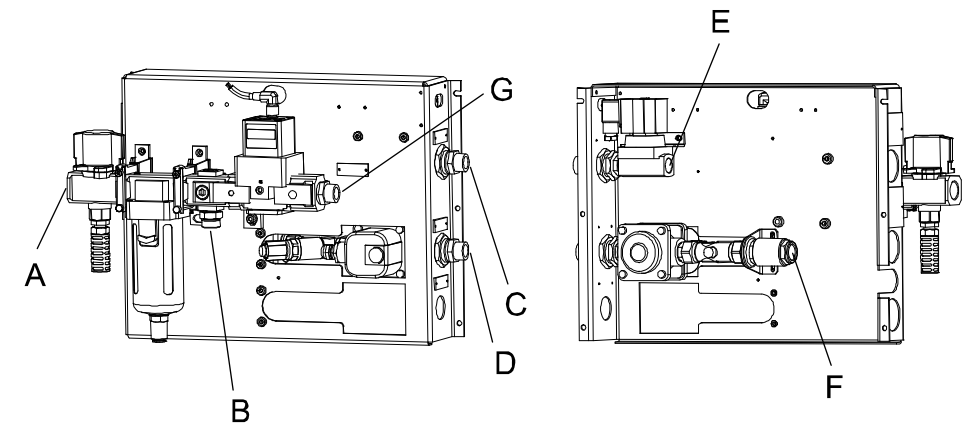

| | |
|---|-------------------------------|
| A | Shop compressed air supply |
| B | PROC 1 on robot base |
| C | PROC 2 on robot base |
| D | PROC 3 on robot base |
| E | Shop water supply |
| F | Shop water drain |
| G | PROC 4 on robot base (option) |

3 Maintenance

3.3.3. Preventive inspection of Water and air unit

Continued

Required equipment

| Equipment | Art. no. | Note |
|--|-------------|--|
| Standard Toolkit, DressPack/SpotPack | 3HAC17290-7 | The contents are defined in section Toolkits, DressPack/SpotPack on page 257 . |
| Other tools and procedures may be required. See references to these procedures in the step-by-step instructions below. | | These procedures include references to the tools required. |

General inspection

The procedure below details how to perform a general inspection of the Water and air unit.

| | Action | Note |
|----|---|---|
| 1. | Check that the Water and air unit is not contaminated. | Clean if required as detailed in section Cleaning, Water and air unit on page 163 . |
| 2. | Check that the bolts are fastened. | Recommended tightening torques are specified in section Tightening torque on page 254 . |
| 3. | Check that all connections are safely made and that there are no leaks. | Retighten if necessary! |

Inspection, air supply circuit

The procedure below details how to inspect the air supply circuit.

| | Action | Note |
|----|--|---|
| 1. | Check if there is water in the filter receptacle. Normally the filter receptacle is drained automatically in case of a fall of air pressure. If there is no fall of pressure in the air system, there is an automatic draining of the system, when the water level reaches a certain level. | If there is a lot of water in the filter receptacle, this is a sign that the supplied air consist of too much water. If this is the case, steps must be taken to correct this problem! |
| 2. | It is also possible to drain the air filter receptacle manually. This is done by pressing a small pin at the bottom of the air filter unit. | |
| 3. | Check that there is no leakage. | Retighten if necessary! |
| 4. | Check the condition of the air filter. | If needed replace the air filter. Normally the filter should be replaced after one year of use. |

© Copyright 2006-2010 ABB. All rights reserved.

Continues on next page

Inspection, water in and water return circuits

The procedure below details how to inspect the water in and water return circuits.

| | Action | Note |
|----|---|-------------------------|
| 1. | Open the hand operated ball valve for water inlet. | |
| 2. | Open the water return valve on the water in circuit. | |
| 3. | Close the hand operated ball valve for water outlet. | |
| 4. | While the system is under pressure, check if there are any leaks. | Retighten if necessary! |
| 5. | Reset the system. | |

3 Maintenance

3.3.4. Preventive inspection of Spotwelding Cabinet

3.3.4. Preventive inspection of Spotwelding Cabinet

Overview

The section below details and locates the different parts in the spotwelding cabinet and how to perform a preventive inspection.

Location of parts

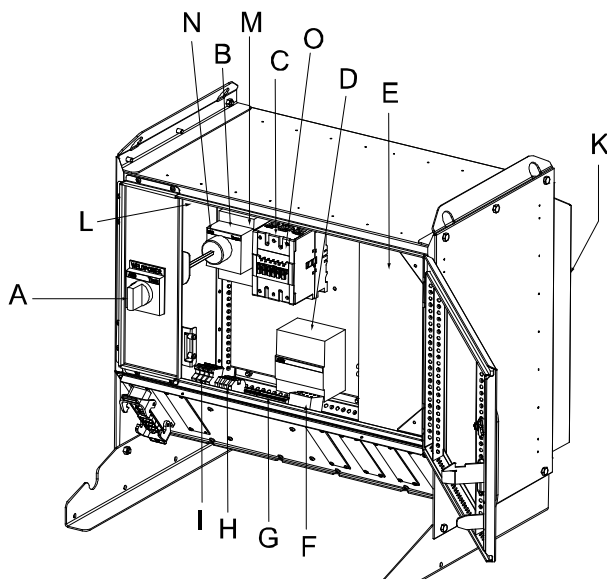

en0500001860

| | | |
|---|---|---------------------------|
| A | Main switch (weld power only) | Standard & SpotPack Basic |
| B | Circuit breaker, QB101 | Standard & SpotPack Basic |
| C | Welding contactor (Part of option "Contactor for welding power") | Standard |
| D | Residual current release (Available as option). Placement varies depending on version (AC or MFDC). This illustration shows MFDC. | Standard |
| E | Weld Timer, V101 | Standard & SpotPack Basic |
| F | Mini Contactor (Part of option "Contactor for welding power") | Standard |
| G | Harness terminal | Standard & SpotPack Basic |
| H | Bridge 4-pole | Standard & SpotPack Basic |
| I | Fuse terminal | Standard & SpotPack Basic |
| K | Fan unit (Available as option). Note! Version MFDC is already equipped with fan when delivered. Placement at the back of the spotwelding cabinet. FU100 | Standard & SpotPack Basic |
| L | Earth bar | Standard & SpotPack Basic |
| M | Auxiliary contact (part of option "Contactor for weld power") | Standard |
| N | Shunt trip, 24V or 120V (not available with option "External residual current release") | Standard |
| O | Surge suppressor | Standard |

© Copyright 2006-2010 ABB. All rights reserved.

Continues on next page

Required equipment

| Equipment | Art. no. | Note |
|--|-------------|--|
| Standard toolkit DressPack/ SpotPack | 3HAC17290-7 | The contents are defined in section Toolkits, DressPack/SpotPack on page 257 . |
| Multimeter | - | For measuring resistance. |
| Other tools and procedures may be required. See references to these procedures in the step-by-step instructions below. | | These procedures include references to the tools required. |

General inspection

The procedure below details how to perform a general inspection of the spotwelding cabinet, that is the inspection not pertaining to any particular part.

| | Action | Note |
|----|--|---|
| 1. |  DANGER! Before any work inside the cabinet, please observe the safety information in the section <i>DANGER - Make sure that the main power has been switched off</i> in the Product manual for the controller cabinet IRC5. | |
| 2. | Check that the spotwelding cabinet is not contaminated. Especially check the fans and the welding guard for contaminants. | Clean if required. |
| 3. | Check that all bolts are fastened. | Recommended tightening torques are specified in section <i>Screw joints</i> . |
| 4. | Check that all connections are safely made and that no connectors are loose. | Retighten if necessary. |

Inspection, contactor, fuses and circuit breaker

The procedure below details how to inspect contactor (if included), fuses and circuit breaker in the spotwelding cabinet.

| | Action | Note |
|----|---|------|
| 1. |  DANGER! Before any work inside the cabinet, please observe the safety information in the section <i>DANGER - Make sure that the main power has been switched off</i> in the Product manual for the controller cabinet IRC5 | |
| 2. | Check settings. | |

Continues on next page

3 Maintenance

3.3.4. Preventive inspection of Spotwelding Cabinet

Continued

| | Action | Note |
|----|---|---------------------------------------|
| 3. | Check that the contactor is working. | Secure the function of the contactor. |
| 4. | Check fastening of fuse strips . | |
| 5. | Check function of circuit breaker . | |
| 6. | Check cable connections . | |

Inspection, residual current release

This section is not applicable to SpotPack Basic.

The residual current release unit is not a standard feature of the spotwelding cabinet! This instruction details how to inspect the optional residual current release unit fitted by ABB Robotics. Other residual current release units fitted by others require inspection as specified by that manufacturer respectively.

The procedure below details how to inspect the ABB Robotics residual current release unit.

| | Action | Note |
|----|---|--|
| 1. |  DANGER! Before any work inside the cabinet, please observe the safety information in the section <i>DANGER - Make sure that the main power has been switched off</i> in the Product manual for the controller cabinet IRC5 | |
| 2. | Test the function of the <i>residual current release</i> by pressing the button marked "TEST". The unit should trip causing the power supply to be interrupted. | If the result of the function test is not satisfactory, the residual current release switch should be replaced. This is detailed in section Replacement of external residual current release on page 242 . |

Inspection, fan unit

Fan unit is an option.

The procedure below details how to inspect the fan unit.

NOTE!

Version MFDC is already equipped with fan when delivered.



| | Action | Note |
|----|---|-----------------------------|
| 1. |  DANGER! Before any work inside the cabinet, please observe the safety information in the section <i>DANGER - Make sure that the main power has been switched off</i> in the Product manual for the controller cabinet IRC5 | |
| 2. | Check the function of the fan unit. | Listen for abnormal sounds. |
| 3. | Inspect the fan unit. | If necessary, clean! |

3.4 Cleaning activities

3.4.1. Cleaning, DressPack upper arm

Overview

This section is not applicable to cable package IRBDP MH 3 UE.

Location DressPack upper arm

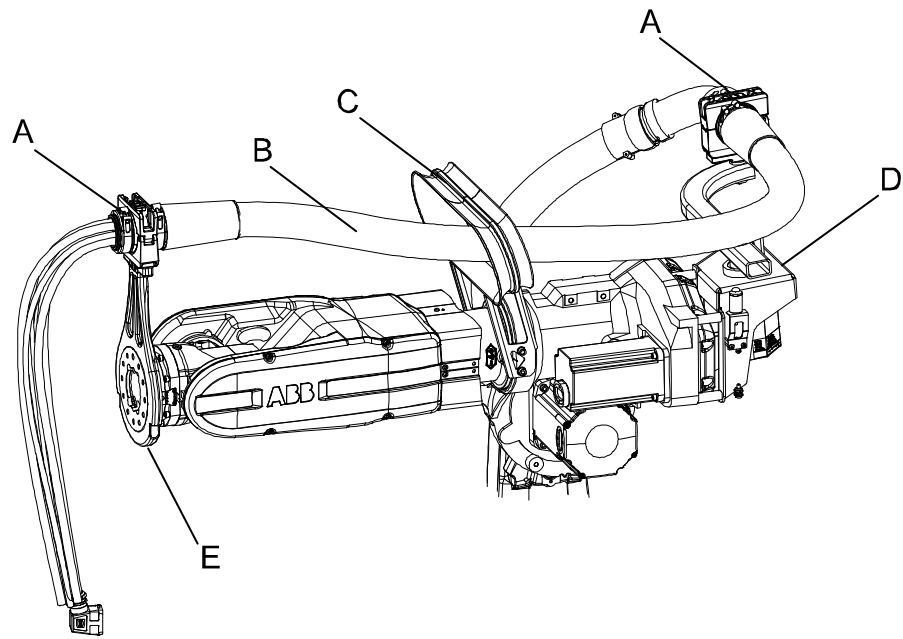

xx0600003167

| | |
|---|--|
| A | Slide sleeve slide surface |
| B | Process cable package |
| C | Hose support |
| D | Tension arm unit |
| E | Process cable support axis 6, complete |

3 Maintenance

3.4.1. Cleaning, DressPack upper arm

Continued

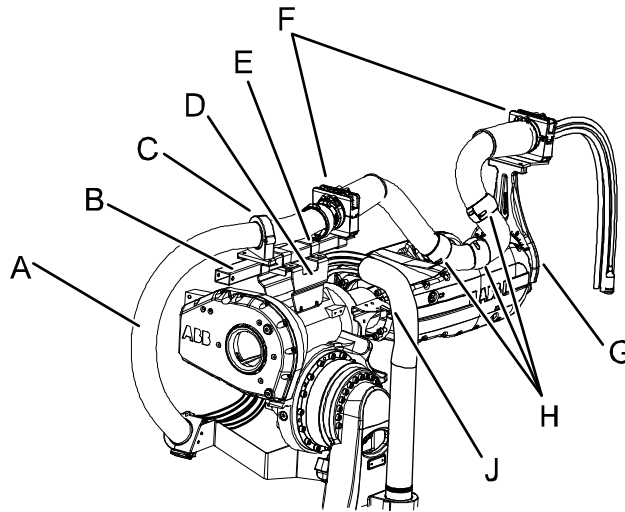

xx080000113

The figure shows cable package IRBDP SW 5 CE.

| | |
|---|--|
| A | Process cable package IRBDP SW 5 CE, upper end |
| B | Adjustable bracket |
| C | Gripping clamp |
| D | Axis 3 bracket |
| E | Bracket |
| F | Ball joint housing |
| G | Process cable support axis 6 |
| H | Slide sleeves |
| J | Spiral hose bracket |

Required equipment

| Equipment | Art. no. | Note |
|--------------------------------------|-------------|--|
| Standard Toolkit, DressPack/SpotPack | 3HAC17290-7 | The contents are defined in section Toolkits, DressPack/SpotPack on page 257 . |
| Dry rag and medium soft brush | | For cleaning the protective hose ribs. |

Cleaning

The procedure below details how to clean the DressPack upper arm.

| Action | Note |
|---|---|
| 1. Clean the DressPack upper arm exterior, in order to avoid filling up the spaces between the ribs with debris. Make sure to clean any areas where any hoses bend or rub against the robot. If the harness is not cleaned sufficiently, breakage of the protective hose may result. | Only use equipment and cleaning agents as specified in section Required equipment on page 146 . |
| 2. Clean the slide sleeves of any sort of contamination. | |

© Copyright 2006-2010 ABB. All rights reserved.

3.4.2. Cleaning, Water and air unit

Location of Water and air unit, type S

The Water and air unit is located as shown in the figure below.

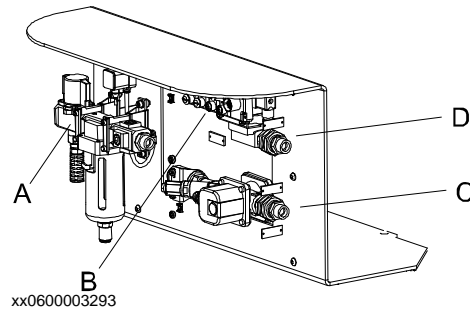

| | |
|---|----------------------|
| A | Air supply circuit |
| B | Split box |
| C | Water return circuit |
| D | Water in circuit |

Location Water and air unit, type Sb

The Water and air unit is located as shown in the figure below.

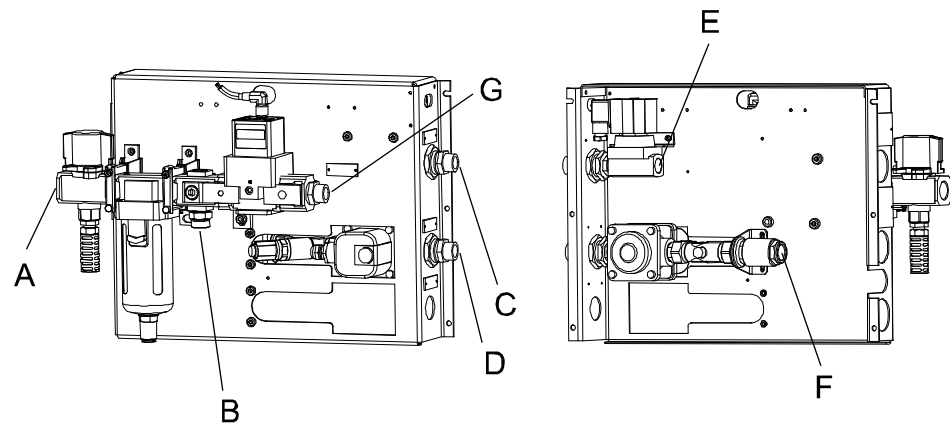

| | |
|---|-------------------------------|
| A | Shop compressed air supply |
| B | PROC 1 on robot base |
| C | PROC 2 on robot base |
| D | PROC 3 on robot base |
| E | Shop water supply |
| F | Shop water drain |
| G | PROC 4 on robot base (option) |

Required equipment

| Equipment | Note |
|-----------|---|
| Dry rag | When cleaning the Water and air unit, only use household neutral detergent! |

Continues on next page

3 Maintenance

3.4.2. Cleaning, Water and air unit

Continued

Maintenance of Air Filter

- Periodic inspection is necessary in order to check if there are any cracks in the resin bowl or other deterioration. If any are found, replace the bowl with a new one.
- Check the cleanliness of the resin bowl periodically. If the resin bowl is dirty, replace it with a new bowl or clean it. Use household (neutral) detergent only, when cleaning! Other detergent may cause breakage of the bowl.
- Replace the filter element within two years since first use.
- Replace the filter after pressure drop from initial outlet reaches 0.1 MPa.
- Replace if the filter element is broken.

Replacement of the air filter is detailed in section [Replacement of Air filter element on page 221](#).

3.4.3. Cleaning the Fan Unit

Overview

The section below details how to clean the fan unit.

Location

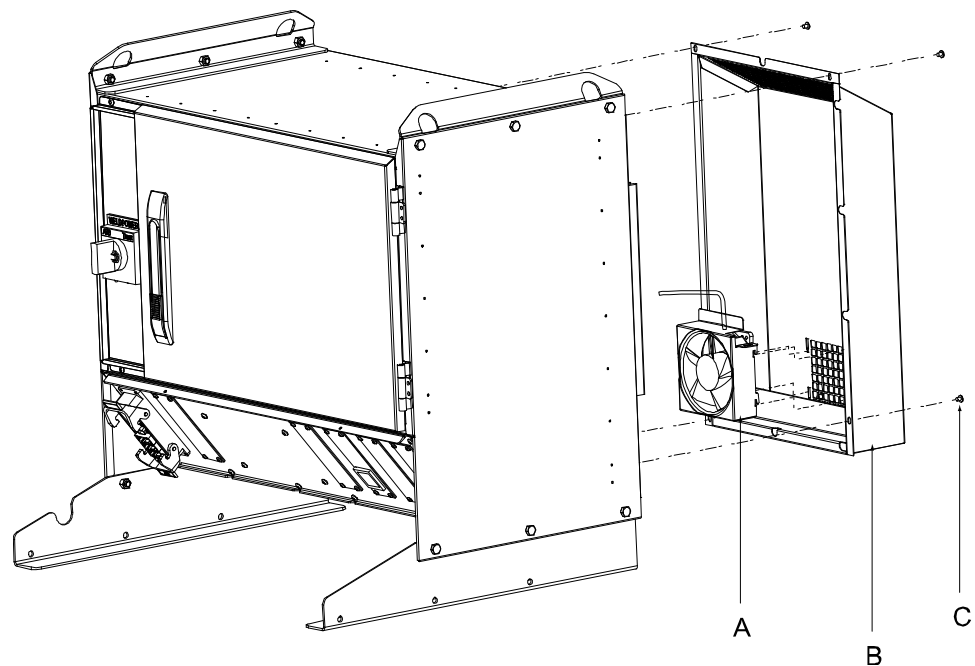

en0500001924

| | |
|---|---|
| A | Fan holder with fan |
| B | Fan casing |
| C | Attachment screws M5x9, Fastite screw (4 pcs) |

Required equipment

| Equipment | Art. no. | Note |
|-------------------------------------|-------------|--|
| Standard toolkit DressPack/SpotPack | 3HAC17290-7 | The contents are defined in section Toolkits, DressPack/SpotPack on page 257 . |
| Vacuum cleaner | - | |

Continues on next page

3 Maintenance

3.4.3. Cleaning the Fan Unit

Continued

Maintenance procedure

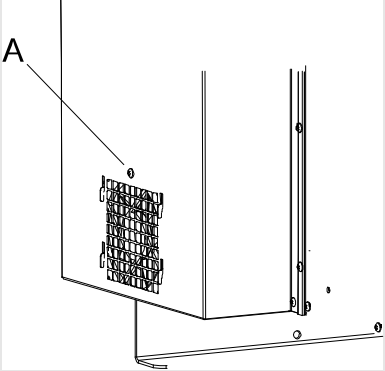
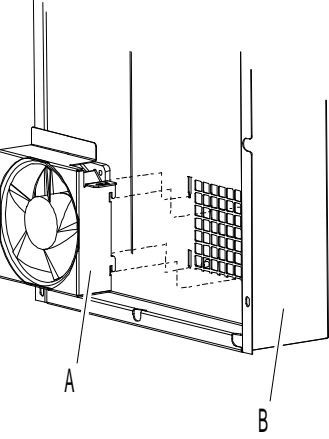
| | Action | Note |
|----|---|--|
| 1. |  DANGER! Before any work inside the cabinet, please observe the safety information in the section <i>DANGER - Make sure that the main power has been switched off</i> in the Product manual for the controller cabinet IRC5 | |
| 2. | Remove the <i>attachment screws</i> M5x9 Fastite (4 pcs) holding the fan casing. | Shown in the section Location on page 165 |
| 3. | Disconnect the fan connector. | |
| 4. | Remove the <i>stop screw</i> . |  xx0500002232 <ul style="list-style-type: none">• A: Stop screw |
| 5. | Lift out the <i>fan holder with fan</i> . |  xx0500002234 <ul style="list-style-type: none">• A: Fan holder with fan• B: Fan casing |
| 6. | Clean the fan. | |
| 7. | Refit according to the steps above, in reverse order. | |

© Copyright 2006-2010 ABB. All rights reserved.

3.4.4. Cleaning the Weld Timer cooling fins

Overview

The section below details the maintenance procedure on the weld timer.

Location

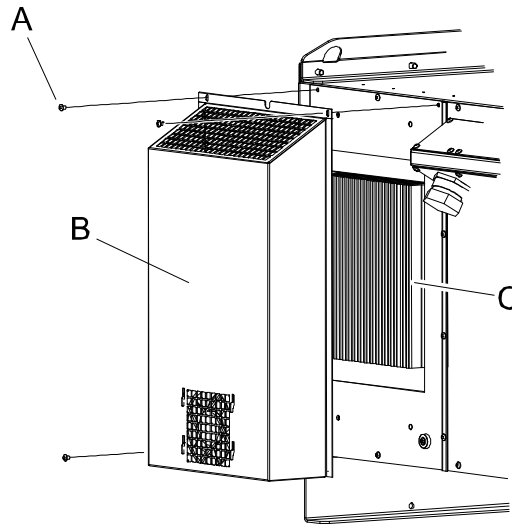

xx0500002240

| | |
|---|--|
| A | Attachment screws M5x9 Fastite screw (3 pcs) |
| B | Fan casing |
| C | Cooling fins |

Required equipment

| Equipment | Art.no. | Note |
|--------------------------------------|-------------|---|
| Standard toolkit DressPack/ SpotPack | 3HAC17290-7 | The contents are defined in section Toolkits, DressPack/SpotPack on page 257. |
| Vacuum cleaner. | | |

Maintenance procedure

| | Action | Note |
|----|--|------|
| 1. |  <p>DANGER! Before any work inside the cabinet, please observe the safety information in the section <i>DANGER - Make sure that the main power has been switched off</i> in the Product manual for the controller cabinet IRC5</p> | |

Continues on next page

3 Maintenance

3.4.4. Cleaning the Weld Timer cooling fins

Continued

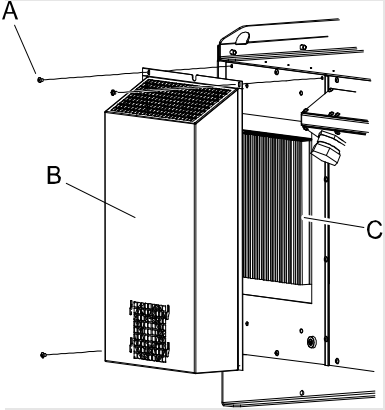
| Action | Note |
|--|--|
| 2. Remove the <i>attachment screws</i> M5x9 Fastite screw (3 pcs). |  <p>xx0500002240</p> <ul style="list-style-type: none">• A: Attachment screw (3 pcs)• B: Fan casing• C: Cooling fins |
| 3. Disconnect the fan connector. | |
| 4. Remove the <i>fan casing</i> . | See figure above! |
| 5. Clean the <i>cooling fins</i> with a vacuum cleaner. | See figure above! |
| 6. Refit the fan connector and fan casing. | |

4 Repair

4.1. Introduction

General

This chapter contains information on how to repair the equipment in question, that is how to replace the parts found in the *Spare parts* section.

Sections

The repair chapter is divided in the following sections:

- DressPack cable package
- Water and air unit
- Spotwelding cabinet
- Tipdresser.

4 Repair

4.2.1. Repair activities

4.2 DressPack cable package

4.2.1. Repair activities

General

The section below details the main activities of replacing the cable packages or parts thereof.

Procedures

| For information about: | See: |
|--|---|
| Replacement of the cable package IRBDP MH2 CE and IRBDP SW2 CE | Detailed in section Replacement of cable package IRBDP MH2 CE and IRBDP SW2 CE on page 171. |
| Replacement of <i>process cable package lower arm - IRBDP MH 3 LE.</i> | Detailed in section Replacement of the lower arm cable package - IRBDP MH 3 LE on page 177. |
| Replacement of <i>process cable package upper arm - IRBDP MH 3 UE.</i> | Detailed in section Replacement of upper arm cable package - IRBDP MH 3 UE on page 182. |
| Replacing the cable package IRBDP SW5 CE (SpotPack Basic). | Detailed in section Replacing the cable package IRBDP SW5 CE (SpotPack Basic) on page 185. |
| Replacement of <i>tension arm unit</i> | Detailed in section Replacement of tension arm unit on page 189 |
| Replacement of <i>hose reinforcement</i> | Detailed in section Replacement of hose reinforcement on page 205. |
| Replacement of <i>slide sleeves</i> | Detailed in section Replacement of slide sleeves on page 208. |
| Repair of <i>process cable package</i> | Detailed in section Repair of process cable package on page 195 |
| Adjusting <i>tension arm unit</i> | Detailed in section Adjusting tension arm unit on page 200 |

4.2.2. Replacement of cable package IRBDP MH2 CE and IRBDP SW2 CE

Location

This section details how to replace the cable package IRBDP MH2 CE and IRBDP SW2 CE. The actual work may differ due to the type of cables and hoses, the type of connectors etc. However, if differences are distinguishable, these are pointed out in the procedure description.

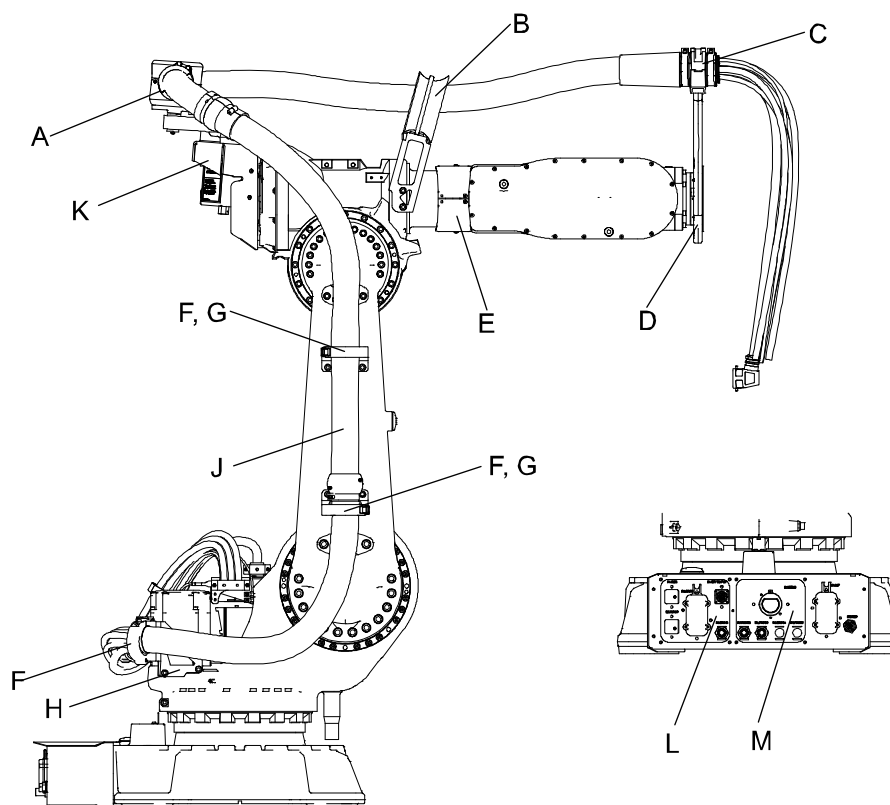

xx0600003151

| | |
|---|---|
| A | Ball joint housing (tension arm unit) |
| B | Hose support |
| C | Ball joint housing (process cable support axis 6) |
| D | Process cable support axis 6, complete |
| E | Arm protection |
| F | Gripping clamp |
| G | Bracket, lower arm |
| H | Bracket, back lower |
| J | Process cable package |
| K | Tension arm unit |
| L | Customer plate |
| M | Process plate |

Continues on next page

4 Repair

4.2.2. Replacement of cable package IRBDP MH2 CE and IRBDP SW2 CE

Continued

Required equipment

The following equipment are required for replacement of the lower/upper arm cable package.

| Equipment | Art. no. | Note |
|--|----------------------------------|---|
| Cable package IRBDP MH2 CE | | A number of versions are available. See <i>Spare Parts chapter</i> . |
| Cable package IRBDP SW2 CE | | A number of versions are available. See <i>Spare parts chapter</i> . |
| Locking liquid | 3HAB7116-1 | Loctite 243. For locking the metal clamps. |
| Standard toolkit, DressPack/ SpotPack | 3HAC17290-7 | The contents are described in section <i>Toolkit, SpotPack/ DressPack</i> . |
| Other tools and procedures may be required. See references to these procedures in the step-by-step instructions below. | | These procedures include references to the tools required. |
| Circuit diagram | 3HAC026136-001 3HAC026208-001 | |

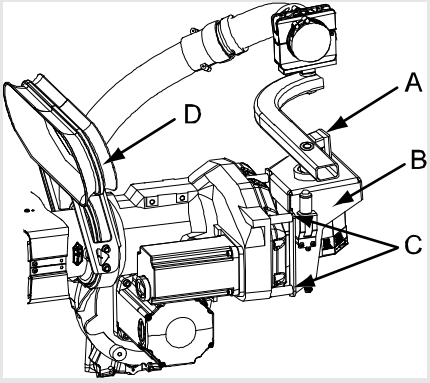

Procedure

The procedure below details how to remove the cable package IRBDP MH2 CE and IRBDP SW2 CE from the robot, before it is disassembled.

| Action | Note |
|---|--|
| <p>1. </p> <p>WARNING!</p> <p>In order to avoid accidents place the robot in a service position (upper arm slightly upwards) with the <i>tension arm</i> resting against the <i>damper</i>.</p> |  <p>xx0600003179</p> <p>Parts:</p> <ul style="list-style-type: none"> • A: Damper • B: Tension arm unit • C: Attachment screws (4 pcs) • D: Hose support |

© Copyright 2006-2010 ABB. All rights reserved.

Continues on next page

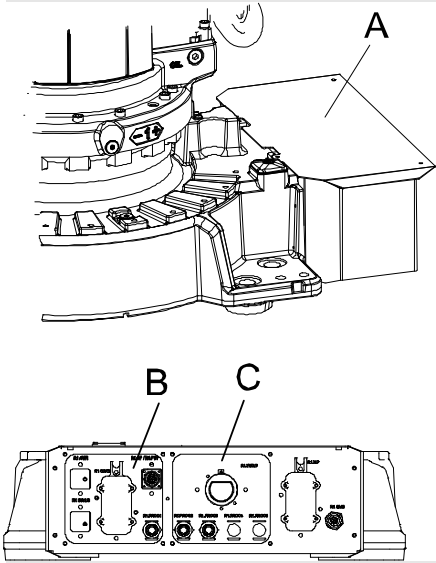
| | Action | Note |
|----|--|---|
| 2. |  <p>DANGER! Turn off all electric power, hydraulic and pneumatic pressure supplies to the robot! For Foundry Prime robots: Do not turn off the air pressure to motors and SMB.</p> | |
| 3. |  <p>CAUTION! The cable package is sensitive to mechanical damage. They must be handled with care, especially the connectors, in order to avoid damaging them.</p> | |
| 4. | Disconnect all hoses at tool side. | |
| 5. | Remove the <i>cover plate</i> in the back of the robot base. |  <p>xx0600003174</p> <p>Parts:</p> <ul style="list-style-type: none"> • A: Cover plate • B: Customer plate • C: Process plate |

4 Repair

4.2.2. Replacement of cable package IRBDP MH2 CE and IRBDP SW2 CE

Continued

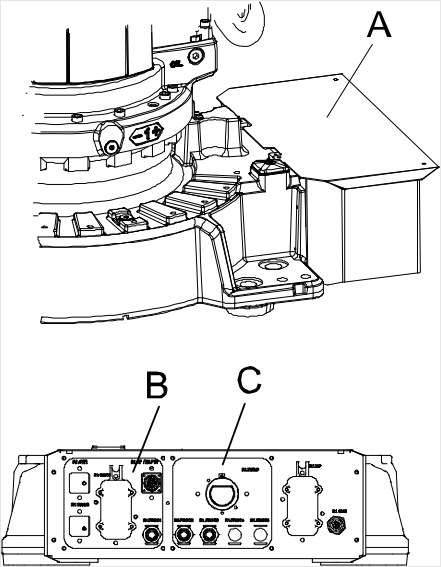
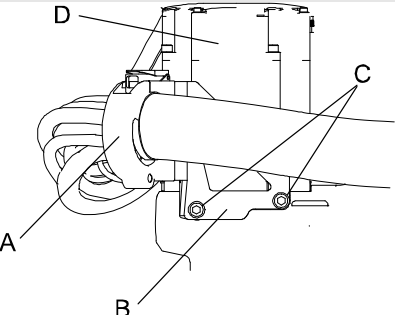
| Action | Note |
|--|--|
| 6. Disconnect all hoses and connectors from the <i>customer</i> and <i>process plates</i> . |  <p>xx0600003174</p> <p>Parts:</p> <ul style="list-style-type: none">• A: Cover plate• B: Customer plate• C: Process plate |
| 7. Open the gripping clamp on the base frame, and remove the cable package. |  <p>xx0600003169</p> <p>Parts:</p> <ul style="list-style-type: none">• A: Gripping clamp• B: Bracket, back lower• C: Attachment screws, bracket M10x16 quality 8.8• D: Motor axis 1 |
| 8. Loosen the weld cable clamp and pull the <i>weld cable</i> up through the centrum hole of gearbox axis 1. | |

© Copyright 2006-2010 ABB. All rights reserved.

Continues on next page

Continued

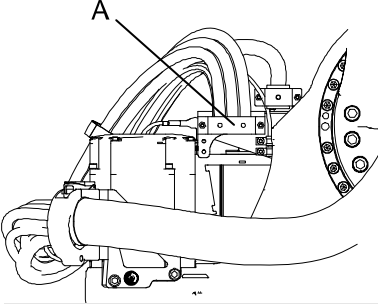
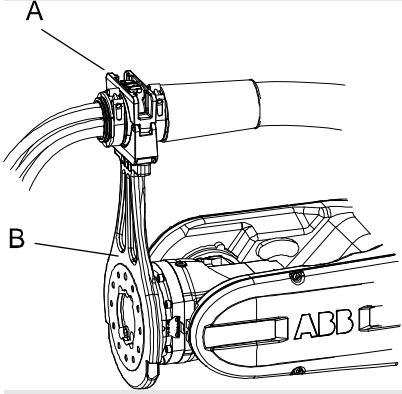
| | Action | Note |
|--|--|--|
| | 9. Loosen the complete <i>cable and hose clamp</i> . |  <p>xx0600003188</p> <p>Parts:</p> <ul style="list-style-type: none"> A: Cable clamp (Attachment screws M10x16, 3 pcs are not visible in this figure) |
| | 10. Pull the <i>hoses</i> up through the centrum hole of gearbox axis 1. | |
| | 11. Pull the <i>cables</i> up through the centrum hole gear box axis 1. | |
| | 12. Disconnect all cables at tool side. | |
| | 13. Open the <i>ball joint housing</i> on the <i>process cable support, axis 6</i> and remove the cable package. |  <p>xx0600003173</p> <p>Parts:</p> <ul style="list-style-type: none"> A: Ball joint housing B: Process cable support axis 6, complete |

4 Repair

4.2.2. Replacement of cable package IRBDP MH2 CE and IRBDP SW2 CE

Continued

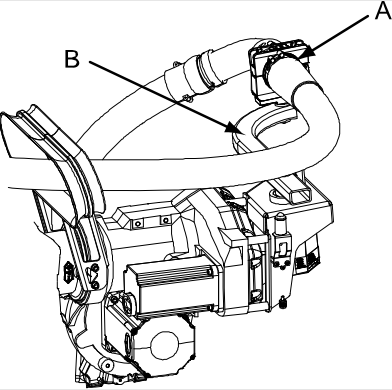
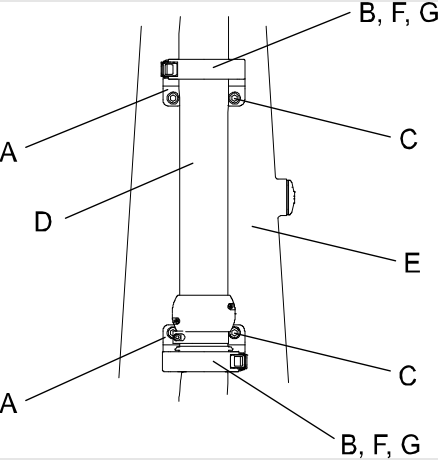
| | Action | Note |
|-----|---|--|
| 14. | Open the <i>ball joint housing</i> on the <i>tension arm unit</i> , and remove the cable package. |  <p>xx0600003180</p> <p>Parts:</p> <ul style="list-style-type: none"> • A: Ball joint housing • B: Tension arm unit |
| 15. | Open the upper and lower <i>gripping clamps</i> on the lower arm and remove the cable package. |  <p>xx0600003170</p> <p>Parts:</p> <ul style="list-style-type: none"> • A: Bracket lower arm • B: Gripping clamp • C: Attachment screws, bracket M10x16 quality 8.8 (2 pcs) • D: Process cable package • E: Lower arm • F: Attachment screws, gripping clamp M8x16 quality 8.8 (2 + 2 pcs) • G: Washer 2 holes |
| 16. | Fit the new or repaired cable package. | Detailed in section, Fitting the cable package IRBDP SW2 CE IRBDP MH2 CE and on page 67 |

© Copyright 2006-2010 ABB. All rights reserved.

4.2.3. Replacement of the lower arm cable package - IRBDP MH 3 LE

Location

This section details how to replace the cable package IRBDP MH 3 LE. The actual work may differ due to the type of cables and hoses, the type of connectors etc. However, if differences are distinguishable, these are pointed out in the procedure description.

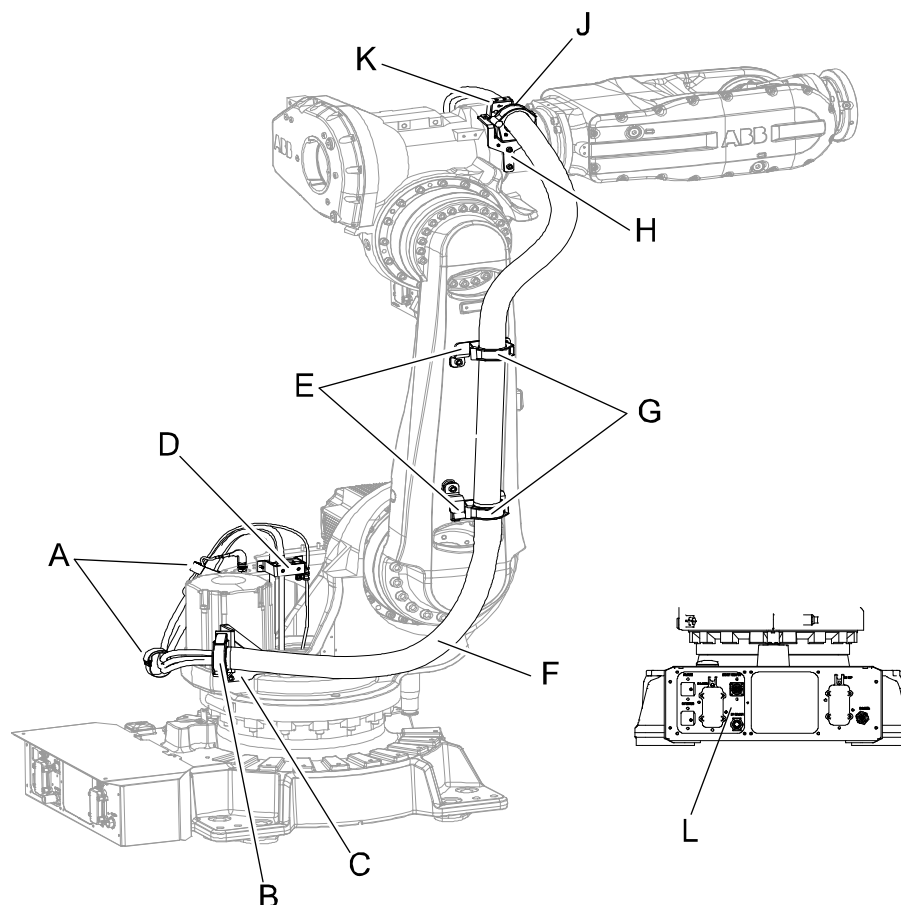

xx070000596

| | |
|---|---------------------------------|
| A | Strap velcro |
| B | Gripping clamp (on frame) |
| C | Bracket back lower |
| D | Metal clamp with rubber clamp |
| E | Bracket, lower arm |
| F | Protection hose (Cable package) |
| G | Gripping clamp (on lower arm) |
| H | Bracket for clamp |
| J | Gripping clamp (on upper arm) |
| K | Metal clamp with rubber clamp |
| L | Customer plate |

4 Repair

4.2.3. Replacement of the lower arm cable package - IRBDP MH 3 LE

Continued



Required equipment

The following equipment is required for replacement of the cable package IRBDP MH 3 LE.

| Equipment | Art. no. | Note |
|---|----------------------------------|--|
| Cable package IRBDP MH 3 LE | | |
| Locking liquid | 3HAB 7116-1 | Loctite 243 For locking screws. |
| Standard toolkit, DressPack/ SpotPack | 3HAC17290-7 | The contents are defined in section Toolkits, DressPack/ SpotPack on page 257 . |
| Other tools and procedures may be required. See references to these procedures in the step-by-step instructions below. | | These procedures include references to the tools required. |
| Circuit diagram | 3HAC026136-001 3HAC026208-001 | |

Procedures

The procedure below details how to remove the cable package IRBDP MH 3 LE from the robot, before it is disassembled.

| | Action | Note |
|----|---|------|
| 1. |  DANGER! Turn off all electric power, hydraulic and pneumatic pressure supplies to the robot! For Foundry Prime robots: Do not turn off the air pressure to motors and SMB. | |
| 2. |  CAUTION! The cable package is sensitive to mechanical damage. They must be handled with care, especially the connectors, in order to avoid damaging them. | |

© Copyright 2006-2010 ABB. All rights reserved.

Continues on next page

Continued

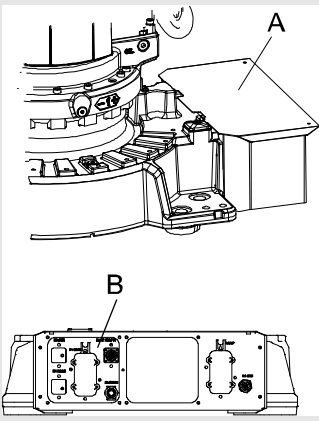
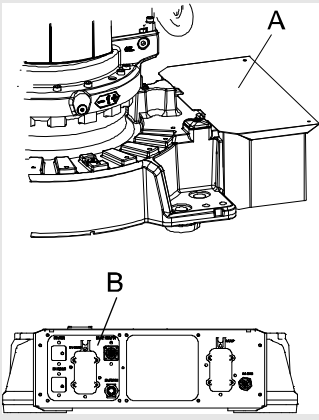
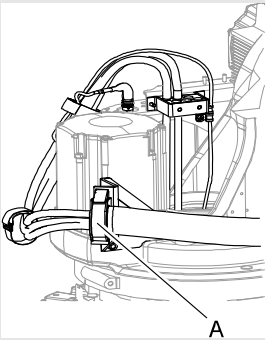
| | Action | Note |
|--|---|---|
| | 3. Remove the <i>cover plate</i> in the back of the robot base. |  <p>xx0700000618</p> <p>Parts:</p> <ul style="list-style-type: none"> • A: Cover plate • B: Customer plate |
| | 4. Disconnect all hoses and connectors from the <i>customer</i> and <i>process plates</i> . |  <p>xx0700000618</p> <p>Parts:</p> <ul style="list-style-type: none"> • A: Cover plate • B: Customer plate |
| | 5. Open the <i>gripping clamp</i> on the base frame and remove the cable package. |  <p>xx0600003169</p> <p>Parts:</p> <ul style="list-style-type: none"> • Gripping clamp |

Continues on next page

4 Repair

4.2.3. Replacement of the lower arm cable package - IRBDP MH 3 LE

Continued

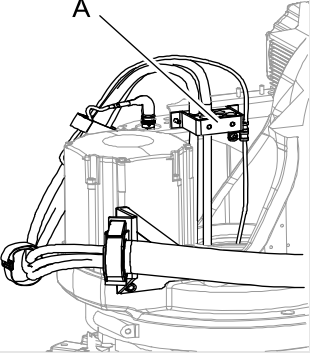
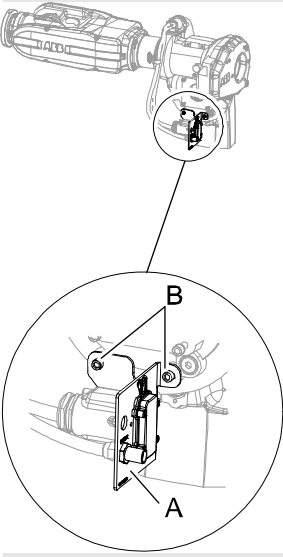
| Action | Note |
|---|---|
| 6. Remove the complete <i>cable holder bracket</i> , with metal clamp, from the base. |  <p>xx0700000598</p> <p>Parts:</p> <ul style="list-style-type: none">• A: Cable holder bracket |
| 7. Pull hose and cables up through the centrum hole gearbox axis 1, in the following order: 1. Hose 2. Cables | |
| 8. Disconnect all cable and hose connectors from the <i>connection plate</i> . |  <p>xx0700000588</p> <p>Parts:</p> <ul style="list-style-type: none">• A: Connection plate• B: Attachment screws |

© Copyright 2006-2010 ABB. All rights reserved.

Continues on next page

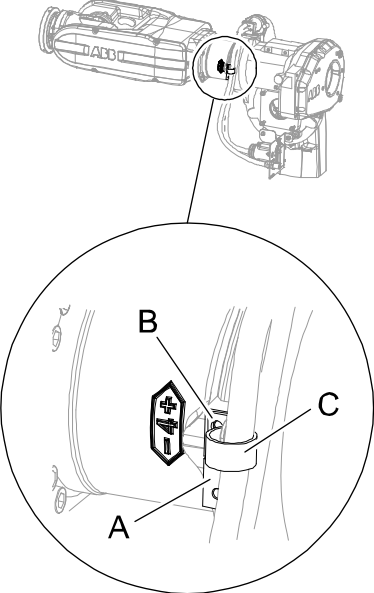
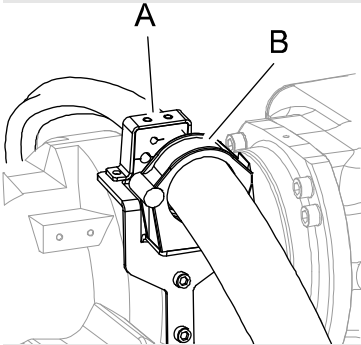
| | Action | Note |
|--|---|--|
| | 9. Loosen the velcro strap around cables and hose at the cable fixing bracket. |  <p data-bbox="991 947 1102 965">xx070000585</p> <p data-bbox="991 974 1059 999">Parts:</p> <ul data-bbox="1034 1010 1316 1106" style="list-style-type: none"> • A: Cable fixing bracket • B: Attachment screws • C: Velcro strap |
| | 10. Remove the <i>metal clamp with rubber clamp</i> on the upper arm. |  <p data-bbox="991 1485 1102 1503">xx070000614</p> <p data-bbox="991 1512 1059 1536">Parts:</p> <ul data-bbox="1034 1547 1430 1608" style="list-style-type: none"> • A: Metal clamp with rubber clamp • B: Gripping clamp |
| | 11. Open the <i>gripping clamp</i> . | See figure above! |
| | 12. Open the upper and lower gripping clamps on the lower arm and remove the cable package. | Shown in the figure in section Location on page 177 . |
| | 13. Fit the new or repaired cable package. | Detailed in section Fitting the lower arm cable package - IRBDP MH 3 LE on page 74 . |

4 Repair

4.2.4. Replacement of upper arm cable package - IRBDP MH 3 UE

4.2.4. Replacement of upper arm cable package - IRBDP MH 3 UE

Location

The location of the cable package IRBDP MH 3 UE is shown in the figure below.

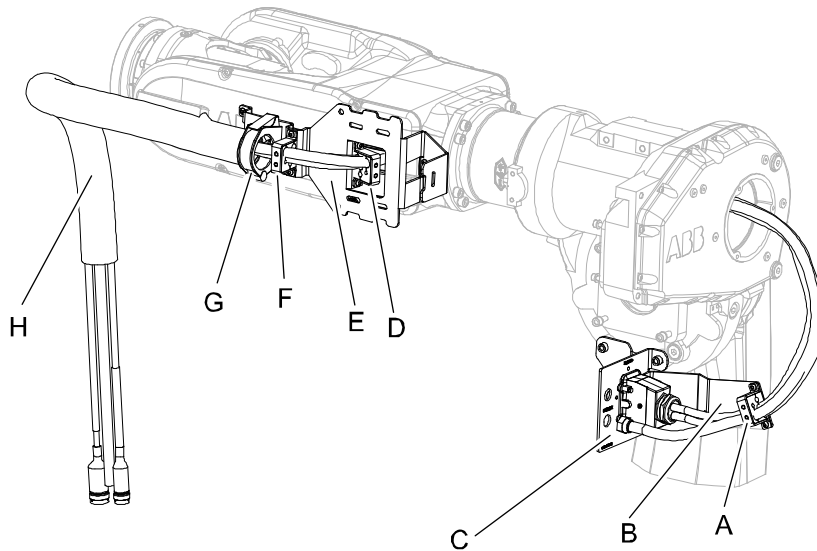

xx0700000580

| | |
|---|---------------------------------------|
| A | Metal clamp with rubber clamp |
| B | Bracket for metal clamp |
| C | Connection plate ax 3 |
| D | Metal clamp with rubber clamp (right) |
| E | Bracket at wrist |
| F | Metal clamp with rubber clamp (left) |
| G | Gripping clamp & clamp halves |
| H | Protection hose |

Required equipment

The following equipment is required for replacement of the cable package IRBDP MH 3 UE.



| Equipment | Art. no. | Note |
|--|----------------|--|
| Cable package IRBDP MH 3 UE | | |
| Standard toolkit, DressPack/ SpotPack | 3HAC17290-7 | The contents are defined in section Toolkits, DressPack/SpotPack on page 257 . |
| Other tools and procedures may be required. See references to these procedures in the step-by-step instructions below. | | These procedures include references to the tools required. |
| Circuit diagram | 3HAC026209-001 | |

© Copyright 2006-2010 ABB. All rights reserved.

Continues on next page

Procedure

The procedure below details how to remove the cable package IRBDP MH 3 UE from the robot, before it is disassembled.

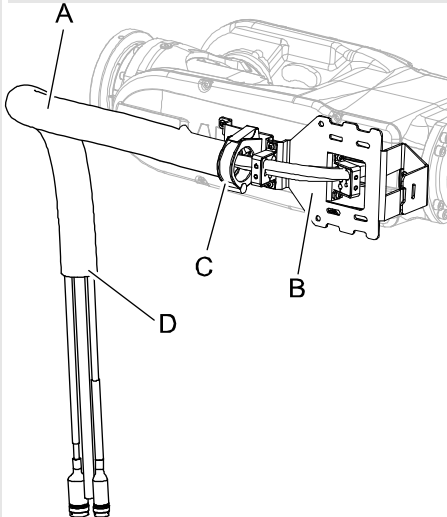
| | Action | Note |
|----|--|---|
| 1. |  <p>DANGER! Turn off all electric power, hydraulic and pneumatic pressure supplies to the robot! For Foundry Prime robots: Do not turn off the air pressure to motors and SMB.</p> | |
| 2. |  <p>CAUTION! The cable package is sensitive to mechanical damage. They must be handled with care, especially the connectors, in order to avoid damaging them.</p> | |
| 3. | Open the gripping clamp at the front end of the cable package. | |
| 4. | If the cables has been put in a loop and fitted with straps on the bracket at wrist, remove the straps. | |
| 5. | Open the gripping clamp on the bracket at wrist. |  <p>xx070000609</p> <p>Parts:</p> <ul style="list-style-type: none"> • A: Protection hose • B: Bracket at wrist • C: Gripping clamp • D: Place for gripping clamp (front) |

4 Repair

4.2.4. Replacement of upper arm cable package - IRBDP MH 3 UE

Continued

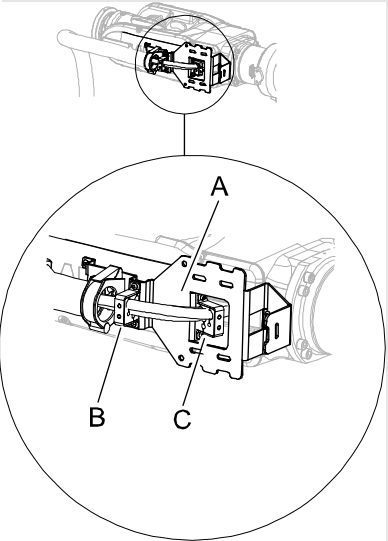
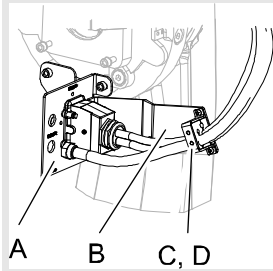
| | Action | Note |
|-----|---|--|
| 6. | Remove the <i>metal clamp with rubber clamp</i> - left and right - on <i>bracket at wrist</i> . |  <p>xx0700000606</p> <p>Parts:</p> <ul style="list-style-type: none"> • A: Bracket at wrist • B: Metal clamp with rubber clamp (left) • C: Metal clamp with rubber clamp (right) |
| 7. | Remove the <i>metal clamp with rubber clamp</i> on the <i>bracket for metal clamp</i> . |  <p>xx0700000605</p> <p>Parts:</p> <ul style="list-style-type: none"> • A: Connection plate • B: Bracket for metal clamp • C: Metal clamp with rubber clamp • D: Attachment screws |
| 8. | Disconnect all cable and hose connectors from the <i>connection plate</i> . | Shown in the figure above! |
| 9. | Pull out the cable package from the upper arm and put it in a safe place. | |
| 10. | Refit the new or repaired cable package. | Detailed in section Fitting the upper arm cable package - IRBDP MH 3 UE on page 81 . |

© Copyright 2006-2010 ABB. All rights reserved.

4.2.5. Replacing the cable package IRBDP SW5 CE (SpotPack Basic)

Overview

This procedure describes how to replace the cable package IRBDP SW5 CE (SpotPack Basic).

Location of the cable package IRBDP SW5 CE

The cable package IRBDP SW5 CE (SpotPack Basic) consists of the parts shown in the figure.

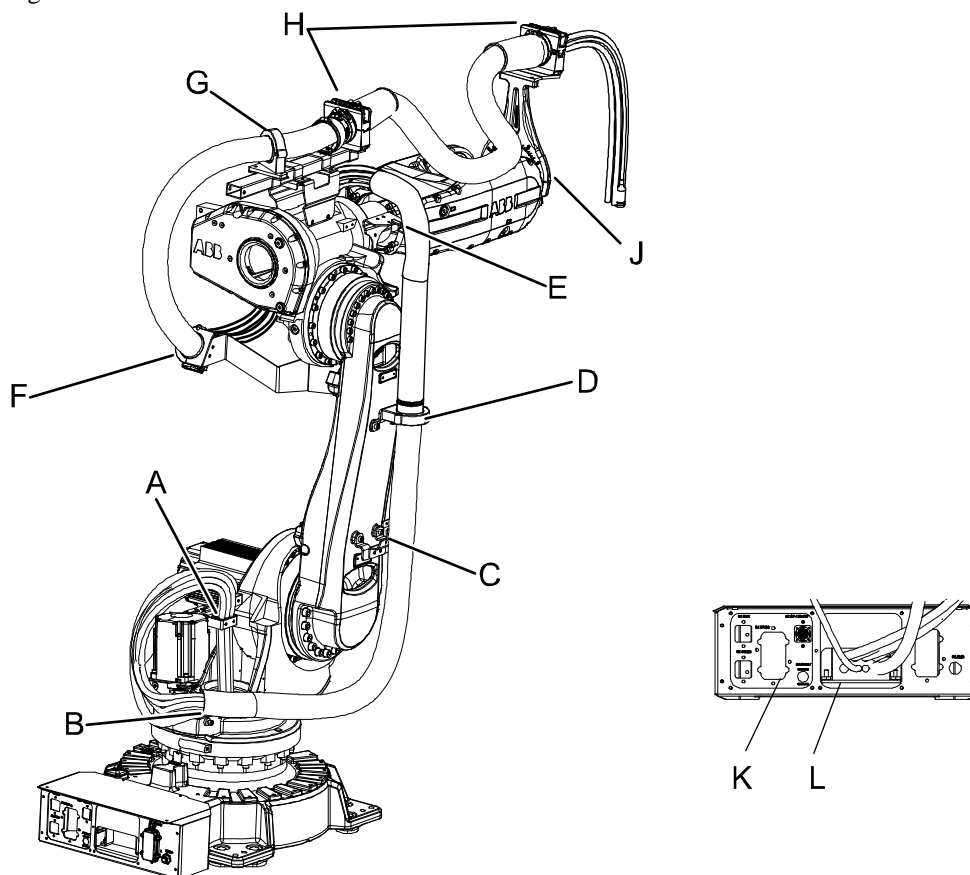

xx0800000111

| | |
|---|---|
| A | Cable and hose clamp |
| B | Spiral hose clamp (bracket back lower) |
| C | Spiral hose clamp (lower bracket) |
| D | Gripping clamp (lower bracket) |
| E | Spiral hose clamp (spiral hose bracket) |
| F | Gripping clamp (axis 3 clamp mount) |
| G | Gripping clamp (adjustable bracket) |
| H | Ball joint housing |
| J | Process cable support axis 6 |
| K | Customer plate |
| L | Clamp holder with plastic clamp |

Continues on next page

4 Repair

4.2.5. Replacing the cable package IRBDP SW5 CE (SpotPack Basic)



Continued

Required equipment

| Equipment | Art. no. | Note |
|--|------------------|--|
| Cable package IRBDP SW5 CE | See Spare parts. | |
| Standard toolkit, DressPack/SpotPack | 3HAC17290-7 | The contents are defined in section Toolkits, DressPack/SpotPack on page 257 . |
| Other tools and procedures may be required. See references to these procedures in the step-by-step instructions below. | | These procedures include references to the tools required. |

Removal

Use this procedure to remove the cable package IRBDP SW5 CE from the robot before it is disassembled.

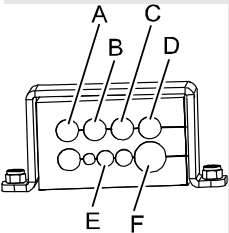
| Action | Note |
|--|---|
| <p>1. </p> <p>DANGER!</p> <p>Turn off all electric power, hydraulic and pneumatic pressure supplies to the robot!</p> <p>For Foundry Prime robots: Do not turn off the air pressure to motors and SMB.</p> | |
| <p>2. </p> <p>CAUTION!</p> <p>The cable package is sensitive to mechanical damage. They must be handled with care, especially the connectors, in order to avoid damaging them.</p> | |
| <p>3. Remove the <i>clamp holder with plastic clamp</i> in the back of the robot base, securing the cable package.</p> |  <p>xx080000079</p> <p>Parts:</p> <ul style="list-style-type: none"> • Clamp holder with plastic clamp |

© Copyright 2006-2010 ABB. All rights reserved.

Continues on next page

4.2.5. Replacing the cable package IRBDP SW5 CE (SpotPack Basic)

Continued

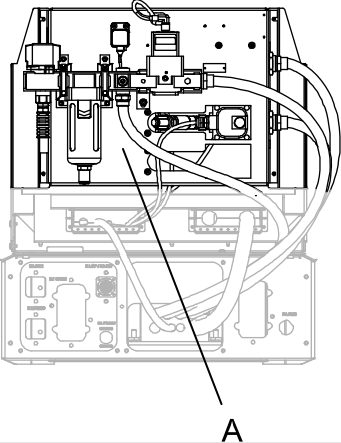
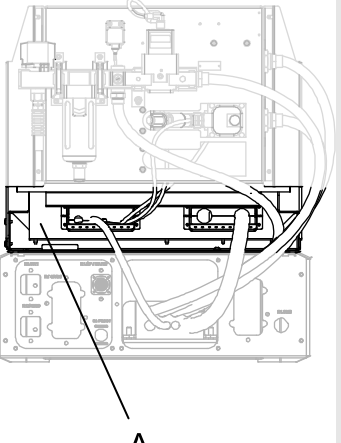
| | Action | Note |
|--|---|---|
| | 4. Disconnect all cables and hoses at the <i>water and air unit</i> . |  <p>xx080000083</p> <p>Parts:</p> <ul style="list-style-type: none"> • A: Water and air unit |
| | 5. Disconnect all cables and hoses at the <i>connection box</i> . |  <p>xx080000082</p> <p>Parts:</p> <ul style="list-style-type: none"> • A: Connection box |
| | 6. Pull the lower end of the cable package carefully up through the center hole in gearbox axis 1. Order of disassembly: 1. Hoses 2. Signal cables | |
| | 7. Loosen the <i>spiral hose clamp</i> on the bracket back lower. | Shown in the figure Location of the cable package IRBDP SW5 CE on page 185 . |
| | 8. Loosen the <i>spiral hose clamp</i> on the lower bracket. | Shown in the figure Location of the cable package IRBDP SW5 CE on page 185 . |
| | 9. Open the <i>gripping clamp</i> on the lower bracket. | Shown in the figure Location of the cable package IRBDP SW5 CE on page 185 . |
| | 10. Open the <i>gripping clamp</i> on the axis 3 cable bracket. | Shown in the figure Location of the cable package IRBDP SW5 CE on page 185 . |
| | 11. Open the <i>gripping clamp</i> on the adjustable bracket. | Shown in the figure Location of the cable package IRBDP SW5 CE on page 185 . |

Continues on next page

4 Repair

4.2.5. Replacing the cable package IRBDP SW5 CE (SpotPack Basic)

Continued

| | Action | Note |
|-----|---|---|
| 12. | Open the <i>ball joint housings</i> at the process cable support axis 6 and adjustable bracket. | Shown in the figure <i>Location of the cable package IRBDP SW5 CE on page 185</i> . |
| 13. | Remove the complete process cable package. | |

Refitting

Use this procedure to remove the cable package IRBDP SW5 CE.

| | Action | Note |
|----|---|------|
| 1. | Refitting of the process cable package IRBDP SW 5 CE is detailed in section <i>Fitting the cable package IRBDP SW5 CE (SpotPack Basic) on page 86</i> . | |

4.2.6. Replacement of tension arm unit

**NOTE!**

This section is not applicable to cable package IRBDP MH 3 UE.

Location of tension arm unit

The tension arm is located as shown in the illustration below.

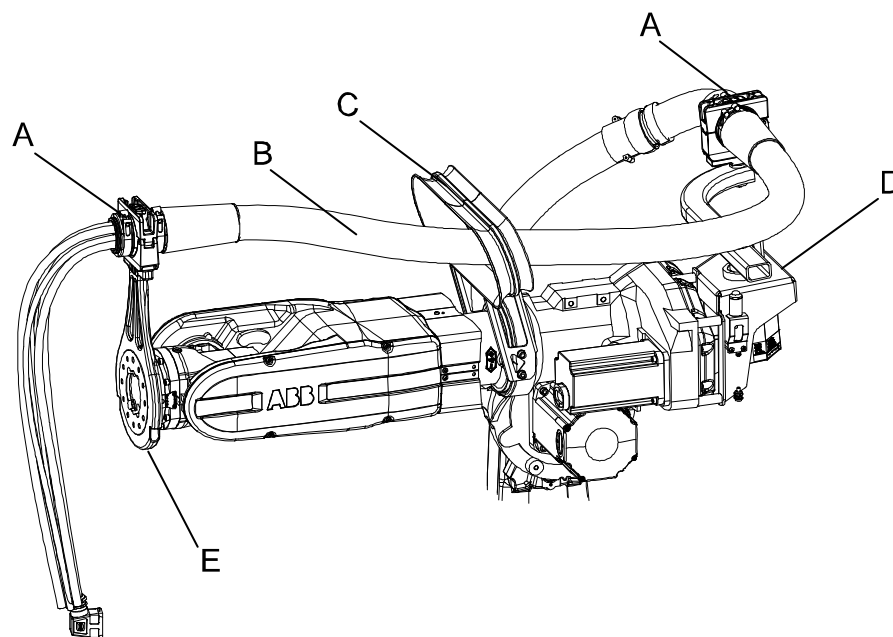

xx0600003167

| | |
|---|-------------------------------|
| A | Slide sleeves slide surface |
| B | Process cable package |
| C | Hose support |
| D | Tension arm unit |
| E | Process cable support, axis 6 |

Required equipment

| Equipment | Spare part no. | Art. no. | Note |
|--------------------------------------|----------------|-------------|--|
| Standard Toolkit, DressPack/SpotPack | | 3HAC17290-7 | The contents are defined in section <i>Toolkits, DressPack/SpotPack</i> on page 257. |
| Tension arm unit | 3HAC025105-001 | | |
| Locking liquid | | 3HAB7116-1 | Loctite 243 |

Continues on next page





4 Repair

4.2.6. Replacement of tension arm unit

Continued

Procedure

The procedure below details how to replace the tension arm unit.

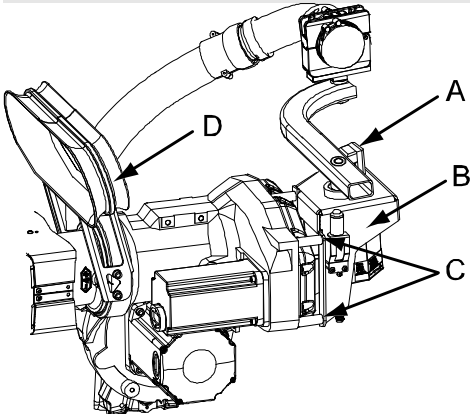
| | Action | Note |
|----|---|---|
| 1. |  DANGER! Turn off all electric power, hydraulic and pneumatic pressure supplies to the robot! For Foundry Prime robots: Do not turn off the air pressure to motors and SMB. | |
| 2. |  CAUTION! The cable package is sensitive to mechanical damage. They must be handled with care, especially the connectors, in order to avoid damaging them. | |
| 3. |  WARNING! The spring inside the tension unit is under tension! Never disassemble the unit! Always exercise care when working with the tension arm unit! | |
| 4. |  WARNING! In order to avoid accidents place the robot arm in a service position (upper arm slightly upwards) with the <i>tension arm</i> resting against the <i>damper</i> . |  xx0600003179 Parts: <ul style="list-style-type: none">• A: Damper• B: Tension arm unit• C: Attachment screws• D: Hose support |

© Copyright 2006-2010 ABB. All rights reserved.

Continues on next page

Continued

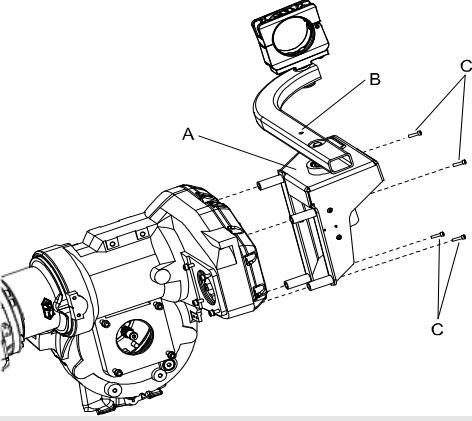
| | Action | Note |
|--|---|--|
| | 5. Remove the cable package from the ball joint housing on the tension arm unit. | Detailed in section Replacement of cable package IRBDP MH2 CEandIRBDP SW2 CE on page 171. |
| | 6. Loosen the <i>attachment screws</i> M12x25 quality 8.8-A3F (4 pcs) holding the <i>tension arm unit</i> . It is possible to use the Ø10 mm hole with suitable lifting equipment, to lift the tension arm unit. |  <p>xx0600003185</p> <p>Parts:</p> <ul style="list-style-type: none"> • A: Tension arm unit • B: Ø10 mm hole • C: Attachment screws M12x80 (4 pcs) Gleitmo 12.9. Tightening torque: 70 Nm |
| | 7. Replace the <i>tension arm unit</i> , and tighten the four <i>attachment screws</i> . Lock screws with locking liquid. | Art. no. is specified in Required equipment on page 189. |
| | 8. Refit the cable package. | Detailed in section Fitting the cable package IRBDP SW2 CE IRBDP MH2 CEand on page 67. |

4 Repair

4.2.7. Replacement of protective sleeves

4.2.7. Replacement of protective sleeves



NOTE!

This section is not applicable to cable package IRBDP MH 3 UE.



NOTE!

Protective sleeves are **not** fitted at delivery!

Location of protective sleeve

The protective sleeves can be located in the area shown in the figure below, (if needed).

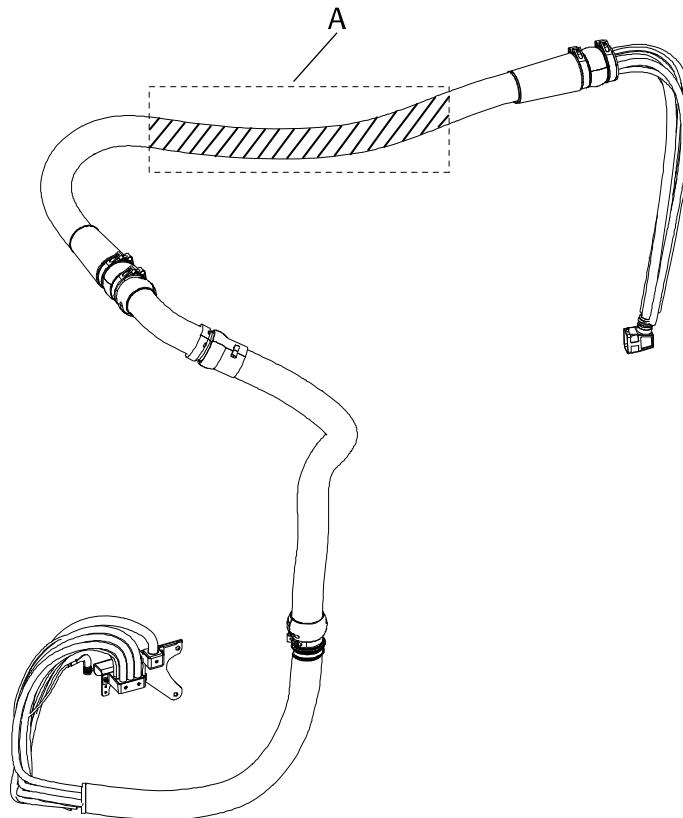

xx0600003190

A Area where slide sleeves may be fitted.

Required equipment

The following equipment are required for replacement of protective sleeves.



| Equipment | Art. no. | Note |
|--------------------------------------|----------------|--|
| Protective sleeve | 3HAC021580-001 | See Spare parts <i>DressPack for - IRBDP MH 2 CE and IRBDP SW 2 CE on page 262.</i> |
| Standard toolkit, DressPack/SpotPack | 3HAC17290-7 | The contents are defined in section <i>Toolkits, DressPack/SpotPack on page 257.</i> |

Continued

| Equipment | Art. no. | Note |
|--|----------|--|
| Other tools and procedures may be required. See references to these procedures in the step-by-step instructions below. | | These procedures include references to the tools required. |

Procedures

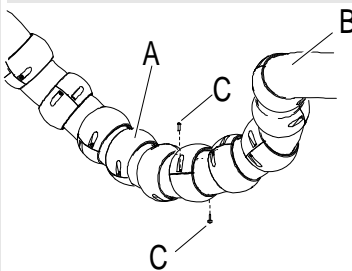

The procedure below details how to change or move the protective sleeves.

| | Action | Note |
|----|--|--|
| 1. |  <p>DANGER! Turn off all electric power, hydraulic and pneumatic pressure supplies to the robot! For Foundry Prime robots: Do not turn off the air pressure to motors and SMB.</p> | |
| 2. |  <p>CAUTION! The cable package is sensitive to mechanical damage. They must be handled with care, especially the connectors, in order to avoid damaging them.</p> | |
| 3. | Remove the two <i>attachment screws</i> . |  <p>xx0500001551</p> <p>Parts:</p> <ul style="list-style-type: none"> • A: Protective sleeve • B: Protective hose • C: Attachment screw (2 pcs) |

4 Repair

4.2.7. Replacement of protective sleeves

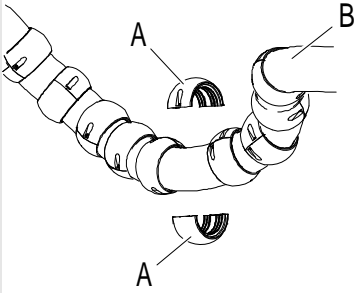
Continued

| | Action | Note |
|----|---|--|
| 4. | Split the <i>protective sleeve</i> . |  <p>xx0500001550</p> <p>Parts:</p> <ul style="list-style-type: none">• A: Protective sleeve• B: Protective hose |
| 5. | Replace or move the protective sleeve. | |
| 6. |  NOTE! When moving or adding protective sleeves, always leave a space between them (approximately the width of one slide sleeve). | |
| 7. | Attach the two <i>attachment screws</i> . | |

4.2.8. Repair of process cable package



NOTE!

This section is not applicable to cable package IRBDP MH 3 UE.

General

This section details how to disassemble the DressPack cable package. The actual work may differ due to the type of cables and hoses, the type of connectors etc. However, if differences are distinguishable, these are pointed out in the procedure description.

All work detailed in the procedure below is to be performed on a workbench. How to remove the DressPack from the robot is detailed in one or more of the sections listed below depending on which cable package is used:

- *Replacement of lower/upper arm cable package*
- *Repair of process cable package on page 195*

Upper arm cable package parts

The upper arm cable package consists of the parts described in the figure below.

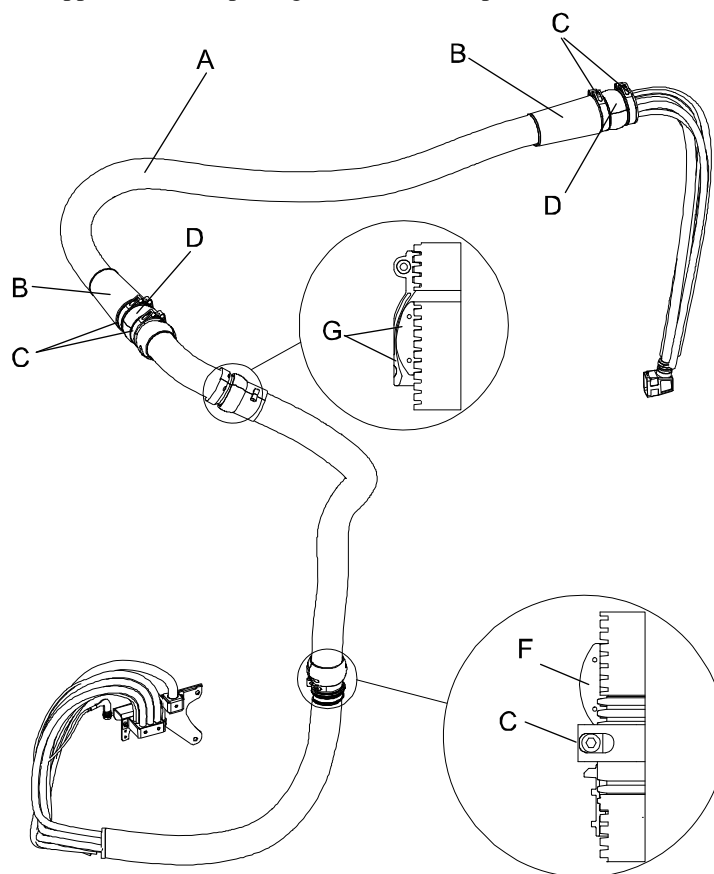

xx0600003168

| | |
|---|-------------------------------------|
| A | Reinforced protection hose, 1880 mm |
| B | Hose reinforcement |
| C | Hose clamp |
| D | Slide sleeve |

Continues on next page

4 Repair

4.2.8. Repair of process cable package

Continued

| | |
|---|-------------------|
| F | Protective sleeve |
| G | Swivel |

Required equipment

| Equipment, etc. | Art. no. | Note |
|--|----------------------------------|--|
| Standard Toolkit, DressPack/SpotPack | 3HAC17290-7 | The contents are defined in section Toolkits, DressPack/SpotPack on page 257 . |
| Toolkit cables | | The contents are defined in section Toolkit cables . |
| Other tools and procedures may be required. See references to these procedures in the step-by-step instructions below. | | These procedures include references to the tools required. |
| Cable grease | - | Optitemp RB1 |
| Protective plastic | - | To protect the connector pins during disassembly. |
| Circuit Diagram | 3HAC026136-001 3HAC026208-001 | |

Disassembly

The procedure below details how to disassemble the DressPack cable package.

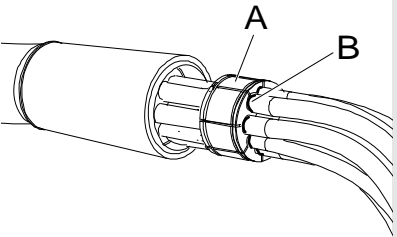
| Action | Note |
|---|---|
| 1.  CAUTION! The cable package is sensitive to mechanical damage. They must be handled with care, especially the connectors, in order to avoid damaging them. | |
| 2. Remove the connectors in the tool end. | Use recommended removal tool. Detailed in section Toolkit cables . |
| 3. Put plastic film over the pins and tighten with reinforced tape. | |
| 4. Mark the position for <i>rubber retainer</i> on cables and hoses with <i>reinforced tape</i> . |  <p>xx0500001558</p> <p>Parts:</p> <ul style="list-style-type: none"> • A: Rubber retainer • B: Reinforced tape |

© Copyright 2006-2010 ABB. All rights reserved.

Continues on next page

Continued

| | Action | Note |
|-----|---|---|
| 5. | Fittings might need to be cut to get the package out from protection hose. | |
| 6. | Open up the hose clamps in both ends and dis-assembled <i>slide sleeves</i> . | Shown in the figure, <i>Upper arm cable package parts on page 195</i> |
| 7. | Remove the <i>rubber retainer</i> at tool end. | Shown in the figure, <i>Upper arm cable package parts on page 195</i> |
| 8. | Slip cables and hoses through protection hose. | |
| 9. | Rotate package if stuck. <ul style="list-style-type: none"> Avoid putting stress to signal cable. | |
| 10. | If tight: <ol style="list-style-type: none"> pull out the hoses one by one pull out the power cable pull out the signal cables. | |
| 11. | Clean cable and hoses from grease. | |
| 12. | Check carefully if cable and hoses is damaged. <ul style="list-style-type: none"> Change if required. Normally, protection hose and hose reinforcement changed at the same time | |

Refitting

The procedure below details how to refit the DressPack upper arm cable package.





| | Action | Note |
|----|---|------|
| 1. |  <p>CAUTION! The cable package is sensitive to mechanical damage. They must be handled with care, especially the connectors, in order to avoid damaging them.</p> | |
| 2. | Do not twist hoses and cables inside the protective hose. | |
| 3. | Measure and mark proper position for front and rear rubber retainer with reinforced tape. | |
| 4. | Assemble rear rubber retainer. <ul style="list-style-type: none"> Check the individual order related to the rubber retainer and between the different parts. | |

Continues on next page

4 Repair

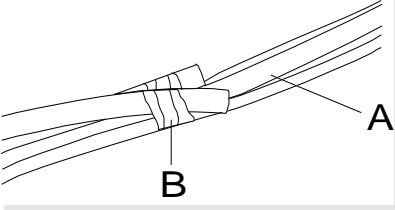

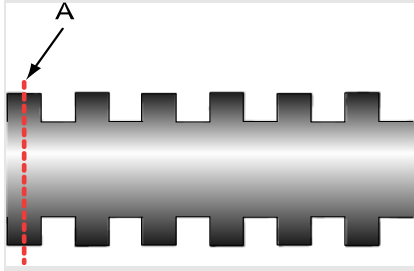
4.2.8. Repair of process cable package

Continued

| Action | Note |
|--|---|
| <p>5. Secure related positions by reinforced tape.</p> <p> NOTE! Put the reinforced tape at parts that will end outside the protective hose.</p> |  <p>xx0500001559</p> <p>Parts:</p> <ul style="list-style-type: none"> • A: Cables and hoses • B: Reinforced tape |
| <p>6. Apply cable grease on cables and hoses.</p> <p> NOTE! Do not apply grease closer than the 100 mm from cable and rubber retainers, and it is very important that grease is not present on the hoses and cable inside the rubber retainer.</p> | |
| <p>7. Put cables and hoses on a flat and clean surface.</p> | |
| <p>8. Straighten weld cable, signal cables and hoses.</p> | |
| <p>9. Inspect the protective hose to make sure its ends has been correctly cut.</p> |  <p>xx0300000061</p> <p>Parts:</p> <ul style="list-style-type: none"> • A: Place where to cut the protective hose (on top of a ridge). |
| <p>10. Fit <i>hose reinforcement</i> to <i>protective hose</i>.</p> | <p>Detailed in section, Upper arm cable package parts on page 195</p> |
| <p>11. Slip cables and hoses inside protective hose.</p> <p> NOTE! Keep cables and hoses straight during assembly, and not lose orientation relative each other during assembly.</p> | |
| <p>12. Assemble rubber retainer at the tools side with the same orientation as the rear one.</p> | |

© Copyright 2006-2010 ABB. All rights reserved.

Continues on next page

| | Action | Note |
|-----|--|--|
| 13. | Remove reinforced tape when slide sleeves are assembled. | |
| 14. | Straighten package well and double-check measurements.  NOTE! Protective hose should be measured in released mode and not after being stretched. | |
| 15. | Assemble front rubber retainer. <ul style="list-style-type: none"> Open up front rubber retainer on the tool side and push signal cables back 50 mm into the protection hose.  NOTE! The weld cable should not be pushed in the protective hose. Rubber retainers in combination with hoses and weld cable should take the "pulling forces" within the process cable package. The forces should not be transferred to the signal cables. | |
| 16. | Fit the slide sleeves. | Detailed in section Replacement of slide sleeves on page 208 . |
| 17. |  CAUTION! Verify that hoses can withstand 500 N static load without leading to any motion between hoses and rubber retainer relative. | |
| 18. | Remove plastic film at the tool end (avoid grease on the pins) and assemble the connectors | Use recommended insertion tool. See <i>Toolkit cables</i> . |
| 19. | Check that all cables are connected according to circuit diagram and use the proper tools | Detailed in section, Toolkits, DressPack/SpotPack on page 257 |
| 20. | Check that the strain relief for the cables are correct. | |
| 21. | Mount the fittings on the hoses and double check for leakage. | |
| 22. | If protective sleeves has been fitted, refit them at the same position as before. | |
| 23. | The package is ready for assembly on the robot. | Detailed in section, Installation activities on page 45 |

4 Repair

4.2.9. Adjusting tension arm unit

4.2.9. Adjusting tension arm unit



NOTE!

This section is not applicable to cable package IRBDP MH 3 UE.

Location of tension arm unit

This section details how to adjust the tension arm unit.

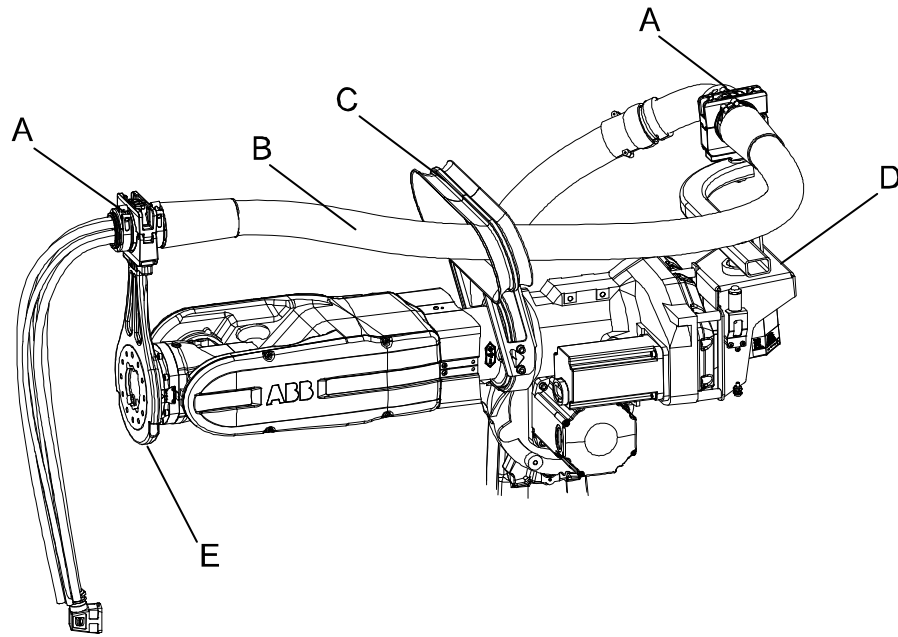

xx0600003167

| | |
|---|-------------------------------|
| A | Slide sleeve slide surface |
| B | Process cable package |
| C | Hose support |
| D | Tension arm unit |
| E | Process cable support, axis 6 |

General

Spring tension has influence on lifetime of the upper arm harness and shall not be higher than necessary.

Tension is optimized for normal length of upper arm harness working vertically.

- The arm of the retracting unit shall "float" a little when the robot is moving.

Required equipment

| Equipment | Note |
|--------------------------------------|--|
| Standard tool kit DressPack/SpotPack | The contents are defined in section Toolkits, DressPack/SpotPack on page 257 . |

© Copyright 2006-2010 ABB. All rights reserved.

Continues on next page

Adjustment values



At delivery all tension arm are pre-tensioned 3/4 of a turn.

Spring force must be adjusted to fit valid cycle. Approximate values:

- SpotWelding ~ 3/4 turn
- Material Handling ~ 1/2 - 3/4 turn

Procedures

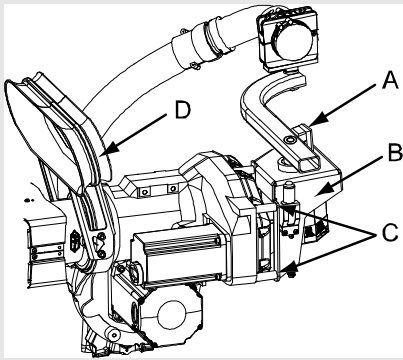

The procedure below details how to adjust the tension arm unit spring.

| | Action | Note |
|----|--|---|
| 1. |  <p>DANGER! Turn off all electric power, hydraulic and pneumatic pressure supplies to the robot! For Foundry Prime robots: Do not turn off the air pressure to motors and SMB.</p> | |
| 2. |  <p>WARNING! In order to avoid accidents place the robot in a service position (upper arm slightly upwards) with the <i>tension arm</i> resting against the <i>damper</i>.</p> |  <p>xx0600003179</p> <p>Parts:</p> <ul style="list-style-type: none"> • A: Damper • B: Tension arm unit • C: Attachment screws (3 pcs) • D: Hose support |

4 Repair

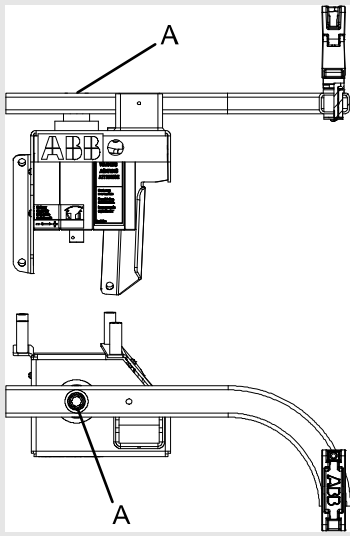

4.2.9. Adjusting tension arm unit

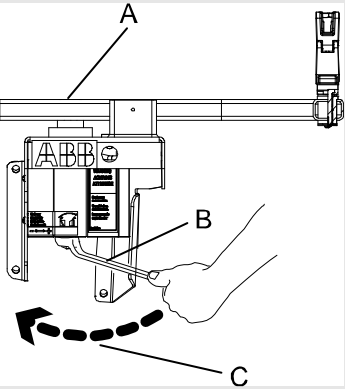
Continued

| | Action | Note |
|----|---|--|
| 3. | Loosen the <i>upper screw (M12)</i> , with a 18 mm standard wrench approximately 10-15 mm. |  <p>xx0600003192</p> <p>Parts:</p> <ul style="list-style-type: none"> A: Upper screw M12x220 (4 pcs) |
| 4. |  <p>TIP! The next step is best performed by two persons working together.</p> | |
| 5. | <p>Release the tension in the spring bolt with a 27 mm <i>standard wrench</i>, while tapping the <i>upper screw</i> with a rubber mallet.</p>  <p>NOTE! Hold the wrench in a firm position as the spring force now will try to rotate the wrench to the left.</p> |  <p>xx0600003182</p> <p>Parts:</p> <ul style="list-style-type: none"> A: Upper screw M12 B: Standard wrench (27 mm) C: Direction in which the spring force will rotate the wrench |
| 6. | <p>To <i>increase</i> the force: pull the wrench right. To <i>decrease</i> the force: push the wrench left.</p> | |

© Copyright 2006-2010 ABB. All rights reserved.

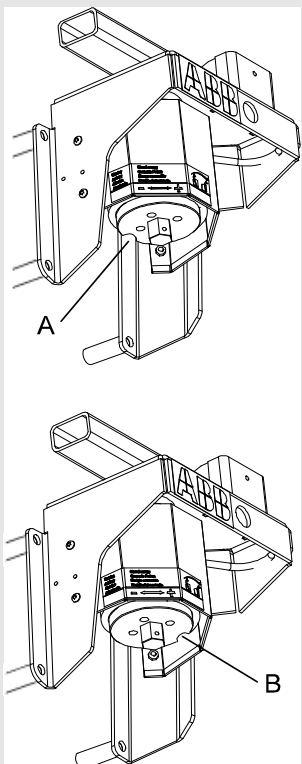
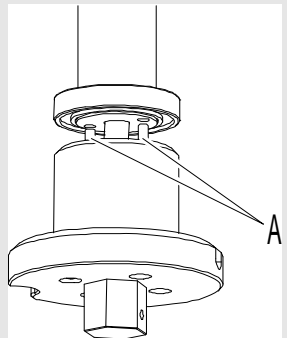
Continues on next page

| | Action | Note |
|-----------|---|--|
| | <p>7. Carefully lower the spring and use the wrench to adjust appropriate spring force.</p> |  <p>xx0600003193</p> <p>View:</p> <ul style="list-style-type: none"> • A: Showing the spring with no tension • B: Showing the spring with $\frac{3}{4}$ tension (270°). |
| | <p>8. Secure the spring force by lifting up the spring and fit into hole circle. The spring could be set in steps of 1/8 of a turn.</p> | <p>View of inside.</p>  <p>xx0500001509</p> <ul style="list-style-type: none"> • A: Guide pins |
| <p>9.</p> |  <p>TIP! The next step is best performed by two persons working together.</p> | |

4 Repair

4.2.9. Adjusting tension arm unit

Continued

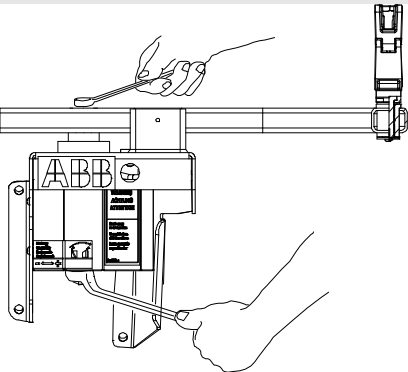
| | Action | Note |
|-----|---|---|
| 10. | Fasten the spring by tightening the upper screw (M12) while holding the spring bolt in a firm position. |  <p data-bbox="991 734 1098 752">xx0600003183</p> |

4.3 DressPack cable package, common

4.3.1. Replacement of hose reinforcement



NOTE!

This section is not applicable to cable package IRBDP MH 3 UE.

Overview

All work detailed below is to be performed on a workbench!

How to remove the DressPack harness from the robot is detailed in section [Replacement of cable package IRBDP MH2 CE and IRBDP SW2 CE](#) on page 171.

Location of hose reinforcement

The hose reinforcement is located as shown in the figure below.

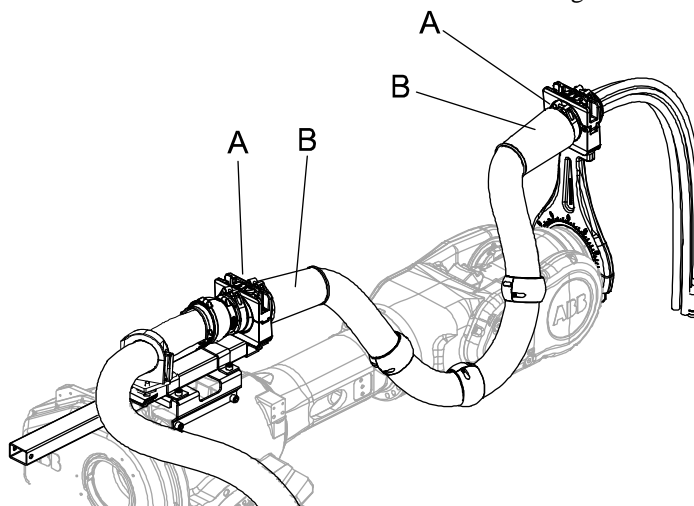

xx0800000089

IRBDP SW 5 CE

| | |
|---|--------------------|
| A | Slide sleeves |
| B | Hose reinforcement |

4 Repair

4.3.1. Replacement of hose reinforcement

Continued

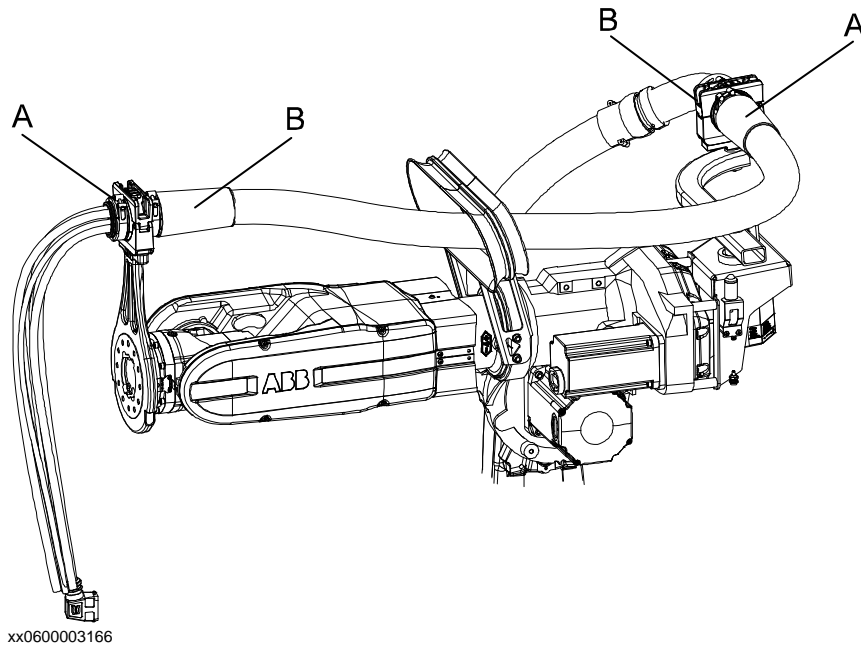

xx0600003166

| | |
|---|--------------------|
| A | Slide sleeves |
| B | Hose reinforcement |

Required equipment

| Equipment, etc. | Spare part no. | Art. no. | Note |
|--|----------------|-------------|--|
| Hose reinforcement | 3HAC022194-001 | | |
| Standard Toolkit, DressPack/SpotPack | | 3HAC17290-7 | The contents are defined in section Toolkits, DressPack/SpotPack on page 257 . |
| Other tools and procedures may be required. See references to these procedures in the step-by-step instructions below. | | - | These procedures include references to the tools required. |

© Copyright 2006-2010 ABB. All rights reserved.

Continues on next page

Removal

The procedure below details how to remove the hose reinforcement.

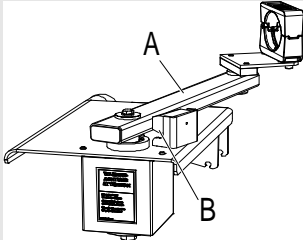
| | Action | Note |
|----|--|--|
| 1. | <p>(Not applicable to cable package IRBDP SW 5 CE)</p>  <p>WARNING!</p> <p>The tension arm unit pulls the hose package backwards! Hence, in order to avoid accidents, the robot must be positioned in a way that the arm of the tension arm unit is placed in its rear position.</p> <p>The <i>tension arm</i> must rest on the <i>damper</i> before the disassembly of the upper arm starts!</p> |  <p>xx0500001794</p> <p>Parts:</p> <ul style="list-style-type: none"> • A: Tension arm • B: Damper |
| 2. | <p>Perform the procedure detailed in section Replacement of cable package IRBDP MH2 CE and IRBDP SW2 CE on page 171 and the first steps of the procedure detailed in section Repair of process cable package on page 195.</p> <p>This will give access to the slide sleeves.</p> | <p>Detailed in section Replacing the cable package IRBDP SW5 CE (SpotPack Basic) on page 185.</p> |
| 3. | <p>Pull the hose reinforcements off the protective hose.</p> | <p>Make sure that the protective hose is not damaged.</p> <p>If the protective hose is damaged, replace it!</p> |

Refitting

The procedure below details how to refit the hose reinforcement.

| | Action | Note |
|----|--|---|
| 1. | <p>Select the hose reinforcement.</p> | <p>Article number is specified in the <i>Spare parts</i> chapter.</p> |
| 2. | <p>Gently push the hose reinforcement on to the protective hose.</p> | <p>Make sure the hose reinforcement rib align with the slide sleeve on assembly.</p> |
| 3. | <p>Perform the last steps of the procedure Repair of process cable package on page 195 and the procedure detailed in section Fitting the cable package IRBDP SW2 CE IRBDP MH2 CE and on page 67.</p> | <p>Detailed in section Repair of process cable package on page 195.</p> <p>Detailed in section Replacing the cable package IRBDP SW5 CE (SpotPack Basic) on page 185.</p> |

4 Repair

4.3.2. Replacement of slide sleeves

4.3.2. Replacement of slide sleeves



NOTE!

This procedure is not applicable to cable package IRBDP MH 3 UE.

Location of slide sleeves

The slide sleeves are located as shown in the figure below.

Replacement of slide sleeves is possible to be performed without removing the DressPack from the robot. However replacement may also be performed on a work bench. How to remove the DressPack from the robot is detailed in section *Replacement of cable package IRBDP MH2 CE and IRBDP SW2 CE on page 171*.

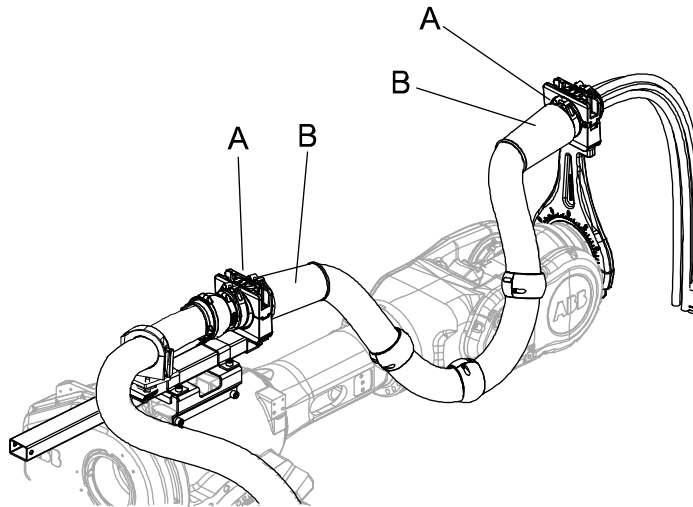

xx080000089

IRBDP SW 5 CE

| | |
|---|--------------------|
| A | Slide sleeves |
| B | Hose reinforcement |

Continued

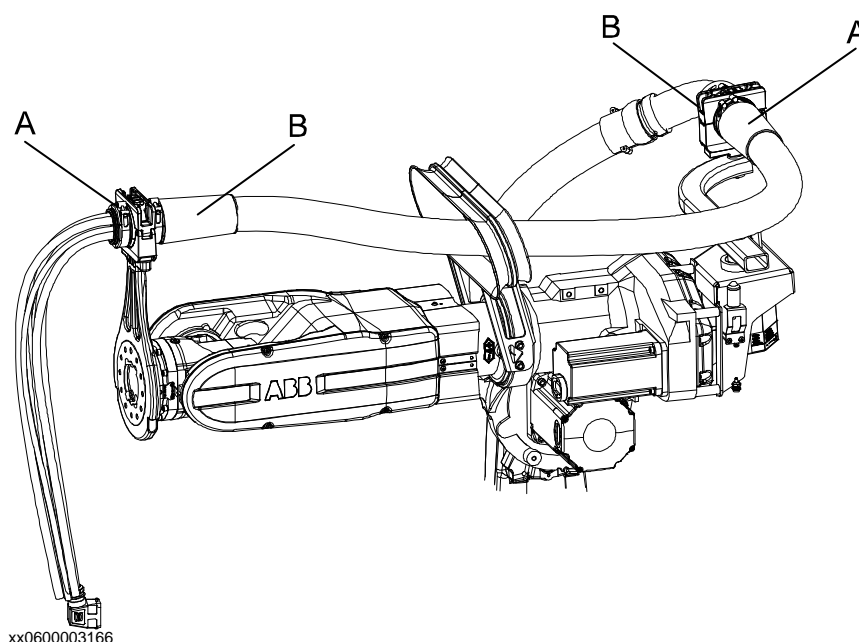

xx0600003166

| | |
|---|--------------------|
| A | Slide sleeves |
| B | Hose reinforcement |

Required equipment

| Equipment, etc. | Art. no. | Note |
|--|-------------|---|
| Slide sleeves | 3HAC16208-1 | |
| Standard Toolkit, DressPack/ SpotPack | 3HAC17290-7 | The contents are defined in section Toolkits, DressPack/SpotPack on page 257. |
| Other tools and procedures may be required. See references to these procedures in the step-by-step instructions below. | - | These procedures include references to the tools required. |

Removal

The procedure below details how to remove the slide sleeves.



| | Action | Note |
|----|---|------|
| 1. | Move the robot to a position where the upper arm is pointing slightly upwards and the tension arm unit is resting against the damper. | |

Continues on next page

4 Repair

4.3.2. Replacement of slide sleeves

Continued

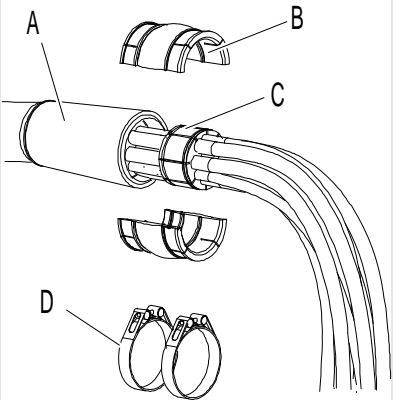
| | Action | Note |
|----|--|---|
| 2. |  <p>DANGER! Turn off all electric power, hydraulic and pneumatic pressure supplies to the robot! For Foundry Prime robots: Do not turn off the air pressure to motors and SMB.</p> | |
| 3. |  <p>CAUTION! The cable package is sensitive to mechanical damage. They must be handled with care, especially the connectors, in order to avoid damaging them.</p> | |
| 4. | Mark the positions of the rubber grommets on cables and hoses with reinforced tape. | |
| 5. | Disconnect all hose and cable connectors. | This is only needed if the work is going to be done on a workbench. |
| 6. | Open ball joint housings. | |
| 7. | Remove the process cable from the ball joint housings. | |
| 8. | Open the <i>hose clamps</i> . |  <p>xx0500001795</p> <p>Parts:</p> <ul style="list-style-type: none"> • A: Hose reinforcement • B: Slide sleeve • C: Rubber grommet • D: Hose clamp |
| 9. | Remove and replace the slide sleeves, one at a time. | |

© Copyright 2006-2010 ABB. All rights reserved.

Continues on next page

Refitting

The procedure below details how to refit the slide sleeves.

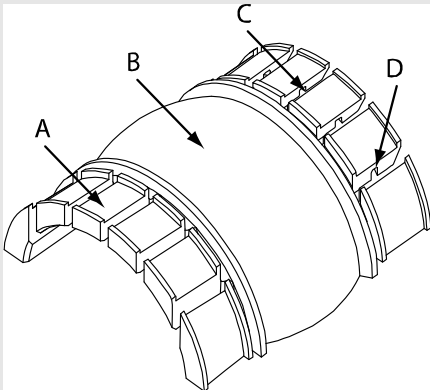
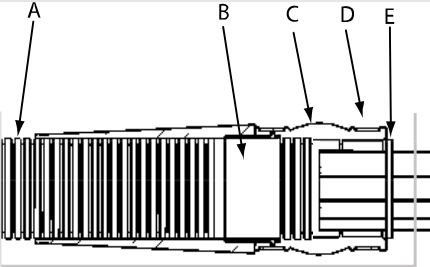
| | Action | Note |
|--|---|---|
| | <p>1. Refit the slide sleeves over the hose reinforcement. Make sure the slide sleeves are turned the right way.</p> |  <p>xx0300000249</p> <p>Parts:</p> <ul style="list-style-type: none"> • A: Hose clamp surface, farthest from the protective hose • B: Slide sleeve slide surface, slightly concave • C: Hose clamp surface, closest to the protective hose • D: Groove for locking the hose reinforcement |
| | <p>2. The figure to the right, shows the fitting positions of the <i>slide sleeves</i> on the <i>cable/hose retainer</i>.</p> | <p>The figure shows a cross section of the slide sleeves:</p>  <p>xx0400001007</p> <p>Parts:</p> <ul style="list-style-type: none"> • A: Protective hose • B: Hose reinforcement • C: Slide sleeves • D: Hose clamp • E: Cable/Hose retainer |

4 Repair

4.3.2. Replacement of slide sleeves

Continued

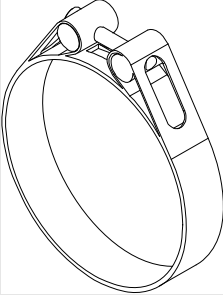
| | Action | Note |
|----|--|--|
| 3. | <p>Secure the slide sleeves with <i>hose clamps</i>. In applications where a large number of cables/hoses are used, aluminum cable clamps may be used, to compress the entire package.</p> <p>The slide sleeves are correctly tightened when a fully tightened aluminum cable clamp (for example on the tension arm unit) and the process cable support axis 6 allows some swivelling.</p> | <p>Make sure both clamps face the same way!</p> <p>Make sure the gaps between the slide sleeve halves are close to identical and <i>do not coincide</i> with the vertical cuts in the hose and cable retainer!</p>  <p>xx0300000250</p> <ul style="list-style-type: none">• Hose clamp |
| 4. | Check that the cables and hoses are in the right position. | Use the makings of the reinforced tape done earlier. |
| 5. | Refit the cable package in the ball joint housing. | |
| 6. | Reconnect cable and hose connectors. | |

4.4 Water and Air unit

4.4.1. Replacement of Air supply circuit

Location of Air supply circuit, type S

The Air supply circuit is located as shown in the figure below.

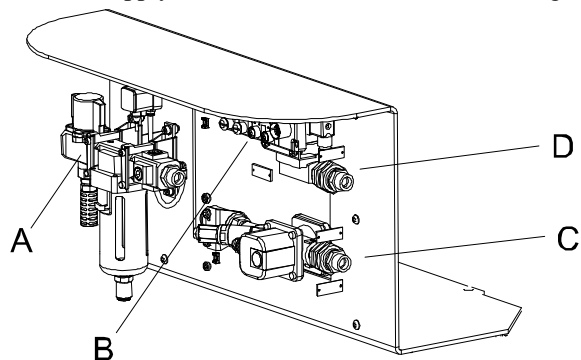

xx0600003293

The figure shows the Air supply circuit *without* Electrical Proportional valve.

| | |
|---|----------------------|
| A | Air supply circuit |
| B | Split box |
| C | Water return circuit |
| D | Water in circuit |

Location of Air supply circuit, type Sb

The Air supply circuit is located as shown in the figure below.

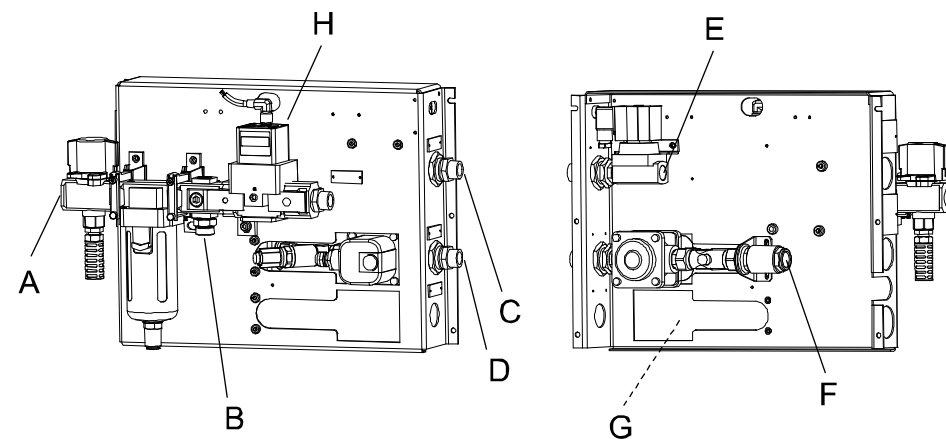

xx0800000124

| | |
|---|------------------------------------|
| A | Air supply circuit |
| B | PROC 1 on robot base |
| C | PROC 2 on robot base |
| D | PROC 3 on robot base |
| E | Shop water supply |
| F | Shop water drain |
| G | PROC 4 on robot base (option) |
| H | Electrical Proportional Valve (EP) |

Continues on next page

4 Repair

4.4.1. Replacement of Air supply circuit

Continued

Required equipment

| Equipment | Art. no. | Note |
|--------------------------------------|---------------------------------|--|
| Water and air unit | See <i>Spare parts</i> section. | A number of versions are available. The Water and Air unit assembly contains all required hardware for fitting and connecting. |
| Standard toolkit, DressPack/SpotPack | 3HAC17290-7 | The contents are defined in section Toolkits, DressPack/SpotPack on page 257 . |
| Circuit diagram | 3HAC026208-001 | SpotPack |

Removal

The procedure below details how to remove the Air Supply Circuit. It does not deal with details specific to each version, such as article numbers, connector types etc. For details see the *Spare parts* section.

| | Action | Note |
|-----|---|--|
| 1. |  CAUTION! The system contains compressed air! Observe the safety information in section Safety risks related to pneumatic/hydraulic systems on page 21 . | |
| 2. | Turn off the hand operated air valve on the air supply circuit. | The air hoses on the robot will be decompressed. |
| 3. | Turn off the shop floor air supply to the Water and Air unit. | |
| 4. | Remove the hose of the compressed air supply of the workshop. | |
| 5. | Remove the Proc 1 hose from the air supply unit. | |
| 6. | Remove the Proc 4 hose from the air supply unit. | Only if the option Proportional valve has been selected. |
| 7. | Disconnect the pressure switch tube from the Air circuit Cross interface. | |
| 8. | Disconnect the pressure switch connector on the split box, according to the circuit diagram. | |
| 9. | Disconnect the pressure switch from the mounting plate. | |
| 10. | If the option proportional valve is selected, disconnect the proportional valve connectors on the split box according to the circuit diagram. | |
| 11. | Unscrew the four attachment screws holding the air supply circuit and remove it. | |

© Copyright 2006-2010 ABB. All rights reserved.

Continues on next page

Refitting

The procedure below details how to refit the air supply circuit. It does not deal with details specific to each version, such as article numbers, connector types etc. For details see the *Spare parts* section.

| | Action | Note |
|-----|--|--|
| 1. | Fit the air supply circuit with its four attachment screws. | |
| 2. | Connect the proportional valve connectors on the split box according to the circuit diagram. | Only if the option Proportional valve has been selected. |
| 3. | Connect the pressure switch to the mounting plate. | |
| 4. | Connect the pressure switch connector on the split box according to the circuit diagram. | |
| 5. | Connect the pressure switch tube from the Air circuit Cross interface. | |
| 6. | Connect the Proc 4 hose from the Air supply unit. | Only if the option Proportional valve has been selected. |
| 7. | Connect the Proc 1 hose from the Air supply unit. | |
| 8. | Connect the hose of the compressed air supply of the workshop. | |
| 9. | Turn on the air supply to the Water and Air unit. | |
| 10. | Turn on the hand operated air valve on the air supply circuit. | The hoses at the robot will be compressed. |
| 11. | Check for leakages! | Tighten if there is leakage. |

4 Repair

4.4.2. Replacement of Water-in circuit

4.4.2. Replacement of Water-in circuit

Location of Water-in circuit, type S

The water in circuit is located on the rear side of the Water and air unit as shown in the figure below.

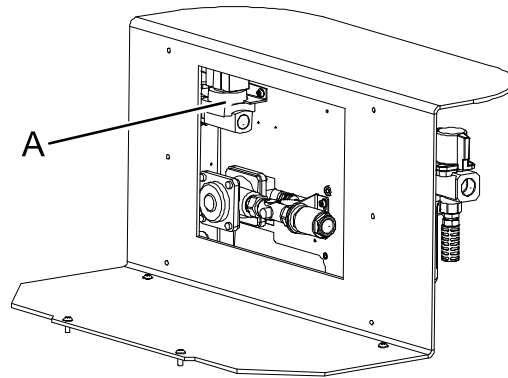

xx0600003462

| | |
|---|------------------|
| A | Water-in circuit |
|---|------------------|

Location of Water-in circuit, type Sb

The water in circuit is located on the rear side of the Water and air unit as shown in the figure below.

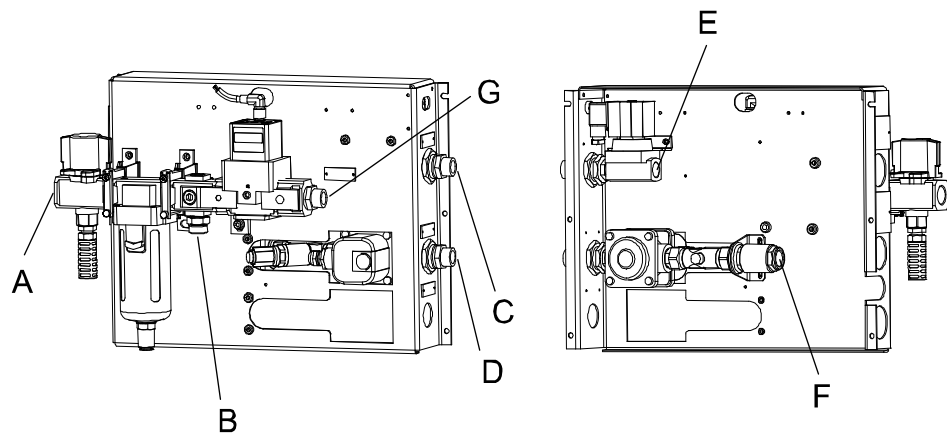

xx0800000122

| | |
|---|-------------------------------|
| A | Air supply circuit |
| B | PROC 1 on robot base |
| C | PROC 2 on robot base |
| D | PROC 3 on robot base |
| E | Water-in circuit |
| F | Water drain |
| G | PROC 4 on robot base (option) |

© Copyright 2006-2010 ABB. All rights reserved.

Continues on next page

Required equipment

| Equipment | Art. no. | Note |
|--------------------------------------|---------------------------------|--|
| Water and Air unit | See <i>Spare parts</i> section! | A number of versions are available. The Water and Air unit assembly contains all required hardware for fitting and connecting. |
| Standard toolkit, DressPack/SpotPack | 3HAC17290-7 | The contents are defined in section Toolkits, DressPack/SpotPack on page 257 . |
| Circuit diagram | 3HAC026208-001 | SpotPack |

Removal

The procedure below details how to remove the water-in circuit. It does not deal with details specific to each version, such as article numbers, connector types etc. For details see the *Spare parts* section.

| | Action | Note |
|----|--|------|
| 1. | Turn off the water supply to the Water and Air unit. | |
| 2. | Remove the hose of the water supply of the workshop to the Water-in circuit. | |
| 3. | Remove the Proc 2 hose from the Water and Air unit. | |
| 4. | Remove the Pushlok nipple. | |
| 5. | Loosen the locking nut. | |
| 6. | Unscrew the two attachment screws holding the water-in circuit. | |
| 7. | Remove the Water-in circuit from the mounting plate. | |
| 8. | Remove the DIN-connector from the electrical water valve. | |

Refitting

The procedure below details how to refit the water-in circuit. It does not deal with details specific to each version, such as article numbers, connector types etc. For details see the *Spare parts* section.

| | Action | Note |
|----|--|---------------------------------|
| 1. | Attach the DIN-connector to the electrical water valve. | |
| 2. | Fit the water-in circuit with its two attachment screws on the mounting plate. | |
| 3. | Tighten the locking nut. | |
| 4. | Fit the Pushlok nipple. | |
| 5. | Connect the Proc 2 hose on the Water and Air unit. | |
| 6. | Connect the hose of the workshop water supply to the Water-in circuit. | |
| 7. | Turn on the water supply to the Water and Air unit. | |
| 8. | Check for leakages. | Tighten if there are any leaks. |

4 Repair

4.4.3. Replacement of Water-return circuit

4.4.3. Replacement of Water-return circuit

Location of Water-return circuit, type S

The Water-return circuit (or circuits) is located on the rear side of the Water and air unit as shown in the figure below.

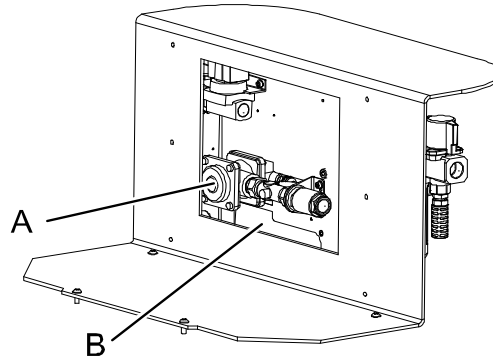

xx0600003464

| | |
|---|--|
| A | Water-return circuit |
| B | Position for second Water-return circuit |

Location of Water-return circuit, type Sb

The Water-return circuit (or circuits) is located on the rear side of the Water and air unit as shown in the figure below.

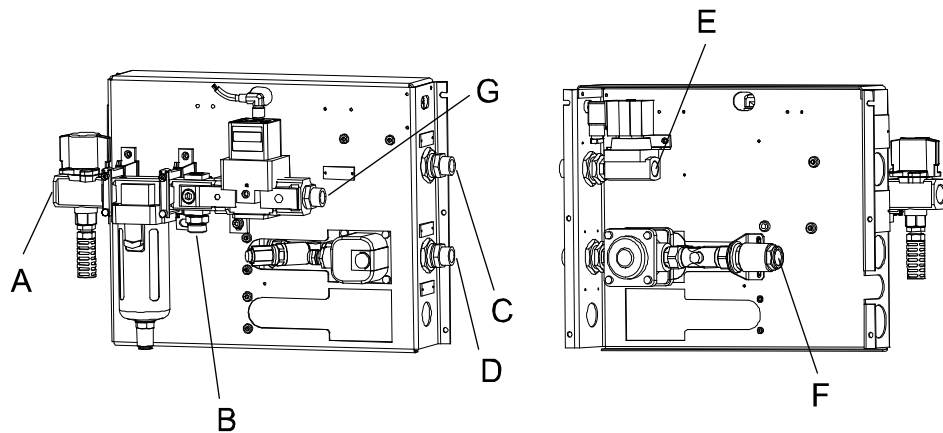

xx0800000122

| | |
|---|-------------------------------|
| A | Air supply circuit |
| B | PROC 1 on robot base |
| C | PROC 2 on robot base |
| D | PROC 3 on robot base |
| E | Water-in circuit |
| F | Water-return circuit |
| G | PROC 4 on robot base (option) |

© Copyright 2006-2010 ABB. All rights reserved.

Continues on next page

Continued

Required equipment

| Equipment | Art. no | Note |
|--------------------------------------|--------------------------|--|
| Water and Air unit | See Spare Parts section. | A number of versions are available. The Water and Air unit assembly contains all required hardware for fitting and connecting. |
| Standard toolkit, DressPack/SpotPack | 3HAC17290-7 | The contents are defined in section Toolkits, DressPack/SpotPack on page 257 . |
| Circuit diagram | 3HAC026208-001 | SpotPack |

Removal

The procedure below details how to remove the water-return circuit. It does not deal with details specific to each version, such as article numbers, connector types etc. For details see *Spare parts* section.

| | Action | Note |
|-----|--|--|
| 1. | Turn off the water supply to the Water and Air unit. | |
| 2. | Turn off the shop water drain from the Water and Air unit. | |
| 3. | Remove the hose of the shop floor water drain from the Water-return circuit. | One water-return: <ul style="list-style-type: none"> Disconnect the hose from the check valve Second water-return: <ul style="list-style-type: none"> Disconnect the hose from the bulkhead connector. |
| 4. | Loosen the locking nut. | Only if the option <i>Second water return</i> has been selected. |
| 5. | Remove the Proc 3 hose from the Water and Air unit. | |
| 6. | Remove the Proc 4 hose from the Water and Air unit. | Only if the option <i>Second water return</i> has been selected. |
| 7. | Remove the Pushlok nipple (or nipples) for return water. | |
| 8. | Loosen and remove the locking nut (or nuts). | |
| 9. | Unscrew the two attachment screws securing the mounting bracket (or brackets). | |
| 10. | Remove the Water-return circuit (or circuits) from the mounting plate. | |

Refitting

The procedure below details how to refit the water-return circuit. It does not deal with details specific to each version, such as article numbers, connector types etc. For details see *Spare parts* section.

| | Action | Note |
|----|---|------|
| 1. | Place the Water-return circuit (or circuits) on the mounting plate. | |

Continues on next page

4 Repair

4.4.3. Replacement of Water-return circuit

Continued

| | Action | Note |
|-----|--|--|
| 2. | Fit the two attachment screws securing the mounting bracket (or brackets). | |
| 3. | Fit and tighten the locking nut (or nuts). | |
| 4. | Fit the Pushlok nipple (or nipples). | |
| 5. | Connect the Proc 3 hose from the Water and Air unit. | |
| 6. | Connect the Proc 4 hose from the Water and Air unit. | Only if the option <i>Second water return</i> has been selected. |
| 7. | Tighten the locking nut, at the shop floor side. | Only if the option <i>Second water return</i> has been selected. |
| 8. | Connect the hose of the shop water drain to the water-return circuit. | |
| 9. | Turn on the water supply to the Water and Air unit. | |
| 10. | Activate the electrical valve. | |
| 11. | First turn on and then turn off the shop water drain. | This is done in order to evacuate all air in the circuit. |
| 12. | Wait a couple of minutes and check for leakage. | Tighten if there is any leakage. |
| 13. | Turn on the shop water drain. | |

4.4.4. Replacement of Air filter element

Replacement of air filter

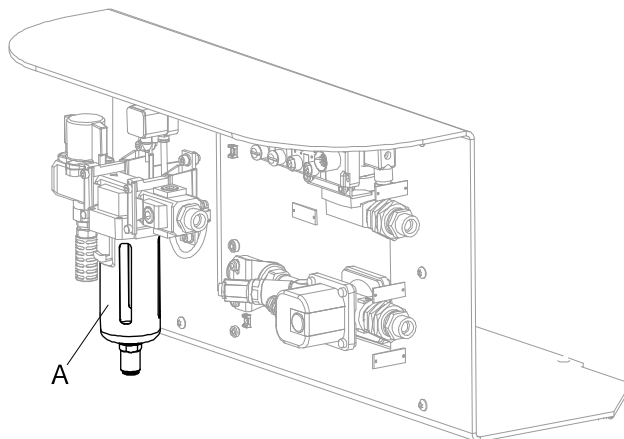

xx0700000400

Type S

| | |
|---|------------|
| A | Air filter |
|---|------------|

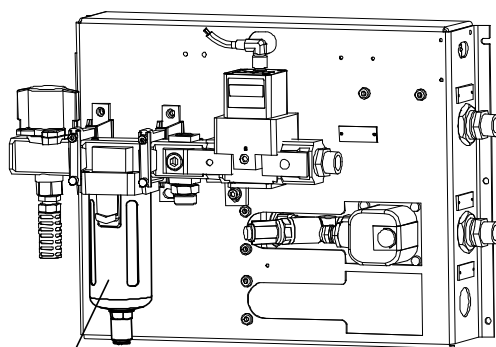

xx0800000125

Type Sb

| | |
|---|------------|
| A | Air filter |
|---|------------|

The procedure below details how to replace the air filter element on the Water and Air unit.

| Action | Note |
|--|------|
| 1. Turn off the hand operated air valve and make sure that the air filter is not pressurized. | |
| 2. Remove the bowl assembly, by following these steps: <ul style="list-style-type: none"> • Push the bowl assembly lock button. • Lift the bowl assembly. • Rotate the bowl assembly 45° (right or left). • Pull out the assembly. | |
| 3. Remove the baffle, filter element and deflector by rotating the baffle counterclockwise by hand. | |

Continues on next page

4 Repair

4.4.4. Replacement of Air filter element

Continued

| | Action | Note |
|----|--|--|
| 4. | Fit the deflector to the body assembly. Mind the fitting direction of the deflector (concave in which the element goes into). | Deflector direction: Concave, facing the filter element. |
| 5. | Fit the new filter element by inserting it to the deflector concave. | |
| 6. | Fit the baffle by inserting it to the filter element. Mind the fitting direction of the baffle (convex to which the element goes). | Baffle direction: Convex, facing the filter element. |
| 7. | Tighten the baffle to settle the baffle, filter element and deflector by rotating the baffle counterclockwise until it contacts the element and deflector lightly. Rotate approximately one half revolution counterclockwise further in order to tighten them. | Tightening torque: 0.9 Nm |
| 8. | Fit the bowl assembly. Match the mating mark of the body and the bowl assembly to insert the assembly to the body. Rotate the assembly 45° (right or left) until the lock button is tossed up to fit the bowl assembly. |  NOTE! Check that the lock button has tossed up! |

4.5 Spotwelding cabinet

4.5.1. Replacement of Weld Timer

Overview

The section below details how to replace the weld timer.

Location

The figure shows the spotwelding cabinet, standard.

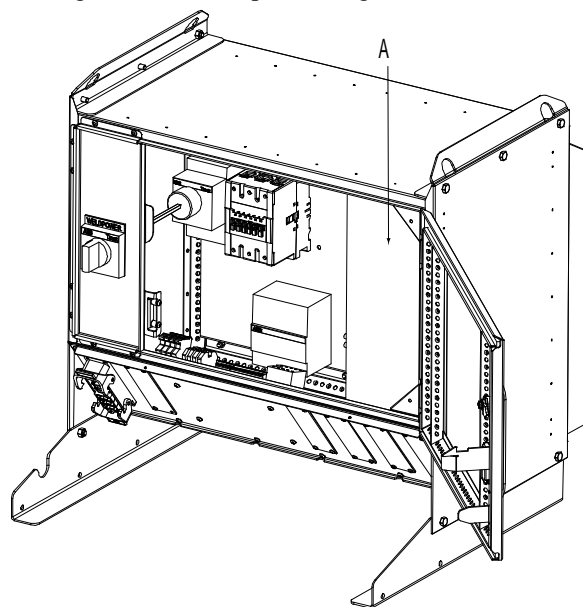

en0500001868

| | Description | Max current | |
|---|--|--|------------------------------------|
| A | Spotwelding cabinet, Standard. Weld Timer Bosch: <ul style="list-style-type: none"> • PST 6100.630 L1, (Tyristor) • PSI 6100.630 L1, (Inverter) | 130 A rms 100 kVA transformer 110 A rms 40 kVA weld current | Bosch Basic AC Bosch Basic MFDC |
| A | Spotwelding cabinet: SpotPack Basic. Weld Timer Bosch: <ul style="list-style-type: none"> • PST 610E L, (Tyristor) | 130A rms 95 kVA transformer | Bosch Compact AC |

Required equipment

| Equipment | Art. no. | Note |
|---------------------------------------|----------------------------------|---|
| Standard toolkit DressPack/ SpotPack. | 3HAC17290-7 | The contents are defined in section Toolkits, DressPack/ SpotPack on page 257 . |
| Circuit diagram | 3HAC026136-001 3HAC026208-001 | See the chapter Circuit diagram . |

Continues on next page



4 Repair

4.5.1. Replacement of Weld Timer

Continued

Removal

The following procedures details how to remove the weld timer.

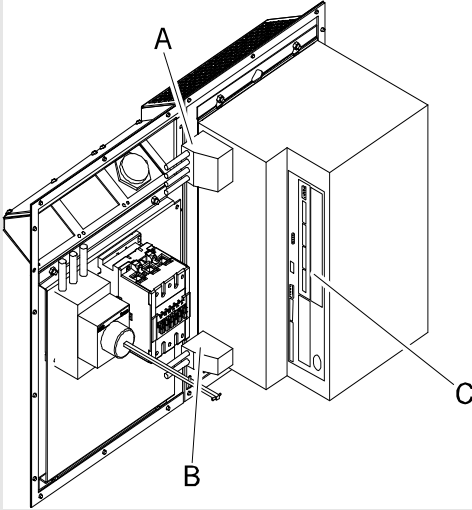
| | Action | Note |
|----|---|--|
| 1. |  DANGER! Before any work inside the cabinet, please observe the safety information in the section <i>DANGER - Make sure that the main power has been switched off</i> in the Product manual for the controller cabinet IRC5 | |
| 2. |  esd WARNING! The unit is sensitive to ESD. Before handling the unit please read the safety information in the section <i>The unit is sensitive to ESD!</i> | |
| 3. | Disconnect all electrical <i>power cables</i> and <i>signal cables</i> from the weld timer. | <p>The figure below shows standard:</p>  <p>en0500001872</p> <ul style="list-style-type: none">• A: Power cables, U1A, V1A, (W1A), PE• B: Power cables, U1B, V1B• C: Signal cables |

© Copyright 2006-2010 ABB. All rights reserved.

Continued

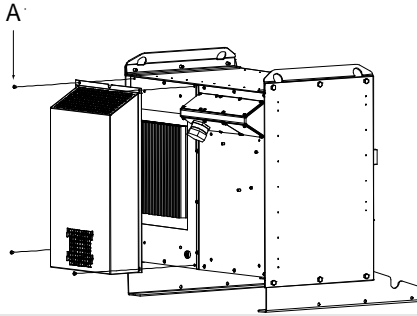
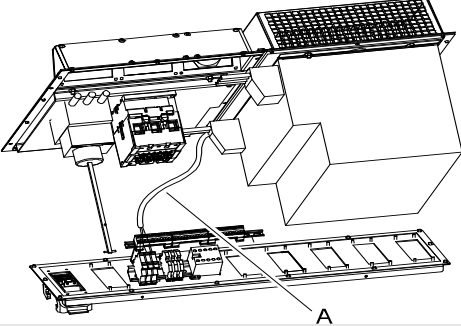
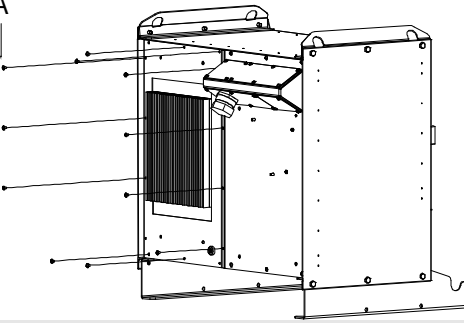
| | Action | Note |
|----|--|---|
| 4. | <p><i>(Only if a fan is fitted!)</i> Remove the <i>attachment screws</i> M5x9 Fastite (3 pcs) holding the fan cover.</p> |  <p>en0500001874</p> <p>Parts:</p> <ul style="list-style-type: none"> • A: Attachments screws |
| 5. | <p><i>(Only if a fan is fitted!)</i> Disconnect the <i>cable to fan unit</i>.</p> |  <p>en0500001878</p> <p>Parts:</p> <ul style="list-style-type: none"> • A: Cable to fan unit |
| 6. | <p><i>(Only if a fan is fitted!)</i> Remove the fan cover with the fan.</p> | |
| 7. | <p>Remove all <i>attachment screws</i> M5x9 Fastite (16 pcs) holding the rear cover.</p> |  <p>en0500001871</p> <p>Parts:</p> <ul style="list-style-type: none"> • A: Attachment screws |

4 Repair

4.5.1. Replacement of Weld Timer

Continued

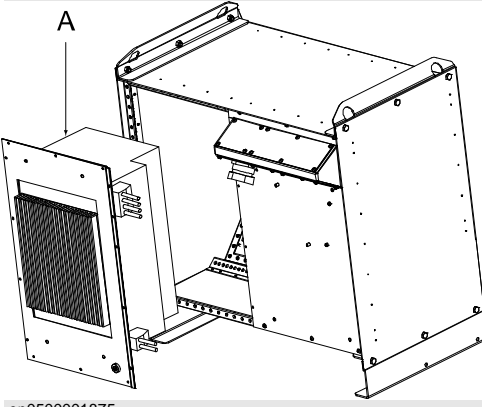
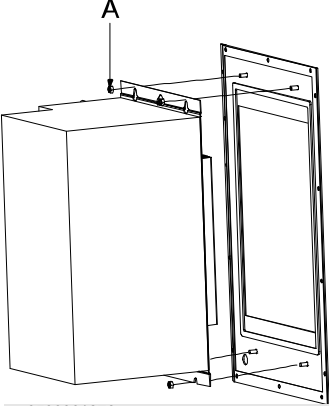
| | Action | Note |
|----|---|---|
| 8. | Remove the <i>rear cover with weldtimer</i> . |  <p>en0500001875</p> <p>Parts:</p> <ul style="list-style-type: none">• A: Rear cover with weldtimer |
| 9. | Remove the M8 <i>nut</i> quality steel 8.8-A2F(4 pcs) holding the weld timer to the rear cover. |  <p>en0500001876</p> <p>Parts:</p> <ul style="list-style-type: none">• Nut M8 (4 pcs) |

Refitting

| | Action | Note |
|----|-----------------------|--|
| 1. | Refit the weld timer. | Follow the steps in section <i>Removal</i> above in reverse order. |

4.5.2. Replacement of Bosch weld timer battery

Location

In order to buffer the RAM (contains the entire parameterization with all welding programs) and the internal clock, an integrated battery is provided.

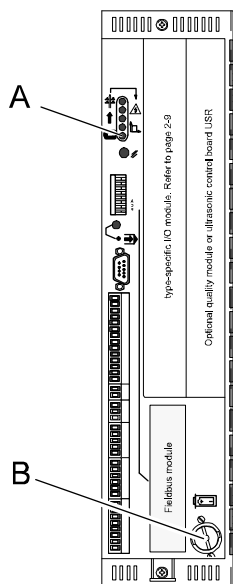

xx0500002531

Type S

| | |
|---|--|
| A | Battery error LED: RED is lit when the battery must be exchanged |
| B | Location of battery |

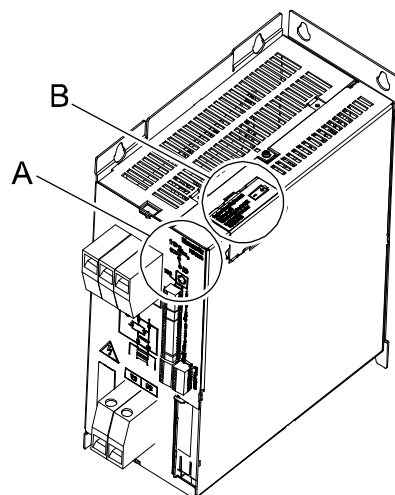

xx0800000126

Type Sb

| | |
|---|--|
| A | Battery error LED: RED is lit when the battery must be exchanged |
| B | Location of battery |

4 Repair

4.5.2. Replacement of Bosch weld timer battery

Continued

Required equipment

| Equipment | Description |
|--------------------------------------|--|
| Battery | Type: Lithium Size: AA Voltage 3.6 V Bosch no. 1070 9144446 |
| Standard SpotPack/DressPack toolkit. | The contents are defined in section Toolkits, DressPack/SpotPack on page 257 . |

Low capacity

When the remaining battery capacity becomes critical, the timer generates an error message or warning (parameterizable). The battery fault LED at the front of the timer is lit, see [Location on page 227](#). If the event has been defined as an error message, a welding process is not possible in this state.





CAUTION!

Data loss! Without a pending supply voltage and after removal of the battery, data back-up is guaranteed for up to 24 hours only. Therefore, always have at your disposal a new battery and insert it immediately upon removal of the old one.

Battery replacement

The following procedures details how to change the battery.

| | Action | Note |
|----|--|---|
| 1. |  NOTE! Replacement of battery shall be perform at least every two years! | |
| 2. |  NOTE! The battery may be replaced while the timer is running. | |
| 3. | Turn the battery cover on the timers front to the left. | Shown in the figure in Location on page 227 . |
| 4. | Remove the old battery. | |
| 5. | Insert the new battery correctly, for correct polarity. | Please refer to the illustration on the front of the timer. |
| 6. | Close the battery compartment with the battery cover. | |

© Copyright 2006-2010 ABB. All rights reserved.

4.5.3. Replacement of Circuit Breaker

Overview

The section below details how to replace the circuit breaker.

Location

The figure below shows the spotwelding cabinet, standard.

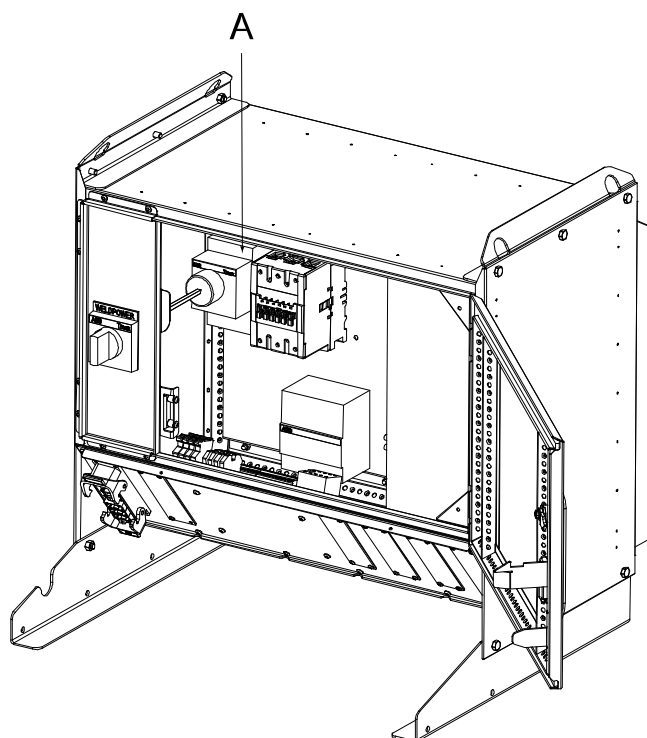

en050001880

| | |
|---|---|
| A | Circuit breaker T1N 160 F FC CU R160 (Adjustable) |
| A | Circuit breaker T2H 100 UL/CSA (Fixed) |
| A | Circuit breaker T3N 225 UL/CSA (Fixed) |

Required equipment

| Equipment | Spare part no. | Art. no. | Note |
|--|----------------|----------------------------------|--|
| Circuit breaker | 1SDA050924R1 | | T1N 160 F FC CU R160 |
| Circuit breaker | 1SDA053563R1 | | T3N 225 UL/CSA |
| Circuit breaker | 1SDA055172R1 | | T2H 100 UL/CSA |
| Standard toolkit DressPack/SpotPack | | 3HAC17290-7 | The contents are defined in section <i>Toolkits, DressPack/SpotPack</i> on page 257. |
| Circuit diagram | | 3HAC026136-001 3HAC026208-001 | |

Continues on next page

4 Repair

4.5.3. Replacement of Circuit Breaker

Continued

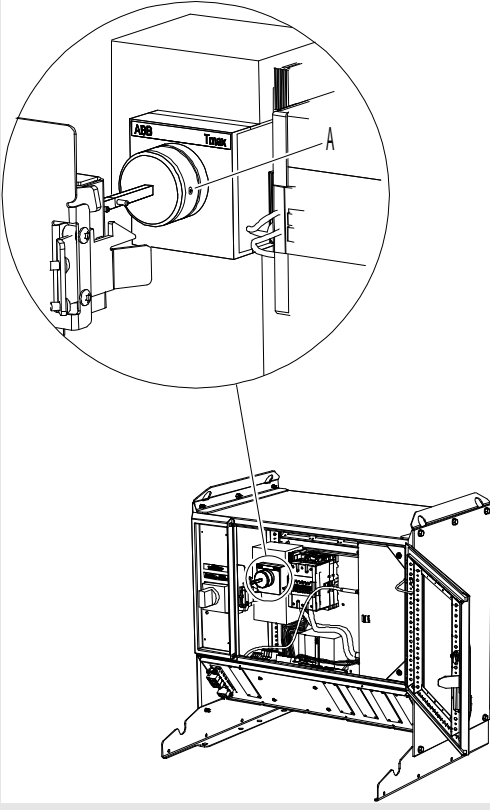

Removal

| | Action | Note |
|----|---|--|
| 1. |  DANGER! Before any work inside the cabinet, please observe the safety information in the section <i>DANGER - Make sure that the main power has been switched off</i> in the Product manual for the controller cabinet IRC5 | |
| 2. | Loosen the screw <i>locking the extension rod</i> . |  <p>xx0500002296</p> <ul style="list-style-type: none">• A: Screw locking the extension rod |

© Copyright 2006-2010 ABB. All rights reserved.

Continues on next page

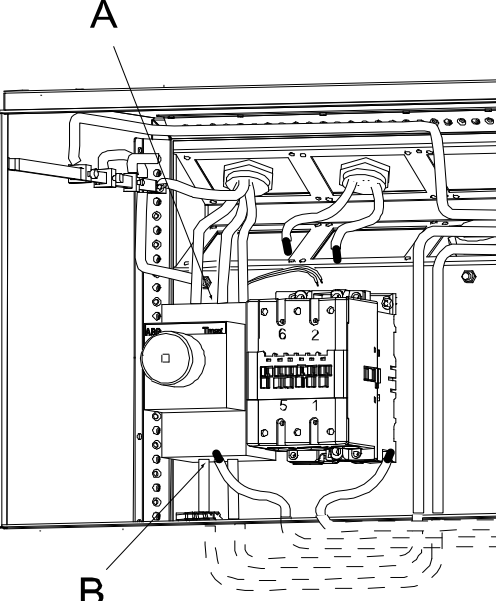
Continued

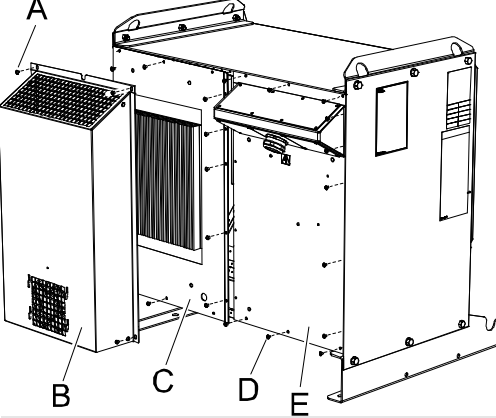
| Action | Note |
|---|---|
| <p>3. Remove all <i>terminal cables</i> attached to the circuit breaker.</p> |  <p>A</p> <p>B</p> <p>en0500001920</p> <p>Parts:</p> <ul style="list-style-type: none"> • A: Terminal cable, incoming • B: Terminal cable, outgoing  <p>NOTE!</p> <p>Make a note of the terminal to which each of the wires are connected. This will facilitate reconnecting to the same terminal.</p> |
| <p>4. Remove all the <i>attachment screws</i> M5x9 Fastite (24 pcs), except for the attachment screws on the left hand side of the <i>weld timer mounting plate</i>. (Let the cover "hang" in the loosened screws).</p> |  <p>A</p> <p>B</p> <p>C</p> <p>D</p> <p>E</p> <p>xx0500002297</p> <ul style="list-style-type: none"> • A: (Only used if a fan is fitted) Fan casing attachment screw (4 pcs) • B: (Only used if a fan is fitted!) Fan casing • C: Weld timer mounting plate • D: Attachment screw (24 pcs) • E: Rear plate |

Continues on next page

4 Repair

4.5.3. Replacement of Circuit Breaker

Continued

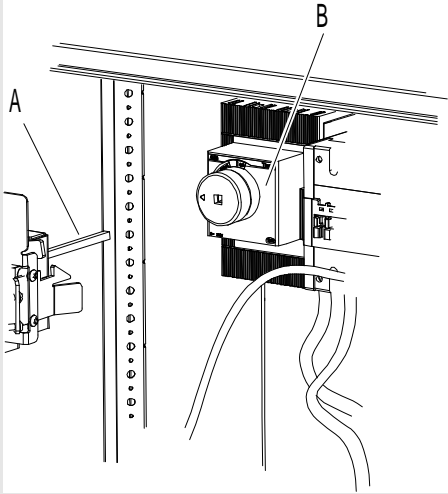
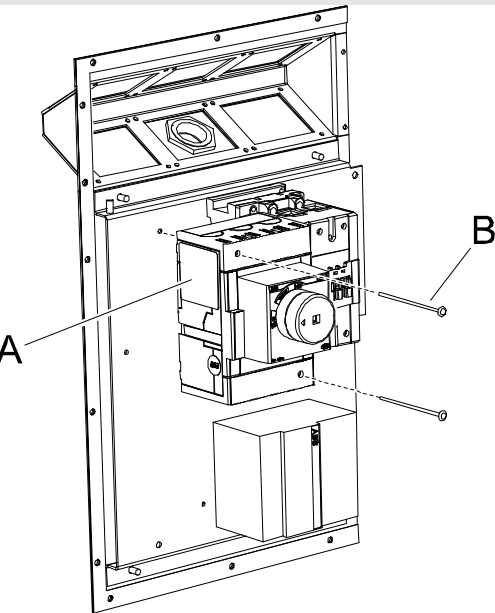
| | Action | Note |
|--|--|---|
| | 5. Pull the rear plate out 5 cm to free the extension rod from the circuit breaker. |  <p>xx0500002299</p> <ul style="list-style-type: none">• A: Extension rod• B: Circuit breaker |
| | 6. Remove the two <i>attachment screws</i> holding the <i>circuit breaker</i> and remove it. |  <p>xx0500002295</p> <ul style="list-style-type: none">• A: Circuit breaker• B: Attachment screws |

© Copyright 2006-2010 ABB. All rights reserved.

Refitting

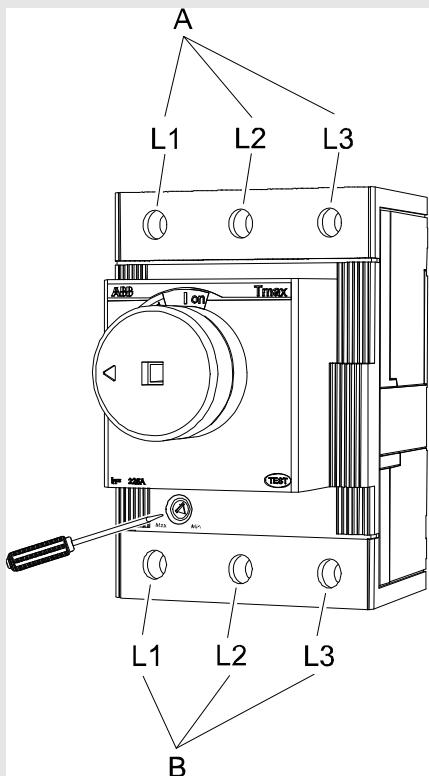
| | Action | Note |
|----|---|--|
| 1. | Refit the Circuit Breaker. | Follow the steps in section <i>Removal</i> above in reverse order. |
| 2. | <p>Check that the breaker is correctly adjusted for the weld timer mounted in the spotwelding cabinet.</p> <p>The T1 breaker is by default adjusted to 110 A (min.)</p> |  <p>xx0500002522</p> <ul style="list-style-type: none"> • A: Incoming power • B: Outgoing power |

Extension rod

The extension rod is included as a kit together with the “power on/off” switch. At delivery the extension rod is too long and has to be cut. Compare the new rod with the one to be replaced, and cut to the same length.

4 Repair

4.5.4. Replacement of door interlock

4.5.4. Replacement of door interlock

Location

The location of the door interlock is shown in the illustration below.

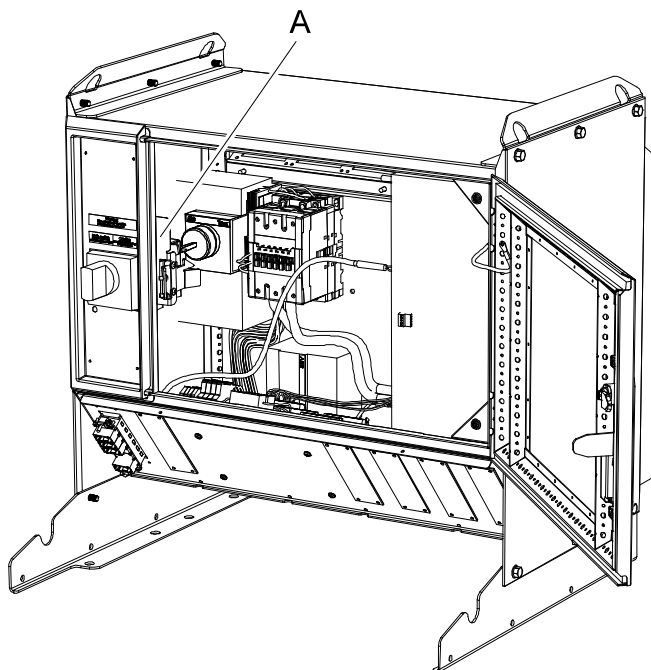

xx0500002524

| | |
|---|----------------|
| A | Door interlock |
|---|----------------|

Required equipment

| Equipment | Spare part no. | Art no. | Note |
|-------------------------------------|----------------|----------------------------------|--|
| IRC5 Door interlock rotary switch | 3HAC026071-001 | | |
| Standard toolkit DressPack/SpotPack | | 3HAC17290-7 | The contents are defined in section Toolkits, DressPack/SpotPack on page 257 . |
| Drill | | | 6 mm |
| Circuit diagram | | 3HAC026136-001 3HAC026208-001 | |

© Copyright 2006-2010 ABB. All rights reserved.

Continues on next page

Removal

The following procedures details how to remove the door interlock rotary switch.

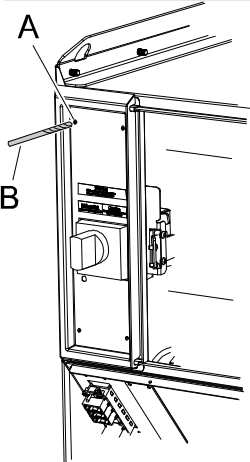
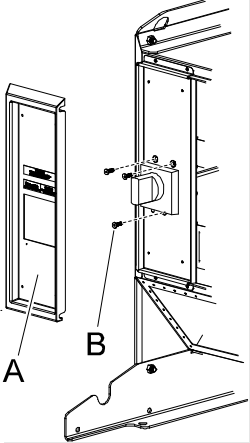
| | Action | Note |
|----|---|--|
| 1. |  <p>DANGER! Before any work inside the cabinet, please observe the safety information in the section <i>DANGER - Make sure that the main power has been switched off</i> in the Product manual for the controller cabinet IRC5.</p> | |
| 2. | Drill the head off the pop rivet. |  <p>xx0500002525</p> <ul style="list-style-type: none"> • A: Pop rivet • B: Drill, 6mm |
| 3. | Use a polygrip tongs to remove the rest of the rivet from inside of the cabinet. | |
| 4. | Remove the panel cover and door interlock attachment screws. |  <p>xx0500002526</p> <ul style="list-style-type: none"> • A: Panel cover • B: Door interlock attachment screw (3 pcs) |

4 Repair

4.5.4. Replacement of door interlock

Continued

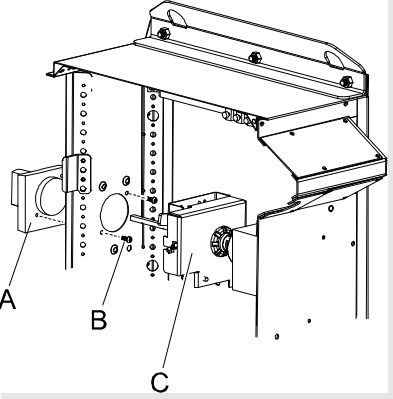
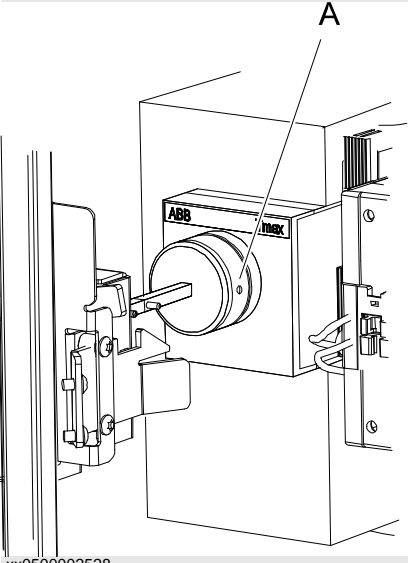
| Action | Note |
|---|--|
| 5. Slide the door interlock backwards on the extension rod. |  <p>xx0500002527</p> <ul style="list-style-type: none">• A: Rotary switch• B: Rotary switch attachment screws (2 pcs)• C: Door interlock |
| 6. Unscrew the <i>rotary switch attachment screws</i> , and remove the <i>rotary switch</i> . | |
| 7. Unscrew the extension rod locking screw to remove the extension rod. |  <p>xx0500002528</p> <ul style="list-style-type: none">• A: Locking screw |
| 8. Remove the door interlock. | |

© Copyright 2006-2010 ABB. All rights reserved.

Continues on next page

Refitting

The following procedures details how to refit the door interlock.

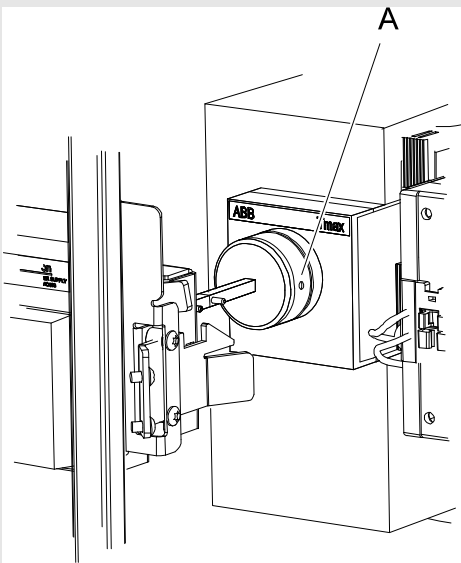
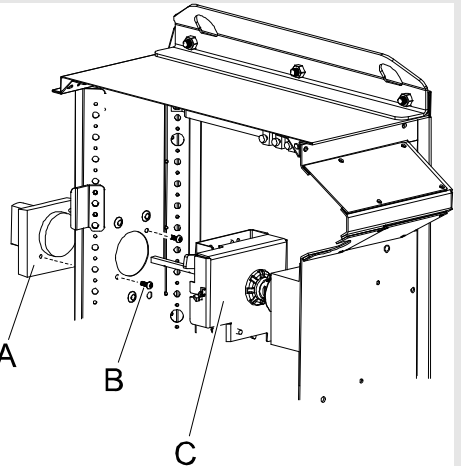
| | Action | Note |
|----|--|--|
| 1. | Refit the new door interlock on the extension rod. | |
| 2. | Refit the extension rod on the breaker and lock the locking screw. |  <p>xx0500002528</p> <ul style="list-style-type: none"> • A: Locking screw |
| 3. | Refit the rotary switch and attachment screws. |  <p>xx0500002527</p> <ul style="list-style-type: none"> • A: Rotary switch • B: Rotary switch attachment screws (2 pcs) • C: Door interlock |

4 Repair

4.5.4. Replacement of door interlock

Continued

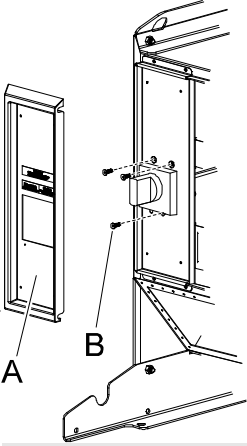
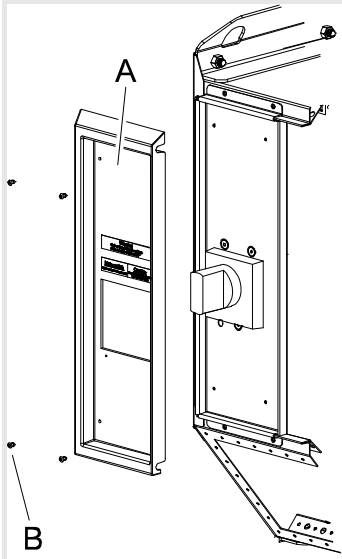
| | Action | Note |
|--|--|---|
| | 4. Refit the door interlock attachment screws. |  <p>xx0500002526</p> <ul style="list-style-type: none">• A: Panel cover• B: Door interlock attachment screws |
| | 5. Refit the panel cover with four pop rivets. |  <p>xx0500002530</p> <ul style="list-style-type: none">• A: Panel cover• B: Pop rivet (4 pcs) |

4.5.5. Replacement of contactor

Overview

This section is not applicable to SpotPack Basic.

The section below details how to replace a contactor in the Spotwelding cabinet

Location

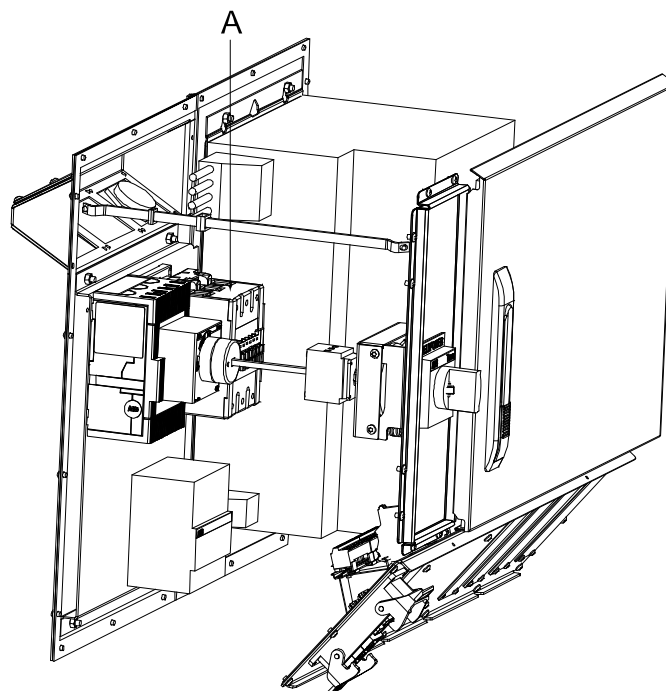

en0500001908

| | |
|---|--|
| A | Contacteur A110-30-00. (230V, 160A AC-1) |
| A | Contacteur A110-30-00. (115V, 160A AC-1) |

Required equipment

| Equipment | Spare part no. | Art. no. | Note |
|--|-----------------|----------------------------------|--|
| Contacteur | 1SFL451001R8000 | | A110-30-00 |
| Contacteur | 1SFL451001R8900 | | A110-30-00 |
| Standard toolkit DressPack/ SpotPack. | | 3HAC17290-7 | The contents are defined in section Toolkits, DressPack/ SpotPack on page 257. |
| Circuit diagram | | 3HAC026136-001 3HAC026208-001 | |



Continues on next page

4 Repair

4.5.5. Replacement of contactor

Continued

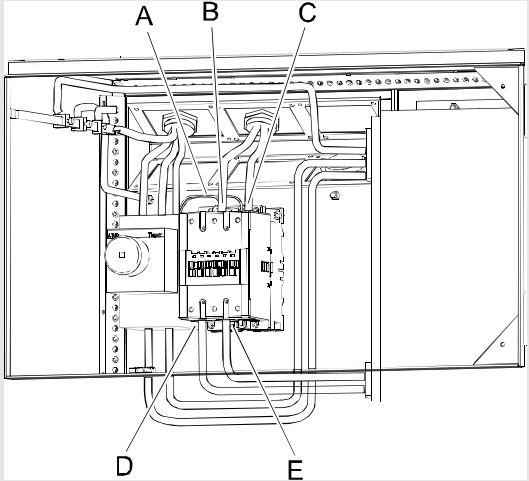
Removal

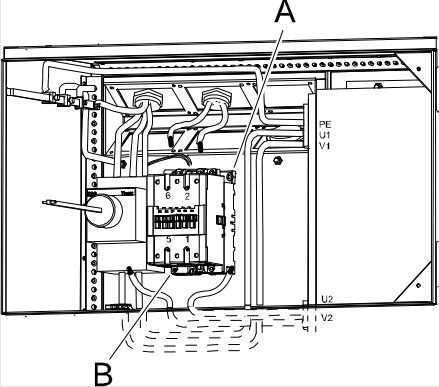
| Action | Note |
|--|---|
| 1.  DANGER! Before any work inside the cabinet, please observe the safety information in section <i>DANGER - Make sure that the main power has been switched off</i> in the Product manual for the controller cabinet. | |
| 2. Remove all cables from A to E, from the contactor. |  <p>en0500001899</p>  <p>NOTE! Make a note of the terminal to which each of the wires are connected. This will make it easier to reconnect to the same terminal.</p> |
| 3. Remove the <i>attachment screws</i> M6x16 quality 8.8-A2F (2 pcs) holding the contactor. |  <p>en0500001900</p> <ul style="list-style-type: none">• A-B: Attachment screws M6x16 (2 pcs). |
| 4. Replace the contactor. | |

© Copyright 2006-2010 ABB. All rights reserved.

Continues on next page

Refitting

| | Action | Note |
|----|----------------------|--|
| 1. | Refit the contactor. | Follow the steps in section <i>Removal</i> above in reverse order. |

4 Repair

4.5.6. Replacement of external residual current release

4.5.6. Replacement of external residual current release

Overview

This section is not applicable to SpotPack Basic.

This section details replacement of a residual current release.

Location

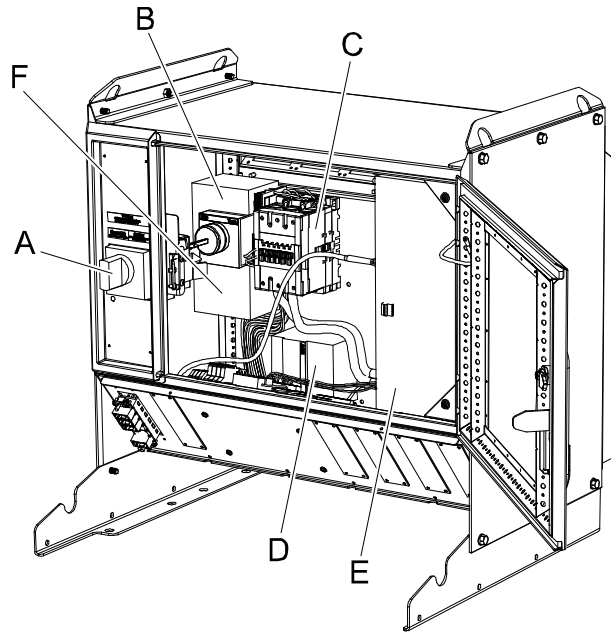

en0500002310

| | |
|---|---------------------------------|
| A | Main switch |
| B | Circuit breaker |
| C | Contactor |
| D | Residual current release (MFDC) |
| E | Weld timer |
| F | Residual current release (AC) |

Required equipment

| Equipment | Spare part no. | Art. no. | Note |
|--------------------------------------|----------------|----------------------------------|---|
| Residual current release (MFDC) | 1SDA055250R1 | | RC221/1 |
| Residual current release (AC) | 1SDA051398R1 | | |
| Standard toolkit DressPack/SpotPack. | | 3HAC17290-7 | The contents are defined in section Toolkits, DressPack/SpotPack on page 257. |
| Circuit diagram | | 3HAC026136-001 3HAC026208-001 | |

© Copyright 2006-2010 ABB. All rights reserved.

Continues on next page

Removal

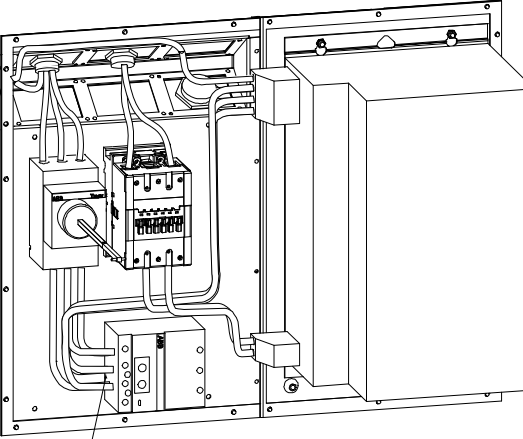
| | Action | Note |
|----|--|--|
| 1. |  <p>DANGER! Before any work inside the cabinet, please observe the safety information in the section <i>DANGER - Make sure that the main power has been switched off</i> in the Product manual for the controller cabinet IRC5</p> | |
| 2. | Remove all <i>cable harness</i> from the external residual current release. |  <p>A en0500001910</p> <ul style="list-style-type: none"> • A: Cable harness |
| 3. | Disconnect the earth cable. | |

4 Repair

4.5.6. Replacement of external residual current release

Continued

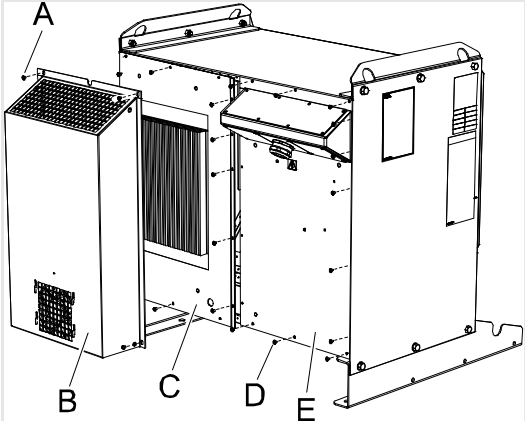
| | Action | Note |
|--|---|---|
| | 4. Remove all the <i>attachment screws</i> , except for the attachment screws on the left hand side of the weld timer mounting plate. Let the cover "hang" on screws mounted on the left side of the weld timer mounting plate. |  <p>xx0500002297</p> <ul style="list-style-type: none">• A: (Only used if a fan is fitted!) Attachment screws, fan casing (4 pcs)• B: (Only used if a fan is fitted) Fan casing• C: Weld timer mounting plate• D: Attachment screws (24 pcs)• E: Rear plate |
| | 5. Remove the two <i>attachment screws</i> on the <i>residual current release</i> and replace the unit. | |

Refitting

| | Action | Note |
|----|-------------------------------------|--|
| 1. | Refit the residual current release. | Follow the steps in section <i>Removal</i> above in reverse order. |

4.6 Tipdresser

4.6.1. Replacement of Tipdresser parts

Overview

This section details how to replace the tipdresser parts (motor starter, auxiliary switches and motor contactor) in the spotwelding cabinet.

Location

Parts described in the procedure are located as shown in the illustration below.

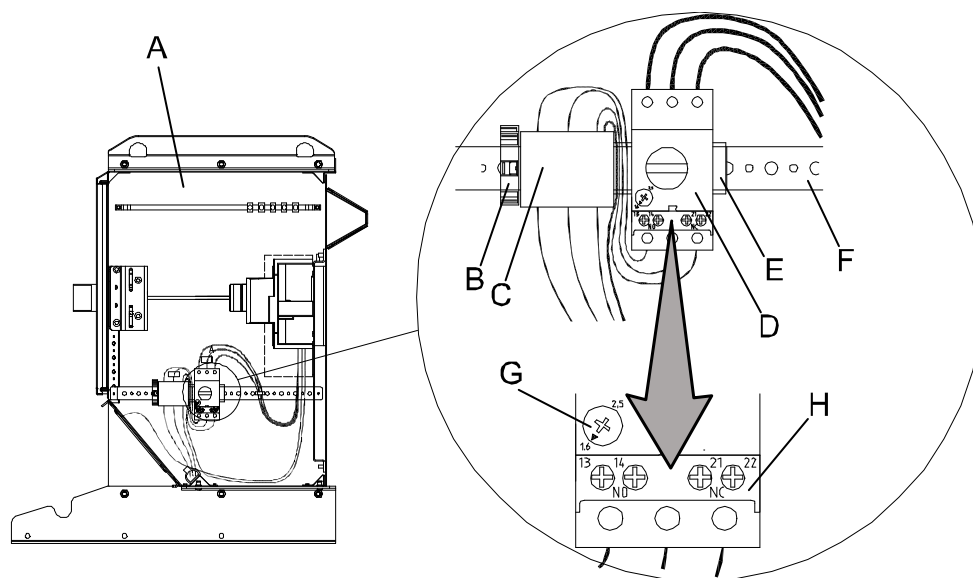

xx0600003247

| | |
|---|--|
| A | Spotwelding cabinet |
| B | End clamp |
| C | Motor contactor |
| D | Motor starter |
| E | Terminal rail |
| F | Mounting bracket |
| G | Screw choosing either 1.6 A or 2.5 A (NOTE! Set on 1.6 A on delivery!) |
| H | Auxiliary switches |

4 Repair

4.6.1. Replacement of Tippedresser parts

Continued

Replacement of motor starter, auxiliary switches and/or motor contactor

The procedure below details how to replace the motor starter, auxiliary switches and motor contactor.

| | Action | Note |
|----|--|---|
| 1. |  DANGER! Before any work inside the cabinet, please observe the safety information in section <i>DANGER - Make sure that the main power has been switched off</i> in the Product manual for the controller IRC5. | |
| 2. | The <i>motor starter</i> and <i>motor contactor</i> are snap locked on the <i>terminal rail</i> . | Shown in the figure in section Location on page 245 . |
| 3. | The <i>auxiliary switches</i> are snap locked on the <i>motor starter</i> . | Shown in the figure in section Location on page 245 . |
| 4. | Release the snap locks when removing. | |
| 5. | Snap on the parts in their respective places, when fitting. | |
| 6. | Make sure that the snap locks are locked. | |

5 Decommissioning

5.1. Environmental information

Hazardous material

The table specifies some of the materials in the robot and their respective use throughout the product.

Dispose components properly in order to prevent health or environmental hazards.

| Material | Example application |
|-----------------------------|---|
| Batteries, NiCad or Lithium | Serial measurement board |
| Copper | Cables, motors |
| Cast iron/nodular iron | Base, lower arm, upper arm |
| Steel | Gears, screws, base-frame, and so on. |
| Neodymium | Brakes, motors |
| Plastic/rubber (PVC) | Cables, connectors, drive belts, and so on. |
| Aluminium | Covers, sync. brackets |

5 Decommissioning

5.1. Environmental information

6 Reference information

6.1. Introduction

General

This chapter includes general information, complementing the more specific information in the different procedures in the manual.

6 Reference information

6.2. Applicable safety standards

6.2. Applicable safety standards

Standards, EN ISO

The manipulator system is designed in accordance with the requirements of:

| Standard | Description |
|---------------------------------|--|
| EN ISO 12100 -1 | Safety of machinery - Basic concepts, general principles for design - Part 1: Basic terminology, methodology |
| EN ISO 12100 -2 | Safety of machinery - Basic concepts, general principles for design - Part 2: Technical principles |
| EN ISO 13849-1 | Safety of machinery, safety related parts of control systems - Part 1: General principles for design |
| EN ISO 13850 | Safety of machinery - Emergency stop - Principles for design |
| EN ISO 10218-1 ¹ | Robots for industrial environments - Safety requirements -Part 1 Robot |
| EN ISO 9787 | Manipulating industrial robots, Coordinate systems and motion nomenclatures |
| EN ISO 9283 | Manipulating industrial robots, Performance criteria and related test methods |
| EN ISO 14644-1 ² | Classification of air cleanliness |
| EN ISO 13732-1 | Ergonomics of the thermal environment - Part 1 |
| EN IEC 61000-6-4 (option 129-1) | EMC, Generic emission |
| EN IEC 61000-6-2 | EMC, Generic immunity |
| EN IEC 60974-1 ³ | Arc welding equipment - Part 1: Welding power sources |
| EN IEC 60974-10 ³ | Arc welding equipment - Part 10: EMC requirements |
| EN IEC 60204-1 | Safety of machinery - Electrical equipment of machines - Part 1 General requirements |
| IEC 60529 | Degrees of protection provided by enclosures (IP code) |

1. There is a deviation from paragraph 6.2 in that only worst case stop distances and stop times are documented.

2. Only robots with Protection Clean Room.

3. Only valid for arc welding robots. Replaces EN IEC 61000-6-4 for arc welding robots.

European standards

| Standard | Description |
|----------|--|
| EN 614-1 | Safety of machinery - Ergonomic design principles - Part 1: Terminology and general principles |
| EN 574 | Safety of machinery - Two-hand control devices - Functional aspects - Principles for design |
| EN 953 | Safety of machinery - General requirements for the design and construction of fixed and movable guards |

Continued

Other standards

| Standard | Description |
|------------------------------------|---|
| ANSI/RIA R15.06 | Safety Requirements for Industrial Robots and Robot Systems |
| ANSI/UL 1740 (option 429-1) | Safety Standard for Robots and Robotic Equipment |
| CAN/CSA Z 434-03 (option 429-1) | Industrial Robots and Robot Systems - General Safety Requirements |

6 Reference information

6.3. Unit conversion

6.3. Unit conversion

Converter table

Use the table below to convert units used in this manual.

| Quantity | Units | | |
|----------|-------|--------------|----------|
| Length | 1 m | 3.28 ft | 39.37 in |
| Weight | 1 kg | 2.21 lb | |
| Pressure | 1 bar | 100 kPa | 14.5 psi |
| Force | 1 N | 0.738 lbf | |
| Moment | 1 Nm | 0.738 lbf-tn | |
| Volume | 1 L | 0.264 US gal | |

6.4. Screw joints

General

This section details how to tighten the various types of screw joints on the robot.

The instructions and torque values are valid for screw joints comprised of metallic materials and do *not* apply to soft or brittle materials.

UNBRAKO screws

UNBRAKO is a special type of screw recommended by ABB for certain screw joints. It features special surface treatment (Gleitmo as described below) and is extremely resistant to fatigue.

Whenever used, this is specified in the instructions, and in such cases, *no other type of replacement screw* is allowed. Using other types of screws will void any warranty and may potentially cause serious damage or injury.

Gleitmo treated screws

Gleitmo is a special surface treatment to reduce the friction when tightening the screw joint. Screws treated with Gleitmo may be reused 3-4 times before the coating disappears. After this the screw must be discarded and replaced with a new one.

When handling screws treated with Gleitmo, protective gloves of **nitrile rubber** type should be used.

Screws lubricated in other ways

Screws lubricated with Molycote 1000 should *only* be used when specified in the repair, maintenance or installation procedure descriptions.

In such cases, proceed as follows:

1. Apply lubricant to the screw thread.
2. Apply lubricant between the plain washer and screw head.
3. Screw dimensions of M8 or larger must be tightened with a torque wrench. Screw dimensions of M6 or smaller may be tightened without a torque wrench *if* this is done by trained and qualified personnel..

| Lubricant | Art. no. |
|--|--------------|
| Molycote 1000 (molybdenum disulphide grease) | 11712016-618 |

Continues on next page

6 Reference information

6.4. Screw joints

Continued

Tightening torque

Before tightening any screw, note the following:

- Determine whether a **standard** tightening torque or **special** torque is to be applied. The **standard torques** are specified in the tables below. Any **special torques** are specified in the Repair, Maintenance or Installation procedure descriptions. **Any special torque specified overrides the standard torque!**
- Use the *correct tightening torque* for each type of screw joint.
- Only use *correctly calibrated* torque keys.
- Always *tighten the joint by hand*, and never use pneumatic tools.
- Use the *correct tightening technique*, that is *do not* jerk. Tighten the screw in a slow, flowing motion.
- Maximum allowed total deviation from the specified value is **10%**!

The table below specifies the recommended standard tightening torque for *oil-lubricated screws with slotted or cross-recess head screws*.

| Dimension | Tightening torque (Nm) Class 4.8, oil-lubricated |
|-----------|---|
| M2.5 | 0.25 |
| M3 | 0.5 |
| M4 | 1.2 |
| M5 | 2.5 |
| M6 | 5.0 |

The table below specifies the recommended standard tightening torque for *oil-lubricated screws with Allen head screws*.

| Dimension | Tightening torque (Nm) Class 8.8, oil-lubricated | Tightening torque (Nm) Class 10.9, oil-lubricated | Tightening torque (Nm) Class 12.9, oil-lubricated |
|-----------|---|--|--|
| M5 | 6 | - | - |
| M6 | 10 | - | - |
| M8 | 24 | 34 | 40 |
| M10 | 47 | 67 | 80 |
| M12 | 82 | 115 | 140 |
| M16 | 200 | 290 | 340 |
| M20 | | | 550 |
| M24 | 725 | 960 | 1150 |

© Copyright 2006-2010 ABB. All rights reserved.

Continues on next page

Continued

The table below specifies the recommended standard tightening torque for *Molycote-lubricated screws* with *Allen head screws*.

| Dimension | Tightening torque (Nm) Class 10.9, Molycote-lubricated | Tightening torque (Nm) Class 12.9, Molycote-lubricated |
|------------------|---|---|
| M8 | 28 | 35 |
| M10 | 55 | 70 |
| M12 | 96 | 120 |
| M16 | 235 | 280 |
| M20 | | 550 |
| M24 | 790 | 950 |

The table below specifies the recommended standard tightening torque for *water and air connectors* when *one* or *both* connectors are made of *brass*.

| Dimension | Tightening torque Nm - Nominal | Tightening torque Nm - Min. | Tightening torque Nm - Max. |
|------------------|---|--|--|
| 1/8 | 12 | 8 | 15 |
| 1/4 | 15 | 10 | 20 |
| 3/8 | 20 | 15 | 25 |
| 1/2 | 40 | 30 | 50 |
| 3/4 | 70 | 55 | 90 |

6 Reference information

6.5. Weight specifications

6.5. Weight specifications

Definition

In installation, repair and maintenance procedures, weights of the components handled are sometimes specified. All components exceeding 22 kg (50 lbs) are highlighted in this way. To avoid injury, ABB recommends the use of lifting equipment when handling components with a weight exceeding 22 kg. A wide range of lifting tools and devices are available for each manipulator model.

Example

Below is an example of how a weight specification is presented, inside a procedure table:

| | Action | Note |
|--|---|------|
| |  CAUTION! The motor weighs 32 kg! All lifting equipment used must be sized accordingly! | |

6.6. Toolkits, DressPack/SpotPack

General

All service (repair, maintenance and installation) instructions contain lists of tools required to perform the specified activity. All special tools, that is all tools that are not considered standard as defined below, are listed in their instructions respectively.

This way, the tools required are the sum of the Standard Toolkit and any tools listed in the instruction.

Standard toolkit

This standard toolkit contains a set of standard tools used for DressPack/SpotPack, 3HAC17290-7.

| Qty | Art. no. | Tool | Note |
|-----|----------|-------------------------------|--|
| 1 | - | Socket head cap, 5-17mm | - |
| 1 | - | Torx socket no: 20-60 | - |
| 1 | - | Phillips screwdriver, small | For Harting connectors |
| 1 | - | Flat screwdriver, medium | For Harting connectors |
| 2 | - | Ring-open-end spanner 8-19 mm | For water connectors on water and air unit |
| 1 | - | Open end wrench, 27 mm. | For Tension arm unit and water connectors on DressPack |
| 1 | - | Open end wrench, 36 mm | For water connectors on DressPack |

Toolkit, water panel

This toolkit contains tools needed for water panel:

| Qty | Art.no. | Tool | Note |
|-----|---------|------------------------------|-----------------|
| 1 | - | Socket head cap 4 mm | For water panel |
| 2 | - | Ring-open-end spanner, 36 mm | For water panel |

Toolkit, cables

This toolkit contains tools needed for work with cables:

| Qty | Art.no | Tool | Note |
|-----|-----------------------------------|---|-----------------------|
| 1 | 0999 000 0171 (D-sub) | Removal and Insertion tool for pins and sockets | Art. no. from Harting |
| 1 | 0999 000 0012 (HAN DD) | Removal tool for pins and sockets | Art. no. from Harting |
| 1 | 0999 000 0319 (HAN EE) | Removal tool for pins and sockets | Art. no. from Harting |
| 1 | 0999 000 0059 (HAN DD and HAN EE) | Insertion tool for pins and sockets | Art. no. from Harting |
| 1 | - | Stripping pliers | |
| 1 | 09 99 000 0021 | Crimping tool HARTING with locator | Art. no. from Harting |

Continues on next page

6 Reference information

6.6. Toolkits, DressPack/SpotPack

Continued

| Qty | Art.no | Tool | Note |
|-----|----------------------------------|---------------------------------|-----------------------|
| 1 | 09 99 000 0001 | Crimping tool BUCHANAN, HARTING | Art. no. from Harting |
| 1 | 09 99 000 0175 09 99 000 0169 | Crimping tool HARTING | Art. no. from Harting |

6.7. Lifting equipment and lifting instructions

General

Many repair and maintenance activities require different pieces of lifting equipment, which are specified in each procedure.

The use of each piece of lifting equipment is *not* detailed in the activity procedure, but in the instruction delivered with each piece of lifting equipment.

This implies that the instructions delivered with the lifting equipment should be stored for later reference.

6 Reference information

6.7. Lifting equipment and lifting instructions

7 Spare parts

7.1. Introduction

General

This chapter contains more specific article information. It is to be regarded as a complement to the slightly generic procedure information found in the Installation, Maintenance and Repair chapters.

7 Spare parts

7.2.1. DressPack for - IRBDP MH 2 CE and IRBDP SW 2 CE

7.2 DressPack IRB 6620

7.2.1. DressPack for - IRBDP MH 2 CE and IRBDP SW 2 CE

General

The following section details spare parts for cable packages IRBDP MH 2 CE and IRBDP SW 2 CE.

Lower/Upper arm cable package

Article number: 3HAC024640-001, 3HAC024641-001

| Part | Article number | Note |
|---|----------------|-----------------------------|
| Process Cable Package SW, CPS/Ethernet + SP 3 hoses | 3HAC024649-001 | Paracom Paracom+Ethernet |
| Process Cable Package SW, CPS/CBus + SP 3 hoses | 3HAC024651-001 | Parabuscom |
| Process Cable Package SW, CPS/Ethernet + SP 3 hoses | 3HAC038557-001 | Paracom Ethernet |
| Process Cable Package MH CPS/Ethernet, 1 hose | 3HAC024654-001 | Paracom Paracom+Ethernet |
| Process Cable Package MH CPS/CBus 1 hose | 3HAC024655-001 | Parabuscom |
| Process Cable Package MH CPS/Ethernet, 1 hose | 3HAC034141-001 | Paracom Ethernet |
| Material Set Lower ArmMH | 3HAC024656-001 | |
| Material Set lower ArmSW | 3HAC024652-001 | |
| Material Set upper arm | 3HAC024653-001 | |

Spare parts for cable package

| Qty | Spare part | Article number | Note |
|-----|------------------------------------|----------------|--------------------|
| | Protection hose | 3HAC5320-2 | Wear part 2.5 m |
| | Reinforced protection hose | 3HAC5320-5 | Wear part 2 m |
| | Protective sleeve | 3HAC021580-001 | Wear part |
| | Hose reinforcement | 3HAC022194-001 | Wear part |
| | Hose reinforce protection (UL, UR) | 3HAC17221-1 | |
| 4 | Slide sleeve | 3HAC16208-1 | Wear part |
| 2 | Hose clamp Diam = 79-87 | 3HAC5325-3 | |
| 4 | Hose clamp Diam = 94-102 | 3HAC5325-2 | |
| | Clamp jaw | 3HAC14590-1 | |
| | End jaw | 3HAC14512-1 | |
| | Middle jaw | 3HAC14290-1 | |
| | Swivel | 3HAC027389-001 | |
| | Strap, velcro | 3HAC12625-1 | |

© Copyright 2006-2010 ABB. All rights reserved.

Continues on next page

Continued

| Qty | Spare part | Article number | Note |
|-----|-----------------------|----------------|------|
| | Hose support | 3HAC024102-090 | |
| | Bracket, hose support | 3HAC024102-049 | |
| | Gripping clamp | 3HAC14280-1 | |

7 Spare parts

7.2.2. DressPack cable package lower arm - IRBDP MH 3 LE

7.2.2. DressPack cable package lower arm - IRBDP MH 3 LE

Overview

The following section details spare parts for DressPack upper arm cable package IRBDP MH 3 LE.

DressPack cable package lower arm - IRBDP MH 3 LE

Article number: 3HAC029595-001

| Parts | Article no. | Note |
|------------------------------|----------------|---------------------|
| Process cable package 1-3 MH | 3HAC029704-001 | Paracom |
| Process cable package 1-3 MH | 3HAC029705-001 | Parabuscom |
| Process cable package 1-3 MH | 3HAC034140-001 | Paracom Ethernet |
| Material set lower arm MH | 3HAC029710-001 | |

Spare parts for cable package

| Parts | Article no. | Note |
|-----------------|----------------|--|
| Protection hose | 3HAC024692-052 | Wear part 2.2 m Only sold in whole meters! |
| Clamp half | 3HAC024692-051 | 2 pcs needed |
| Gripping clamp | 3HAC024692-013 | |
| Rubber clamp | 3HAC11487-6 | |
| Strap, velcro | 3HAC12625-1 | |

7.2.3. DressPack cable package upper arm - IRBDP MH 3 UE

Overview

The following section details spare parts for DressPack upper arm cable package IRBDP MH 3 UE.

DressPack cable package upper arm - IRBDP MH 3 UE

Article number: 3HAC029596-001

| Parts | Article no. | Note |
|--------------------------------------|----------------|------------------------|
| Process cable package upper arm MH 3 | 3HAC026813-001 | Paracom CPS |
| Process cable package upper arm MH 3 | 3HAC034204-002 | Ethernet |
| Process cable package upper arm MH 3 | 3HAC026813-002 | Parabuscom CPS/CBUS |
| Material set upper arm MH 3 | 3HAC029770-001 | |

Spare parts for cable package

| Parts | Article no. | Note |
|--------------------------|----------------|--------------------|
| Protection hose | 3HAC024692-060 | Wear part 1.4 m |
| Hose upper arm MH 3 | 3HAC024692-047 | |
| Clamp half | 3HAC024692-051 | 2 pcs needed |
| Gripping clamp | 3HAC024692-013 | |
| Rubber clamp | 3HAC11487-8 | |
| Strap, velcro | 3HAC12625-1 | |
| Protective sleeve, NW 52 | 3HAC032661-001 | Wear part |

7 Spare parts

7.2.4. SpotPack Basic cable package - IRBDP SW 5 CE

7.2.4. SpotPack Basic cable package - IRBDP SW 5 CE

Overview

The following section details spare parts for SpotPack Basic cable package IRBDP SW 5 CE.

SpotPack Basic cable package - IRBDP SW 5 CE

| Parts | Article no. | Note |
|--|----------------|--------|
| Process cable package lower/upper arm SW | 3HAC031151-002 | CPS |
| Process cable package lower/upper arm SW | 3HAC031153-002 | CPS+SP |
| Material set lower arm SW | 3HAC029500-002 | |
| Material set upper arm SW | 3HAC029506-002 | |

Wear parts of cable package

| Parts | Article no. | Note |
|--------------------|----------------|-----------|
| Protection hose | 3HAC5320-2 | Wear part |
| Hose reinforcement | 3HAC022194-001 | Wear part |
| Protective sleeve | 3HAC021580-001 | Wear part |

Spare parts for cable package

| Parts | Spare part no. | Note |
|-------------------------------|----------------|------|
| CS cable, axes 2-6 | 3HAC029391-005 | |
| Weld cable 25 mm ² | 3HAC029392-004 | |
| Servo Power, axes 2-6 | 3HAC029580-004 | |
| Resolvercable,R2.FB7 | 3HAC030638-004 | |
| Hose blue | 3HAC031152-001 | |
| Hose green | 3HAC031152-002 | |
| Hose red | 3HAC031152-003 | |
| Hose black | 3HAC031152-004 | |
| Hose protection | 3HAC031582-002 | |
| Hose protection | 3HAC031582-003 | |
| Swivel complete | 3HAC027389-001 | |
| Hose clamp Diam=79-87 | 3HAC5325-3 | |
| Slide sleeve | 3HAC16208-1 | |
| Hose clamp Diam=94-102 | 3HAC5325-2 | |
| Hose & cable retainer 60 | 3HAC026156-003 | |
| Hose & cable retainer | 3HAC14811-1 | |
| Plastic clamp | 3HAC026549-005 | |
| Strap, velcro | 3HAC12625-1 | |
| Strap | 3HAC024008-001 | |
| Gripping clamp | 3HAC14280-1 | |
| End jaw | 3HAC14512-1 | |
| Ball joint housing | 3HAC021601-001 | |

Continues on next page

Continued

| Parts | Spare part no. | Note |
|------------------------------|----------------|------|
| Process cable support axis 6 | 3HAC025495-001 | |

7 Spare parts

7.2.5. Connection kits

7.2.5. Connection kits

General

This chapter contains more specific article information. It is to be regarded as a complement to the slightly generic procedure information found in the Installation, Maintenance and Repair chapters.

The robot itself and controller cabinet, is detailed in separate technical documents.

Spare parts

| Spare part | Article number | Note |
|--|----------------|---------------|
| CP/CS, Proc. 1 on base | 3HAC16667-1 | |
| Weld, Proc. 1-4 on base | 3HAC17201-1 | |
| Weld, Proc. 1-4 ax.6 (35 mm ²) | 3HAC023072-001 | |
| 7-axis on base | 3HAC023441-001 | |
| CP/CS/CBUS, Proc. 1 ax. 6 | 3HAC020155-001 | Tool side |
| CP/CS/CBUS, Proc. 1 ax. 6 | 3HAC029072-001 | Tool side MH3 |

7.2.6. 7:th axis to base

General

This chapter contains more specific article information. It is to be regarded as a complement to the slightly generic procedure information found in the Installation, Maintenance and Repair chapters.

The robot itself and controller cabinet, is detailed in separate technical documents.

Spare parts

| Part | Article number | Note |
|-------------------------|----------------|------|
| 7:th axis, serial cable | 3HAC026414-001 | |
| Material set 7:th axis | 3HAC026558-002 | |

7 Spare parts

7.2.7. Customer signal/power

7.2.7. Customer signal/power

General

This chapter contains more specific article information. It is to be regarded as a complement to the slightly generic procedure information found in the Installation, Maintenance and Repair chapters.

The robot itself, consisting of robot and controller cabinet, is detailed in its own technical documents.

Spare parts floor harness (3HAC023120-001,3HAC023121-001)

| Part | Article number | Note |
|------------------------------|----------------|--------------------|
| Harness-CP/CS/DeviceNet, 7m | 3HAC022978-001 | Parallel DeviceNet |
| Harness-CS floor cable, 7m | 3HAC029393-001 | Parallel |
| Harness-CP floor cable, 7m | 3HAC029396-002 | 24V |
| Harness-CP/CS/DeviceNet, 15m | 3HAC022978-002 | Parallel DeviceNet |
| Harness-CS floor cable, 15m | 3HAC029393-002 | Parallel |
| Harness-CP floor cable, 15m | 3HAC029396-001 | 24V |
| Harness-CP/CS/DeviceNet, 22m | 3HAC022978-006 | Parallel DeviceNet |
| Harness-CP/CS/DeviceNet, 30m | 3HAC022978-003 | Parallel DeviceNet |
| Harness-CP/CS/InterBus, 7m | 3HAC023024-001 | InterBus |
| Harness-CP/CS/InterBus, 15m | 3HAC023024-002 | InterBus |
| Harness-CP/CS/InterBus, 22m | 3HAC023024-006 | InterBus |
| Harness-CP/CS/InterBus, 30m | 3HAC023024-003 | InterBus |
| Harness-CP/CS/Pbus, 7m | 3HAC022988-001 | ProfiBus |
| Harness-CP/CS/Pbus, 15m | 3HAC022988-002 | ProfiBus |
| Harness-CP/CS/Pbus, 22m | 3HAC022988-006 | ProfiBus |
| Harness-CP/CS/Pbus, 30m | 3HAC022988-003 | ProfiBus |
| Harness-CP/CS, 7m | 3HAC022957-001 | Parallel |
| Harness-CP/CS, 15m | 3HAC022957-002 | Parallel |
| Harness-CP/CS, 22m | 3HAC022957-006 | Parallel |
| Harness-CP/CS, 30m | 3HAC022957-003 | Parallel |

7.2.8. DressPack - Water and air unit

Overview

The following section details spare parts for DressPack Water and air unit.

Water and air unit

| Qty | Parts | Article no. | Note |
|-----|--------------------|----------------|-------------------|
| 1 | Water and air unit | 3HAC027294-001 | Basic Type S |
| 1 | Water and air unit | 3HAC027294-002 | 2:nd water return |
| 1 | Water and air unit | 3HAC027294-003 | E/P valve Type S |
| 1 | Water and air unit | 3HAC027294-004 | Basic Type Sb |
| 1 | Water and air unit | 3HAC027294-005 | E/P valve Type Sb |
| 1 | Connection box | 3HAC029604-001 | Type Sb |

Spare parts for Water and air unit

| Qty | Parts | Article no. | Note |
|-----|------------------------|----------------|--------------------------|
| 1 | Air supply circuit | 3HAC026657-002 | Type S |
| 1 | Air supply circuit | 3HAC026657-019 | Type Sb (SpotPack Basic) |
| 1 | Air supply circuit, EP | 3HAC026657-003 | Type S |
| 1 | Air supply circuit, EP | 3HAC026657-020 | Type Sb (SpotPack Basic) |
| 1 | Water in circuit | 3HAC026657-004 | |
| 1 | Water return circuit | 3HAC026657-005 | Type S |
| 1 | Water return circuit | 3HAC026657-021 | Type Sb (SpotPack Basic) |
| 1 | Water Y connection | 3HAC026657-006 | Type S |
| 1 | Split box | 3HAC026657-007 | Type S |

Hoses for Water and air unit

| Qty | Parts | Article no. | Note |
|-----|-------------------------|-------------|---|
| 3 | Hose water and air unit | 3HAC16845-2 | EP valve |
| 1 | Hose water and air unit | 3HAC16845-1 | (Only applicable to type S) Second water return |
| 1 | Hose water and air unit | 3HAC16845-2 | |

Cable grommets for Connection box, type Sb

| Qty | Parts | Article no. | Note |
|-----|---------------|----------------|------|
| 1 | Cable grommet | 3HAC029637-008 | |
| 1 | Cable grommet | 3HAC029637-009 | |

7 Spare parts

7.3.1. Spotwelding Cabinet IRC 5, 3HAC025036-001

7.3 Spotwelding cabinet

7.3.1. Spotwelding Cabinet IRC 5, 3HAC025036-001

Overview

The Spare Part list for the spotwelding cabinet IRC5 is divided in sections containing:

- Cabinet
- Mains
- Weld Timer
- Harness connector plate
- Accessories
- Supplementary set
- Assembly set I/O SWC
- Accessories control system

Cabinet

3HAC 025037-001

| Item no. | Description | Spare part no. | Qty | Note |
|----------|----------------------|----------------|-----|----------------|
| 1 | Cabinet | | | |
| 1.5 | Door | 3HAC025018-001 | 1 | |
| 1.5.3 | Swinghandle with cam | 3HAC020932-097 | 1 | |
| 1.6 | Hinge | 3HAC024742-001 | 2 | |
| 1.15 | Door bracket | 3HAC024708-001 | 1 | |
| 1.13 | Door bracket | 3HAC024701-012 | 1 | Door interlock |
| 1.14 | Securing plate | 3HAC024675-027 | 1 | Door interlock |

Cabinet Illustration (figure shows Type S)

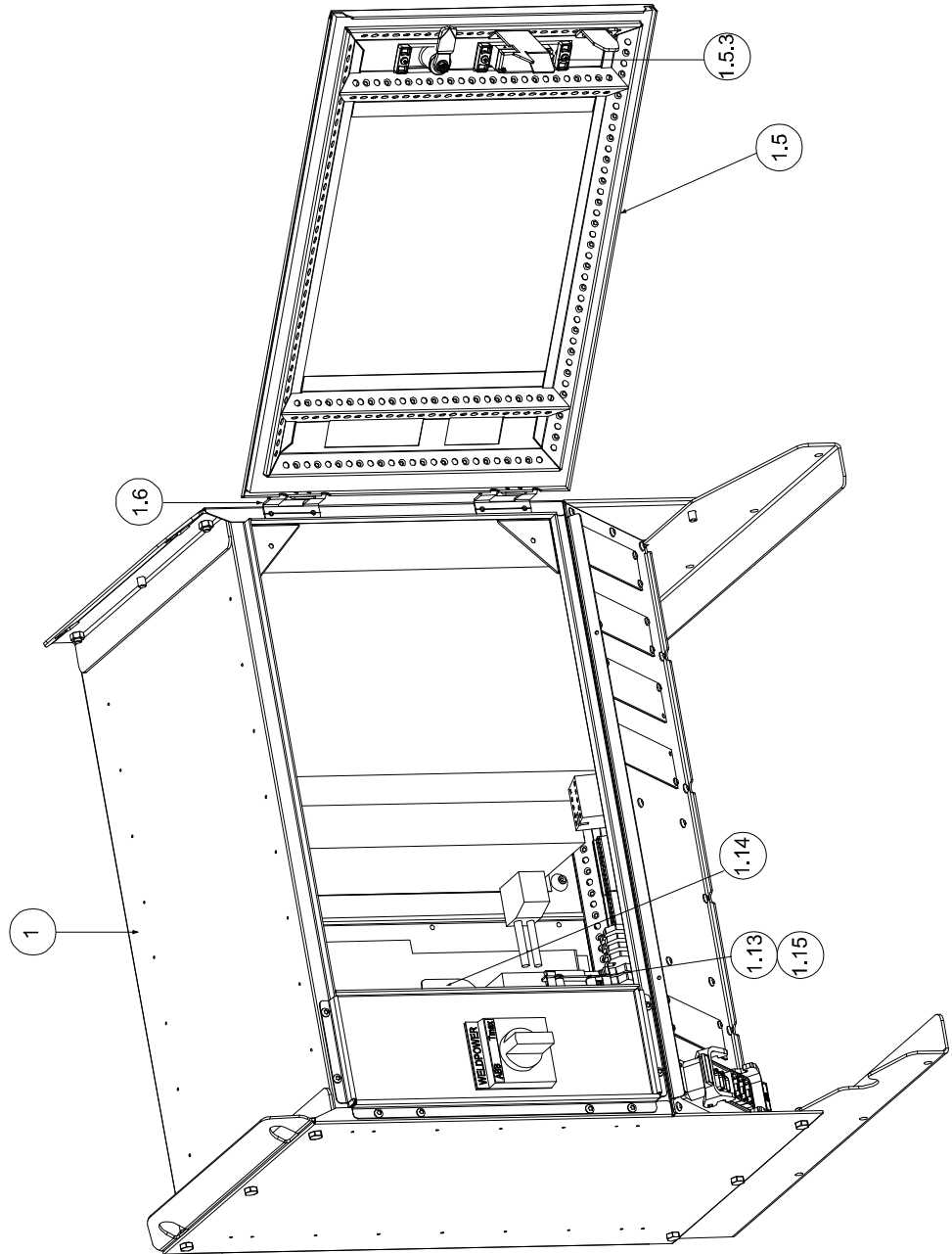

© Copyright 2006-2010 ABB. All rights reserved.

en0500001892

7 Spare parts

7.3.1. Spotwelding Cabinet IRC 5, 3HAC025036-001

Continued

Mains

3HAC 025069-001

| Item no. | Description | Spare part no. | Qty | Note |
|----------|--------------------------|-----------------|-----|--|
| | Mains | | | |
| 2.3 | Circuit breaker | 1SDA050924R1 | 1 | T1N 160 F FC CU R160 Type S and Type Sb |
| 2.3 | Circuit breaker | 1SDA053563R1 | 1 | T3N 225 UL/CSA |
| 2.3 | Circuit breaker | 1SDA055172R1 | 1 | T2H 100 UL/CSA |
| 2.4 | Residual current release | 1SDA055250R1 | 1 | RC212/1 0,05-5 KHZ T1 |
| 2.4 | Residual current release | 1SDA051398R1 | 3 | RC221/1 T1 |
| 2.5 | Contacto | 1SFL451001R8000 | 1 | A110-30-00 |
| 2.5 | Contacto | 1SFL451001R8900 | 1 | A110-30-00 |
| 2.6 | Shunt trip | 1SDA051333R1 | 1 | SOR 24V DC |
| 2.6 | Shunt trip | 1SDA053681R1 | 1 | 110-127 VAC 110-125 VDC |
| 2.7 | Auxillary contacts | 1SDA051368R1 | 1 | |
| 2.8 | Door handle incl.axis | 1SDA051383R1 | 1 | RHE Type S and Type Sb |
| 2.9 | Contact safety device | 1SDA051421R1 | 1 | T1 breaker Type S and Type Sb |
| 2.9 | Contact safety device | 1SDA051423R1 | 1 | T2 breaker |
| 2.9 | Contact safety device | 1SDA051425R1 | 1 | T3 breaker |
| 2.11 | Cable clamp | 1SDA051480R1 | 1 | T3 breaker |
| 2.11 | Cable clamp | 1SDA051452R1 | 1 | T2 breaker |
| 2.13 | Auxiliary contact | 1SBN010010R1010 | 1 | CA5-10 |
| 2.13 | Auxiliary contact | 1SBN010010R1001 | 1 | CA5-01 |
| 2.15 | Surge suppressor | 1SBN050200R1002 | 1 | RC5-2/250 |
| 2.16 | Harness power panel | 3HAC025114-001 | 1 | |

© Copyright 2006-2010 ABB. All rights reserved.

Continues on next page

Mains Illustration (figure shows Type S)

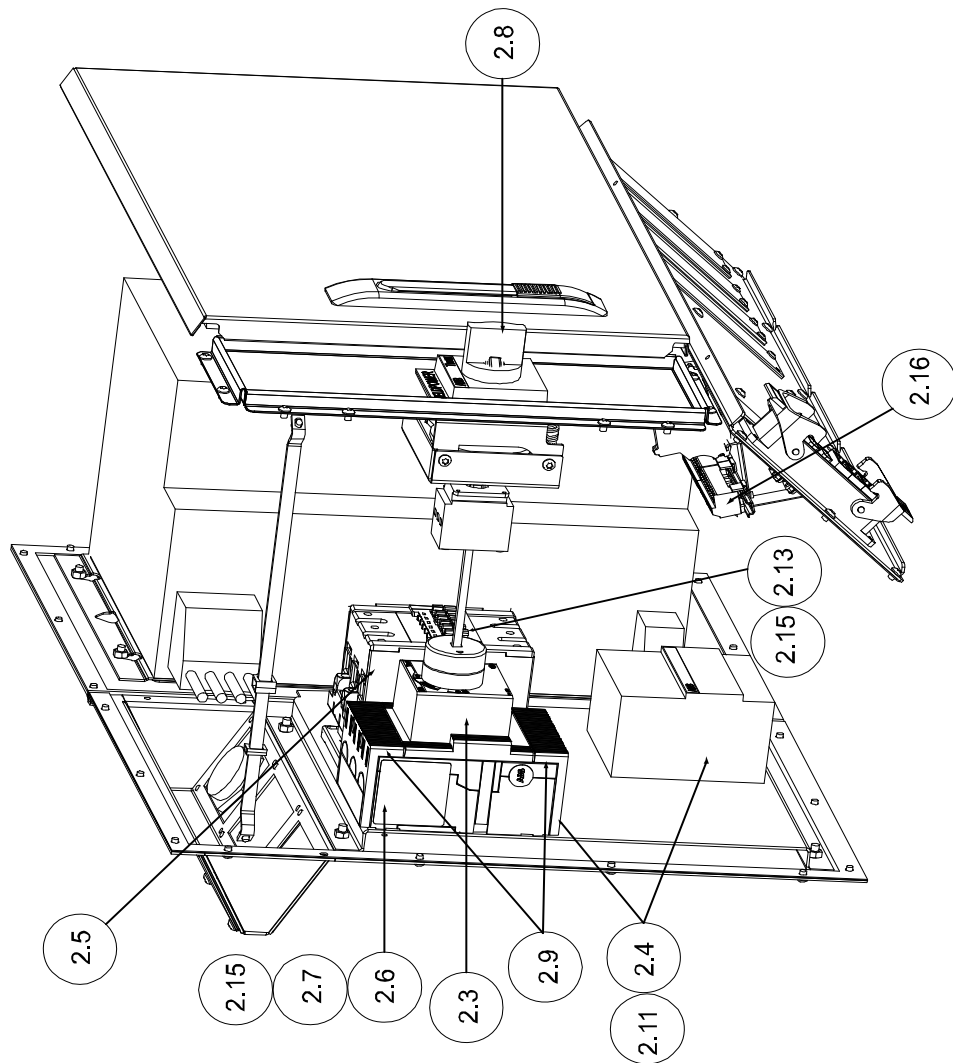

7 Spare parts

7.3.1. Spotwelding Cabinet IRC 5, 3HAC025036-001

Continued

Weld Timer

3HAC025070-001

| Item no. | Description | Spare part no. | Qty | Note |
|----------|-------------------------------|----------------|-----|---------------|
| 3 | Weld timer | | 1 | |
| 3.1 | Rear plate with gaskets | 3HAC024701-011 | 1 | |
| 3.1 | Rear plate | 3HAC029469-001 | 1 | Type Sb |
| 3.2 | Rear plate with gaskets | 3HAC024701-017 | 1 | |
| 3.3 | Weld timer Bosch AC | 3HAC025112-001 | 1 | PST 6100.630L |
| 3.3 | Weld Timer Bosch Compact | 3HAC030219-001 | 1 | Type Sb |
| 3.4 | Weld timer Bosch AC | 3HAC025112-002 | 1 | PST 6250.630L |
| 3.5 | Weld timer Bosch MFDC | 3HAC025113-001 | 1 | PSI 6100.630L |
| 3.8 | Harness weld timer Bosch AC | 3HAC025109-001 | 1 | |
| 3.8 | Harness Weld Timer Bosch | 3HAC029470-001 | 1 | Type Sb |
| 3.11 | Harness weld power Bosch AC | 3HAC025166-001 | 1 | |
| 3.12 | Harness weld power Bosch MFDC | 3HAC025167-001 | 1 | |
| 3.15 | Harness Bosch KSR | 3HAC025221-001 | 1 | |
| 3.15 | Harness EPV | 3HAC029488-001 | 1 | Type Sb |
| 3.16 | Harness Contactor, Bosch | 3HAC025222-001 | 1 | |

Weld Timer Illustration (figure shows Type S)

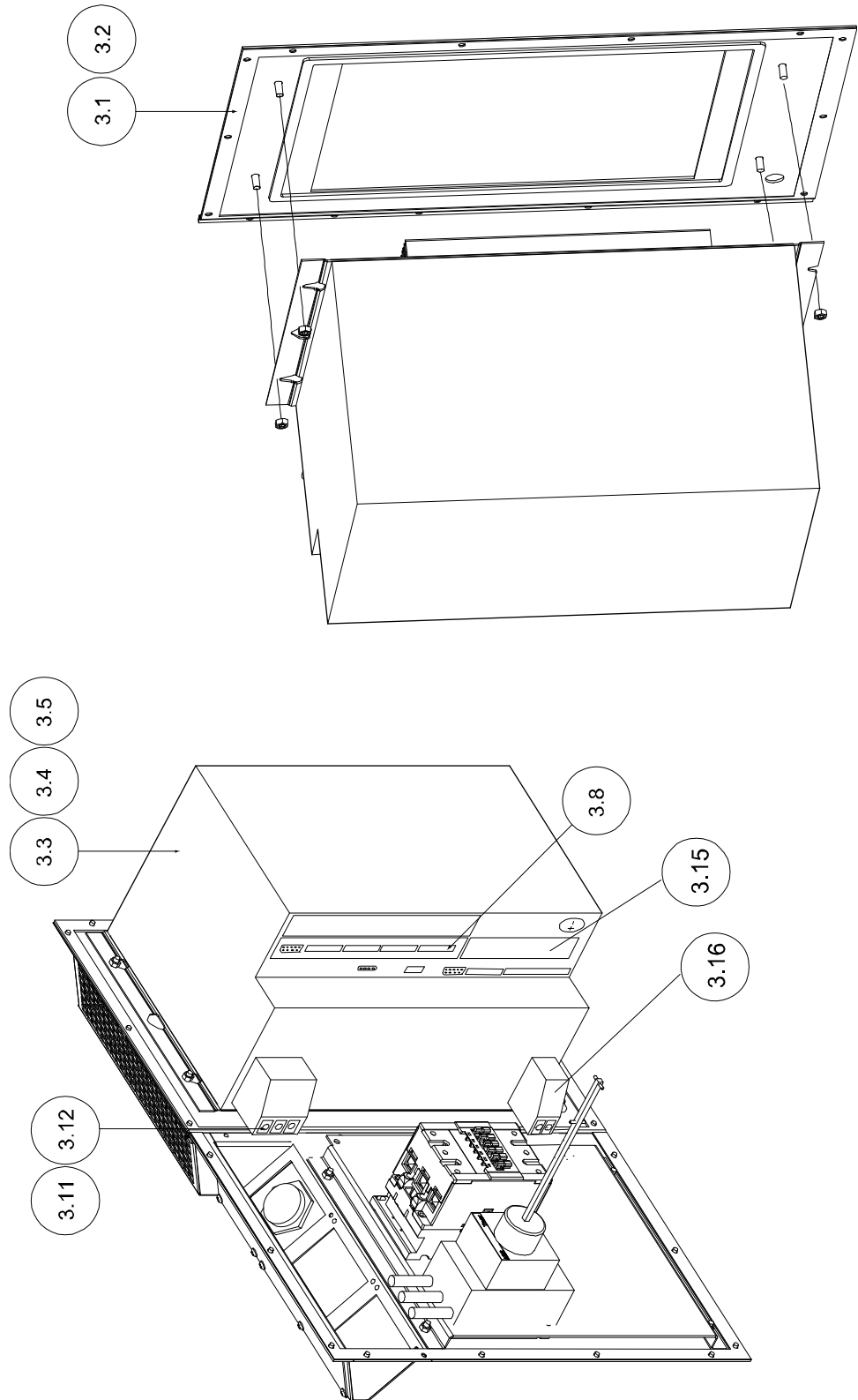

en0500001895

7 Spare parts

7.3.1. Spotwelding Cabinet IRC 5, 3HAC025036-001

Continued

Harness connector plate

3HAC025071-001

| Item no. | Description | Spare part no. | Qty | Note |
|----------|--------------------------------|----------------|-----|---|
| 4 | Harness connector plate | | | |
| 4.1 | Customer plate, with gasket | 3HAC024701-009 | 1 | Type S |
| 4.2 | Harness XP113 CP/CS/CBUS | 3HAC025133-001 | 1 | Type S |
| 4.3 | Harness RS232/485 | 3HAC027117-001 | 1 | Type S |
| 4.4 | Harness, Split box | 3HAC025106-001 | 1 | Fitting position shown in figure. Type S |
| 4.5 | Solid state relay | 3HAC026204-003 | 1 | Type S |
| 4.6 | End clamp | 3HAB7983-1 | 2 | PA 6.6 Type S and Type Sb |
| 4.7 | Feed-through-terminal | 9ACA11-5 | 4 | WDU 4 Type S and Type Sb |
| 4.8 | Fuse terminal | 9ACA15-1 | 4 | WSI 6 Type S and Type Sb |
| 4.9 | Fuse-link time lag | 5672817-17 | 1 | 2A Type S and Type Sb |
| 4.10 | Bridge 4-pole | 3HAC3986-5 | 1 | WQW 4/4 Type S and Type Sb |
| 4.11 | End cover | 9ACA48-5 | 1 | WAP 2,5-10 Type S and Type Sb |
| 4.12 | Terminal marking | 9ACA50-222 | 1 | DEK 6 FWZ 1-10 Type S and Type Sb |
| 4.13 | Connection block bracket | 3HAC024675-058 | 1 | Type S |
| 4.14 | Cover plate with gasket | 3HAB6797-3 | 1 | Type S and Type Sb |
| 4.37 | Cable grommet | 3HAC029637-001 | 1 | Type Sb |

© Copyright 2006-2010 ABB. All rights reserved.

Continues on next page

Harness connector plate illustration (figure shows Type S)

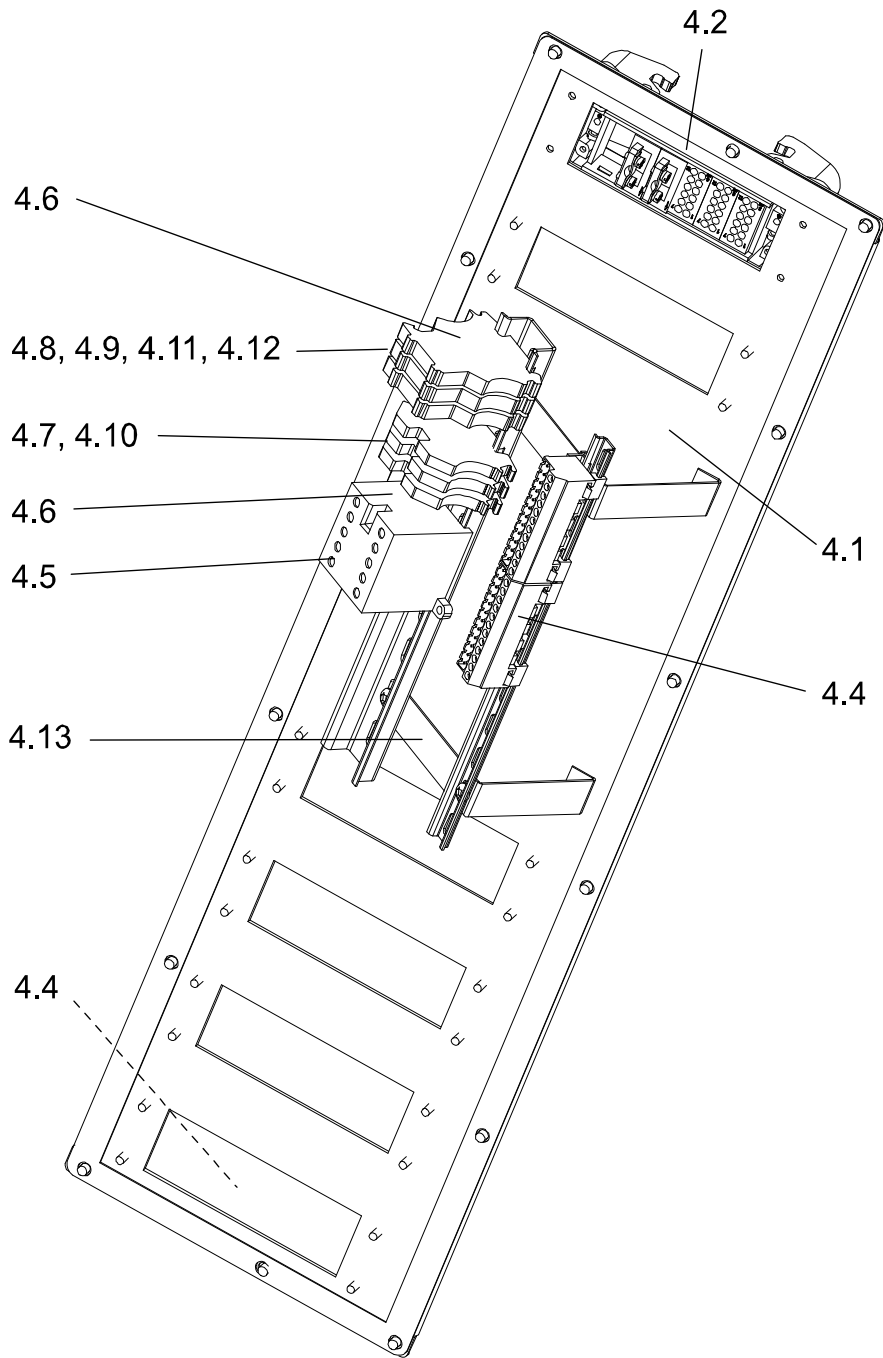

© Copyright 2006-2010 ABB. All rights reserved.

en0500001897

Continues on next page

7 Spare parts

7.3.1. Spotwelding Cabinet IRC 5, 3HAC025036-001

Continued

Accessories

3HAC025072-001

| Item no. | Description | Spare part no. | Qty | Note |
|----------|------------------------|----------------|-----|--------------------|
| 5 | Accessories | | | |
| 5.1 | Fan casing assembly | 3HAC024701-015 | 1 | Type S and Type Sb |
| 5.2 | Fan with receptacle | 3HAC029105-001 | 1 | Type S and Type Sb |
| 5.3 | Fan holder | 3HAC023860-001 | 1 | Type S and Type Sb |
| 5.4 | Harness weld timer fan | 3HAC025121-001 | 1 | Type S and Type Sb |

Accessories Illustration (figure shows Type S)

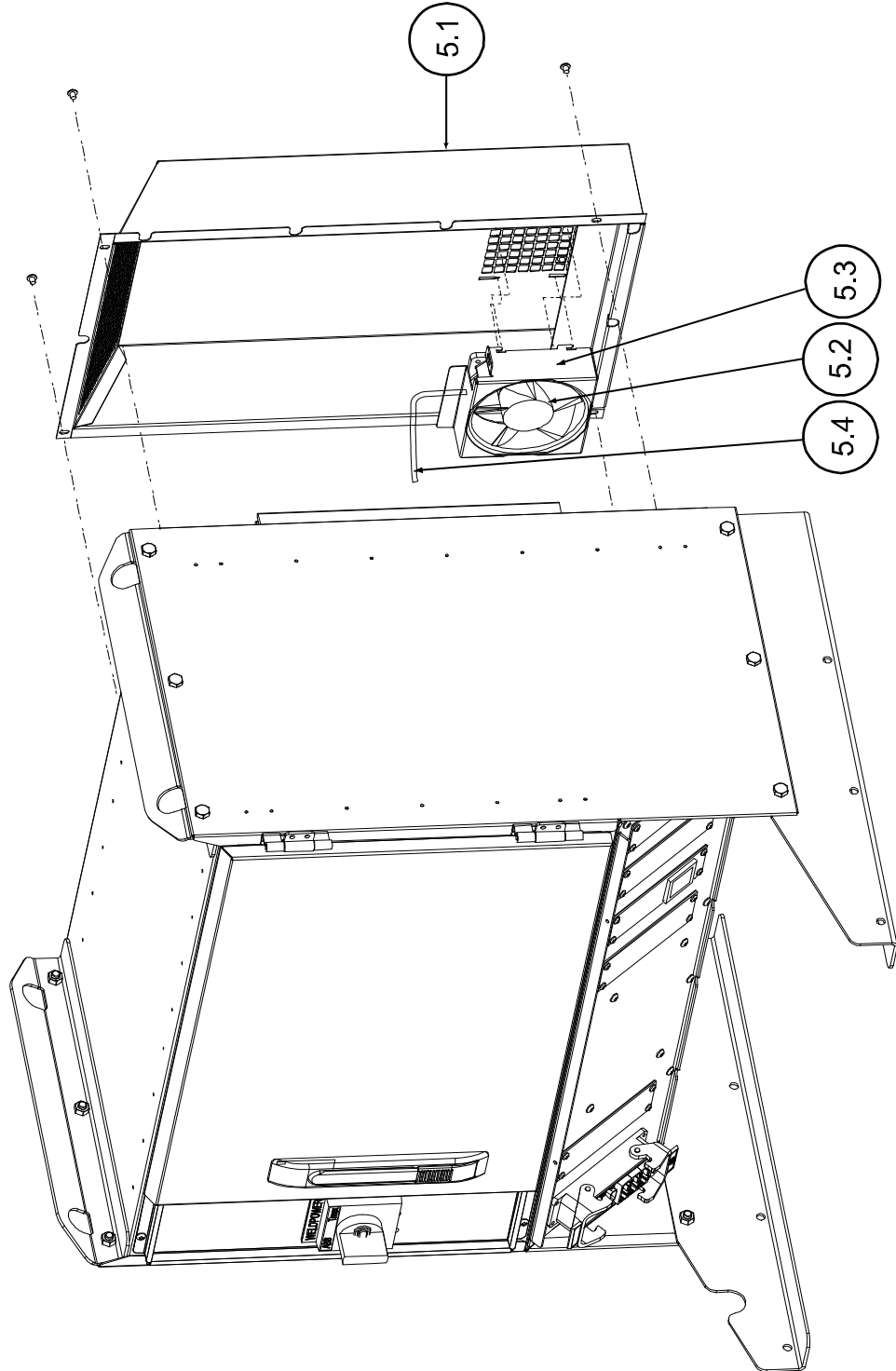

7 Spare parts

7.3.1. Spotwelding Cabinet IRC 5, 3HAC025036-001

Continued

Supplementary set

3HAC025073-001

| Item no. | Description | Spare part no. | Qty | Note |
|----------|-------------------|----------------|-----|----------------------------|
| 6 | Supplementary set | | | |
| 6.101 | Fastite screw | 3HAC024936-001 | 88 | M5x9 Type S and Type Sb |

Assembly set I/O SWC

| Item no. | Description | Spare part no. | Qty. | Note |
|----------|----------------------|----------------|------|---------|
| 9 | Assembly set I/O SWC | | | |
| 9.2 | Mounting bracket | 3HAC023714-001 | 2 | Type Sb |

Accessories control system

3HAC023818-001

| Item no. | Description | Spare part no. | Qty | Note |
|----------|-------------------------------|----------------|-----|------|
| 1 | Accessories control system | | | |
| 1.768 | Harness XS113 CP/CS/CBUS | 3HAC025144-001 | 1 | |
| 1.768 | Harness power supply 230/115V | 3HAC025150-001 | 1 | |
| 1.809 | Switch cable Stat.gun | 3HAC025191-001 | 1 | |

© Copyright 2006-2010 ABB. All rights reserved.

8 Circuit diagram

8.1. About circuit diagrams

Overview

The circuit diagrams are not included in this manual but delivered as separate documents on the documentation DVD. See below for correct article numbers.

Controllers

| Product | Article numbers for circuit diagrams |
|-------------------------------|--------------------------------------|
| IRC5 with Drive System 04 | 3HAC024480-004 |
| IRC5 with Drive System 09 | 3HAC024480-005 |
| IRC5 Panel Mounted Controller | 3HAC026871-005 |
| IRC5 Compact | 3HAC031403-003 |
| Euromap | 3HAC024120-004 |

DressPack/SpotPack

| Product | Article numbers for circuit diagrams |
|----------------------|--------------------------------------|
| DressPack 6620 | 3HAC026136-001 |
| SpotPack 6620 | 3HAC026208-001 |
| DressPack 6640 | 3HAC026209-001 |
| SpotPack 6640 | 3HAC026208-001 |
| DressPack 6650S/7600 | 3HAC026209-001 |
| SpotPack 6650S/7600 | 3HAC026208-001 |

8 Circuit diagram

8.1. About circuit diagrams

Continued

B

brakes
 testing function 27

C

carbon dioxide extinguisher 25
 connection
 external safety devices 16

D

danger levels 34

E

emergency stop
 definition 32
 devices 33
 enabling device 29

F

fire extinguishing 25

H

holding brakes 41
 hold-to-run 29

L

labels
 manipulator 36
 lifting equipment 256

M

manipulator
 labels 36
 symbols 36

P

protection standards 250

R

responsibility and validity 16

S

safety
 brake testing 27
 emergency stop 32
 fence dimensions 24
 fire extinguishing 25
 FlexPendant 29
 manipulator system 16
 moving manipulators 40
 reduced speed function 28
 release manipulator arm 26
 service 16
 signal lamp 31
 signals 34
 signals in manual 34
 symbols 34
 symbols on manipulator 36
 working range 30
 safety risk
 electric parts 23
 hot parts 19

hydraulic system 21
 installation 17
 operational disturbance 22
 pneumatic system 21
 tools 20
 voltage 23

safety risks
 service work 17
 work pieces 20

safety signals
 in manual 34
 safety standards 250
 signal lamp 31

signals
 safety 34
 standards
 ANSI 251
 CAN 251
 EN 250
 EN IEC 250
 EN ISO 250
 protection 250
 safety 250

symbols
 safety 34

T

testing
 brakes 27

V

validity and responsibility 16

Contact us

ABB AB

Discrete Automation and Motion

Robotics

S-721 68 VÄSTERÅS

SWEDEN

Telephone +46 (0) 21 344 400

3HAC027309-001 Rev D, en